

GB Forced draught gas burners

Modulating operation

CODE	MODEL	TYPE
20085848	RS 300/EV C01 TL	85848X
20073290	RS 400/EV C01 TL	73290X
20090668	RS 400/EV C01 TL	90668X



Translation of the original instructions

1	Declarations	3
2	Information and general warnings	4
2.1	Information about the instruction manual	4
2.1.1	Introduction	4
2.1.2	General dangers	4
2.1.3	Other symbols	4
2.1.4	Delivery of the system and the instruction manual	5
2.2	Guarantee and responsibility	5
3	Safety and prevention	6
3.1	Introduction	6
3.2	Personnel training	6
4	Technical description of the burner	7
4.1	Burner designation	7
4.2	Models available	7
4.3	Technical data	8
4.4	Electrical data	8
4.5	Burner categories - Countries of destination	9
4.6	Maximum dimensions	9
4.7	Firing rates	10
4.8	Test boiler	11
4.9	Burner equipment	11
4.10	Burner description	12
4.11	Electrical panel description	13
4.12	Control box for the air/fuel ratio (LMV52...)	14
4.13	Servomotor (SQM48.4...)	16
5	Installation	17
5.1	Notes on safety for the installation	17
5.2	Handling	17
5.3	Preliminary checks	17
5.4	Operating position	18
5.5	Removing the shutter lockout screws	18
5.6	Preparing the boiler	18
5.6.1	Boring the boiler plate	18
5.6.2	Blast tube length	18
5.7	Securing the burner to the boiler	19
5.8	Access to head internal part	19
5.9	Probe-electrode position	19
5.10	Combustion head adjustment	20
5.11	Gas feeding	21
5.11.1	Gas feeding line	21
5.11.2	Gas train	22
5.11.3	Gas train installation	22
5.11.4	Gas pressure	23
5.12	Electrical wiring	24
5.12.1	Supply cables and external connections passage	24
6	Start-up, calibration and operation of the burner	25
6.1	Notes on safety for the first start-up	25
6.2	Adjustments prior to ignition	25
6.3	Burner start-up	25
6.4	Burner ignition	25
6.5	Combustion air adjustment	26

6.5.1	Air adjustment for maximum output	26
6.5.2	Air/fuel adjustment and output modulation system	26
6.6	Pressure switch adjustment	27
6.6.1	Air pressure switch - check CO.....	27
6.6.2	Maximum gas pressure switch.....	27
6.6.3	Minimum gas pressure switch.....	27
6.6.4	PVP pressure switch kit	27
7	Maintenance	28
7.1	Notes on safety for the maintenance	28
7.2	Maintenance programme	28
7.2.1	Maintenance frequency.....	28
7.2.2	Checking and cleaning.....	28
7.3	Opening the burner	29
7.4	Closing the burner.....	29
8	Faults - Possible causes - Solutions.....	30
A	Appendix - Accessories	31
B	Appendix - Electrical panel layout.....	33

1 Declarations

Declaration of conformity in accordance with ISO / IEC 17050-1

Manufacturer: RIELLO S.p.A.
 Address: Via Pilade Riello, 7
 37045 Legnago (VR)
 Product: Forced draught gas burners
 Model: RS 300/EV C01 TL
 RS 400/EV C01 TL

These products are in compliance with the following Technical Standards:

EN 676

EN 12100

and according to the European Directives:

MD	2006/42/EC	Machine Directive
LVD	2006/95/EC	Low Voltage Directive
EMC	2004/108/EC	Electromagnetic Compatibility

The quality is guaranteed by a quality and management system certified in accordance with UNI EN ISO 9001.

Legnago, 10.10.2013

Operating Manager
 RIELLO S.p.A. - Burners Department
 Ing. G. Conticini

Research and Development Director
 RIELLO S.p.A. - Burners Department
 Ing. R. Cattaneo



2 Information and general warnings

2.1 Information about the instruction manual

2.1.1 Introduction

The instruction manual supplied with the burner:

- is an integral and essential part of the product and must not be separated from it; it must therefore be kept carefully for any necessary consultation and must accompany the burner even if it is transferred to another owner or user, or to another system. If the manual is lost or damaged, another copy must be requested from the Technical Assistance Service of the area;
- is designed for use by qualified personnel;
- offers important indications and instructions relating to the installation safety, start-up, use and maintenance of the burner.

Symbols used in the manual

In some parts of the manual you will see triangular DANGER signs. Pay great attention to these, as they indicate a situation of potential danger.

2.1.2 General dangers

The **dangers** can be of **3 levels**, as indicated below.



Maximum danger level!
This symbol indicates operations which, if not carried out correctly, cause serious injury, death or long-term health risks.



This symbol indicates operations which, if not carried out correctly, may cause serious injury, death or long-term health risks.



This symbol indicates operations which, if not carried out correctly, may cause damage to the machine and/or injury to people.

2.1.3 Other symbols



DANGER: LIVE COMPONENTS
This symbol indicates operations which, if not carried out correctly, lead to electric shocks with lethal consequences.



DANGER: FLAMMABLE MATERIAL
This symbol indicates the presence of flammable materials.



DANGER: BURNING
This symbol indicates the risks of burns due to high temperatures.



DANGER: CRUSHING OF LIMBS
This symbol indicates the presence of moving parts: danger of crushing of limbs.



WARNING: MOVING PARTS
This symbol indicates that you must keep limbs away from moving mechanical parts; danger of crushing.



DANGER: EXPLOSION
This symbol signals places where an explosive atmosphere is present. An explosive atmosphere is defined as a mixture of dangerous substances with air, under atmospheric conditions, in the form of gases, vapours, mist or dust in which, after ignition has occurred, combustion spreads to the entire unburned mixture.



PERSONAL PROTECTION EQUIPMENT
These symbols indicate the equipment that must be worn and kept by the operator for protection against threats against safety and/or health while at work.



MOUNT CASING
This symbol indicates that it is mandatory to mount casing again after maintenance, cleaning or checks.



ENVIRONMENTAL PROTECTION
This symbol gives indications for the use of the machine with respect for the environment.



IMPORTANT INFORMATION
This symbol indicates important information that you must bear in mind.

- This symbol indicates a list.

Abbreviations used

Ch.	Chapter
Fig.	Figure
Page	Page
Sec.	Section
Tab.	Table

2.1.4 Delivery of the system and the instruction manual

When the system is delivered, it is important that:

- the instruction manual is delivered to the user by the system manufacturer, with the recommendation to keep it in the room where the heat generator is to be installed.
- The instruction manual shows:
 - the serial number of the burner;

.....

- the address and telephone number of the nearest Assistance Centre;

.....

- The system supplier must carefully inform the user about:
 - the use of the system;
 - any further tests that may be required before activating the system;
 - maintenance, and the need to have the system checked at least once a year by a representative of the manufacturer or another specialised technician.
 To ensure a periodic check, the manufacturer recommends the drawing up of a Maintenance Contract.

2.2 Guarantee and responsibility

The manufacturer guarantees its new products from the date of installation, in accordance with the regulations in force and/or the sales contract. At the moment of the first start-up, check that the burner is integral and complete.



WARNING

Failure to observe the information given in this manual, operating negligence, incorrect installation and carrying out of non authorised modifications will result in the annulment by the manufacturer of the guarantee that it supplies with the burner.

In particular, the rights to the guarantee and the responsibility will no longer be valid, in the event of damage to things or injury to people, if such damage/injury was due to any of the following causes:

- incorrect installation, start-up, use and maintenance of the burner;
- improper, incorrect or unreasonable use of the burner;
- intervention of unqualified personnel;
- carrying out of unauthorised modifications on the equipment;
- use of the burner with safety devices that are faulty, incorrectly applied and/or not working;
- installation of untested supplementary components on the burner;
- powering of the burner with unsuitable fuels;
- faults in the fuel supply system;
- continuation of use of the burner when a fault has occurred;
- repairs and/or overhauls incorrectly carried out;
- modification of the combustion chamber with inserts that prevent the regular development of the structurally established flame;
- insufficient and inappropriate surveillance and care of those burner components most likely to be subject to wear and tear;
- use of non-original components, including spare parts, kits, accessories and optional;
- force majeure.

The manufacturer furthermore declines any and every responsibility for the failure to observe the contents of this manual.

3 Safety and prevention

3.1 Introduction

The burners have been designed and built in compliance with current regulations and directives, applying the known technical rules of safety and envisaging all the potential danger situations.

It is necessary, however, to bear in mind that the imprudent and clumsy use of the equipment may lead to situations of death risk for the user or third parties, as well as the damaging of the burner or other items. Inattention, thoughtlessness and excessive confidence often cause accidents; the same applies to tiredness and sleepiness.

It is a good idea to remember the following:

- The burner must only be used as expressly described. Any other use should be considered improper and therefore dangerous.

In particular:

it can be applied to boilers operating with water, steam, diathermic oil, and to other uses expressly foreseen by the manufacturer;

the type and pressure of the fuel, the voltage and frequency of the electrical power supply, the minimum and maximum deliveries for which the burner has been regulated, the pressurisation of the combustion chamber, the dimensions of the combustion chamber and the room temperature must all be within the values indicated in the instruction manual.

- Modification of the burner to alter its performance and destinations is not allowed.
- The burner must be used in exemplary technical safety conditions. Any disturbances that could compromise safety must be quickly eliminated.
- Opening or tampering with the burner components is not allowed, apart from the parts requiring maintenance.
- Only those parts envisaged by the manufacturer can be replaced.



The manufacturer guarantees safety and proper functioning only if all burner components are intact and positioned correctly.

3.2 Personnel training

The user is the person, body or company that has acquired the machine and intends to use it for the specific purpose. He is responsible for the machine and for the training of the people working around it.

The user:

- undertakes to entrust the machine exclusively to suitably trained and qualified personnel;
- undertakes to inform his personnel in a suitable way about the application and observance of the safety instructions. With that aim, he undertakes to ensure that everyone knows the use and safety instructions for his own duties.
- Personnel must observe all the danger and caution indications shown on the machine.
- Personnel must not carry out, on their own initiative, operations or interventions that are not within their province.
- Personnel must inform their superiors of every problem or dangerous situation that may arise.
- The assembly of parts of other makes, or any modifications, can alter the characteristics of the machine and hence compromise operating safety. The manufacturer therefore declines any and every responsibility for any damage that may be caused by the use of non-original parts.

In addition:



- must take all the measures necessary to prevent unauthorised people gaining access to the machine;
- the user must inform the manufacturer if faults or malfunctioning of the accident prevention systems are noticed, along with any presumed danger situation;
- personnel must always use the personal protective equipment envisaged by legislation and follow the indications given in this manual.

4 Technical description of the burner

4.1 Burner designation

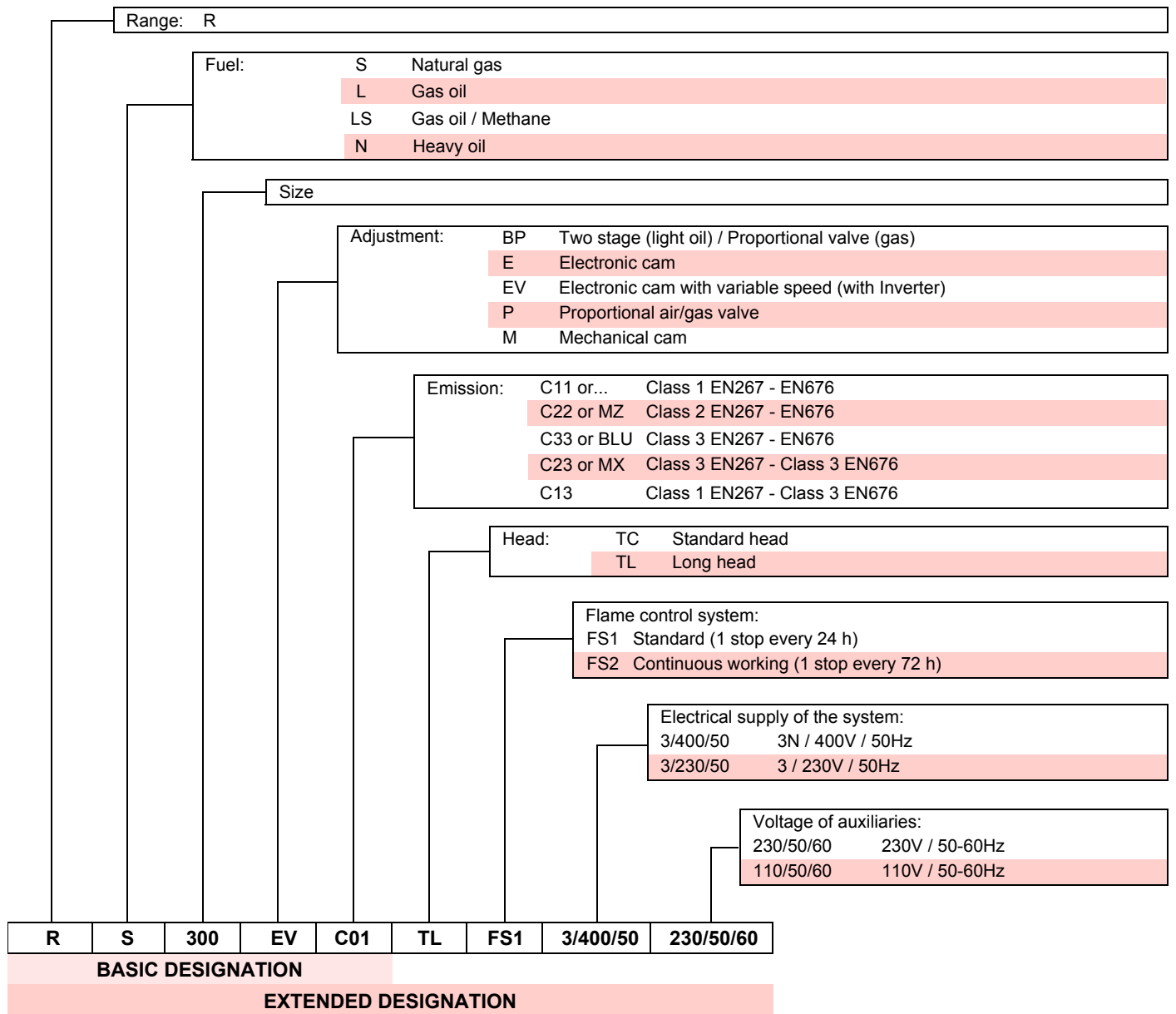

4.2 Models available

Designation	Voltage	Start-up	Code
RS 300/EV C01 TL	3/400/50	Inverter	20085848
RS 400/EV C01 TL	3/400/50	Inverter	20073290
RS 400/EV C01 TL	3/400/50	Inverter	20090668

Tab. A

4.3 Technical data

Model			RS 300/EV C01 TL	RS 400/EV C01 TL
Type			85848X	73290X - 90668X
Power (1) Delivery (1)	min - max	kW	500/1350 ÷ 3800	800/1840÷4550
Fuels			Natural gas: G20 (methane gas) - G21 - G22 - G23 - G25	
Gas pressure at max. output (2) - Gas: G20/G25		mbar	23.3/32.7	34.3/40.2
Operation			Continuous / Intermittent	
Standard applications			Boilers: water, steam, diathermic oil	
Ambient temperature		°C	0 - 50	
Air temperature combustion		°C max	60	
Noise levels (3)				
Sound pressure		dB(A)	82	85
Sound power			93	96
Burner weight		Kg	230	240

Tab. B

- (1) Reference conditions: Ambient temperature 20°C - Gas temperature 15°C - Barometric pressure 1013 mbar - Altitude 0 m a.s.l.
 (2) Pressure at the test point of the pressure switch (20)(Fig. 4) with zero pressure in the combustion chamber and at maximum burner output.
 (3) Sound pressure measured in manufacturer's combustion laboratory, with burner operating on test boiler and at maximum rated output. The sound power is evaluated, in line with the regulations, on a spherical surface centred on the burner and with a radius of 1 metre.

4.4 Electrical data

Motor IE2

Model			RS 300/EV C01 TL	RS 400/EV C01 TL
Main electrical supply			3N ~ 400V +/-10% 50 Hz	
Fan motor	rpm		2900	2900
	V		230/400	400/690
	kW		4.5	7.5
	A		15 - 8.7	13.8 - 8
Ignition transformer		V1 - V2 I1 - I2	230V - 1 x 8 kV 1A - 20mA	
Absorbed electrical power		kW max	5.9	9.2
Protection level			IP 54	

Tab. C

4.5 Burner categories - Countries of destination

Gas category	Destination country
I ₂ H	SE - FI - AT - GR - DK - ES - GB - IT - IE - PT - IS - CH - NO
I ₂ ELL	DE
I ₂ L	NL
I ₂ Er	FR
I ₂ E(R)B	BE
I ₂ E	LU - PL

Tab. D

4.6 Maximum dimensions

The maximum dimensions of the burner are given in Fig. 1. Bear in mind that inspection of the combustion head requires the burner to be opened and the rear part turned on the hinge.

The maximum dimensions of the open burner are indicated by the L and R positions.

The I position is reference for the refractory thickness of the boiler door.

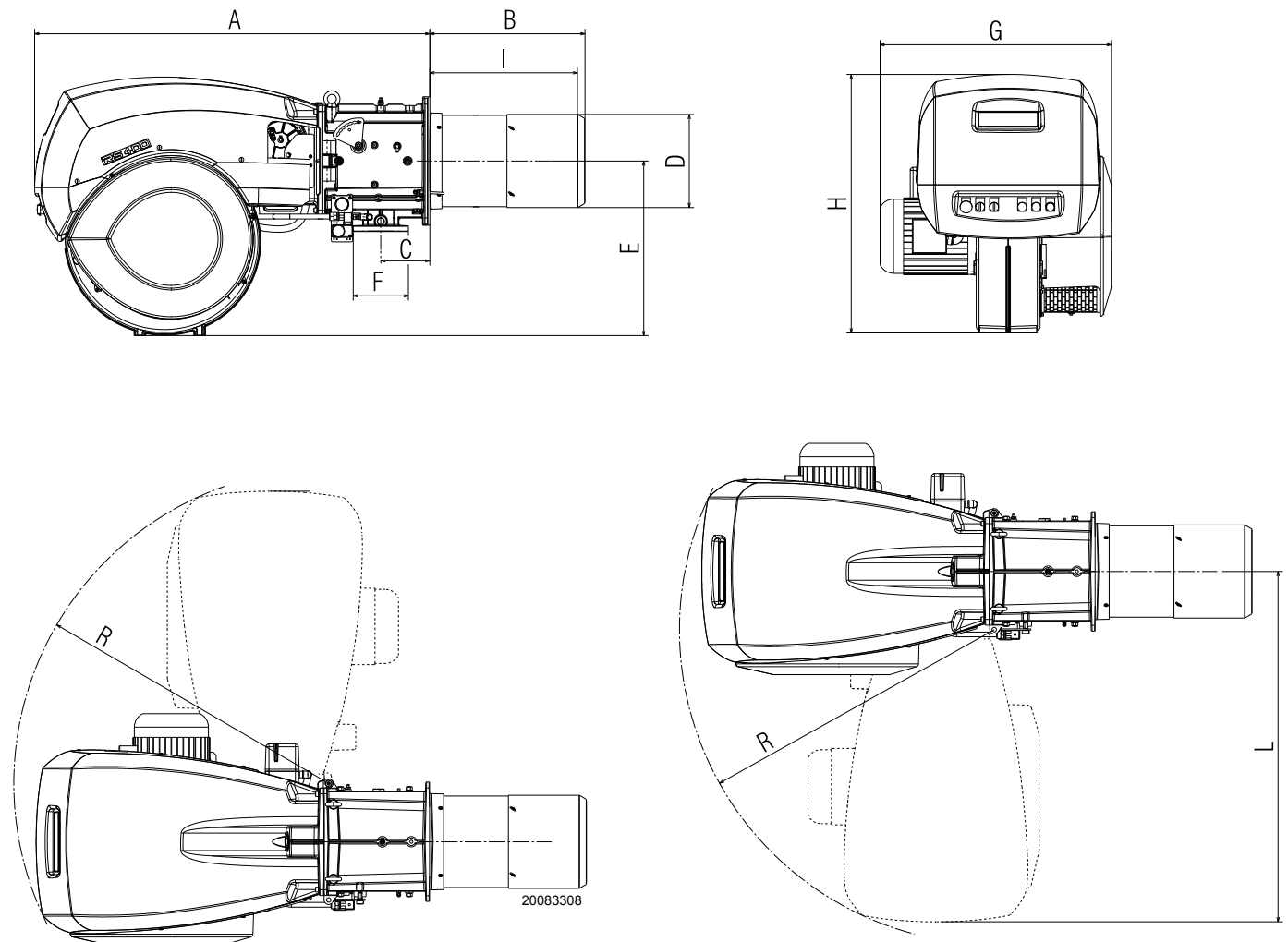

Fig. 1

mm	A	B	C	D	E	F	G	H	I	L	R
RS 300/EV C01 TL	1325	521	164	313	588	DN65	744	867	495	1175	1055
RS 400/EV C01 TL	1325	521	164	313	588	DN65	775	867	495	1175	1055

Tab. E

4.7 Firing rates

The **MAXIMUM OUTPUT** is chosen from within the diagram area (Fig. 2).

The **MINIMUM OUTPUT** must not be lower than the minimum limit of the diagram:

Model	kW
RS 300/EV C01 TL	500
RS 400/EV C01 TL	800



The firing rate value (Fig. 2) has been obtained considering an ambient temperature of 20 °C, an atmospheric pressure of 1013 mbar (approx. 0 m a.s.l.), and with the combustion head adjusted as shown on page 20.

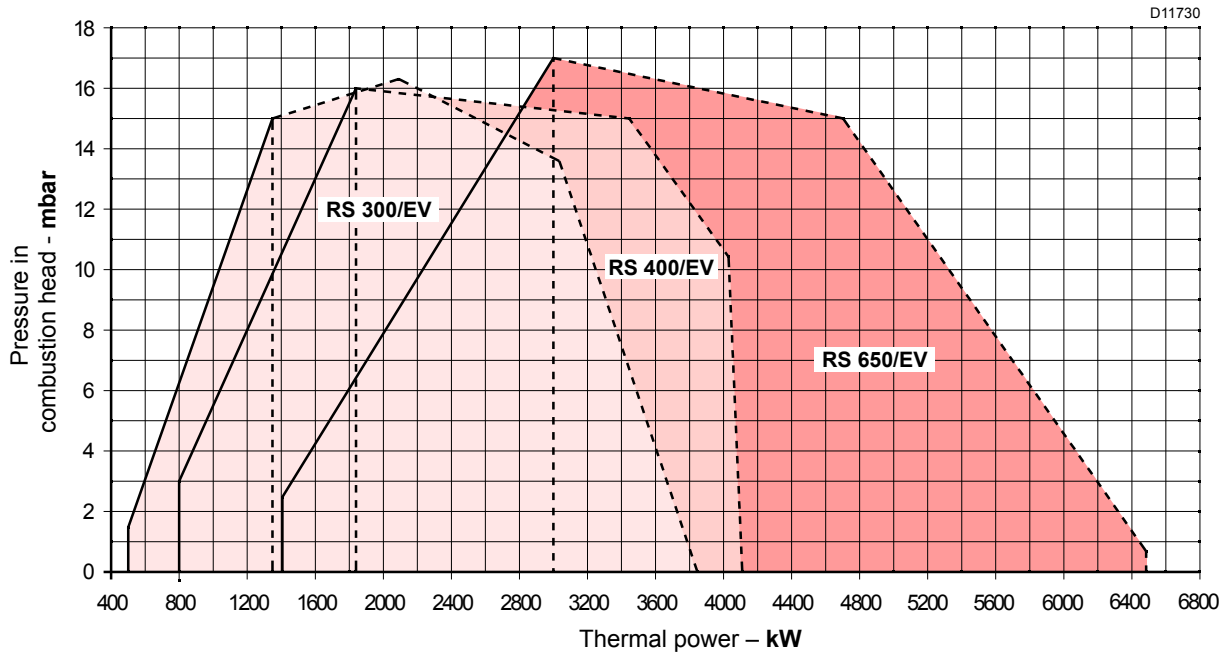

Fig. 2

4.8 Test boiler

The burner/boiler combination does not pose any problems if the boiler is EC approved and its combustion chamber dimensions are similar to those indicated in the diagram (Fig. 3).

If the burner must be combined with a boiler that has not been EC approved and/or its combustion chamber dimensions are clearly smaller than those indicated in the diagram, consult the manufacturer.

The firing rates were set in relation to special test boilers, according to EN 676 regulations.

In Fig. 3 you can see the diameter and length of the test combustion chamber.

Example:
Output 7000 kW - diameter 120 cm - length 6m

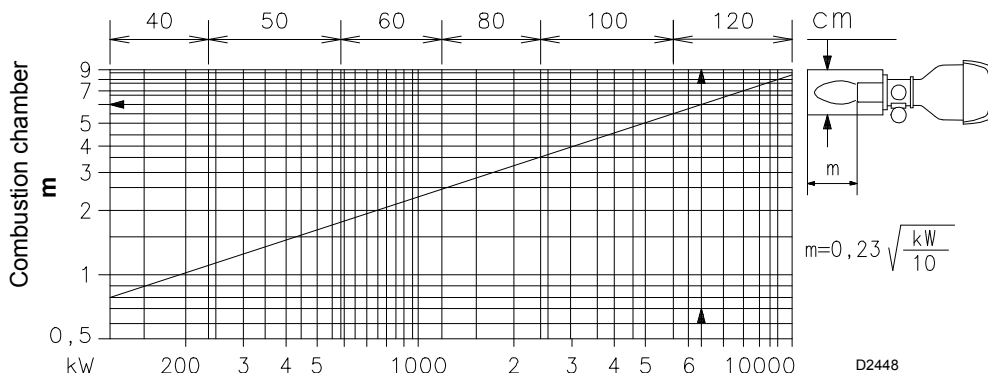

Fig. 3

4.9 Burner equipment

- Gasket for gas train adaptor No. 1
- Screws for fixing the gas train adaptor: M 16 x 70 No. 8
- Thermal insulation screen No. 1
- M 18 x 60 screws to secure the burner flange to the boiler No. 4
- Pressure switch (for leak detection control) No. 1
- Cable grommets kit for optional electrical wiring input No. 1
- Spacers (Fig. 16 on page 20) No. 2
- Instructions No. 1
- Spare parts list No. 1

4.10 Burner description

- 1 Lifting rings
- 2 Fan
- 3 Fan motor
- 4 Air damper servomotor
- 5 Combustion head gas pressure test point
- 6 Combustion head
- 7 Ignition electrode
- 8 Flame stability disk
- 9 Electrical panel casing
- 10 Gas butterfly valve servomotor
- 11 Fan air inlet
- 12 Pipe coupling
- 13 Gasket for boiler fixing
- 14 Gas butterfly valve
- 15 Shutter
- 16 Combustion head movement lever
- 17 Air damper movement gears
- 18 Air pressure switch
- 19 Combustion head air pressure test point
- 20 Maximum gas pressure switch with pressure test point
- 21 Flame sensor probe
- 22 Hinge for opening the burner
- 23 Pressure test point for air pressure switch “+”
- 24 Pressure test point for air pressure switch “-”
- 25 Rpm sensor
- 26 Gas input flange

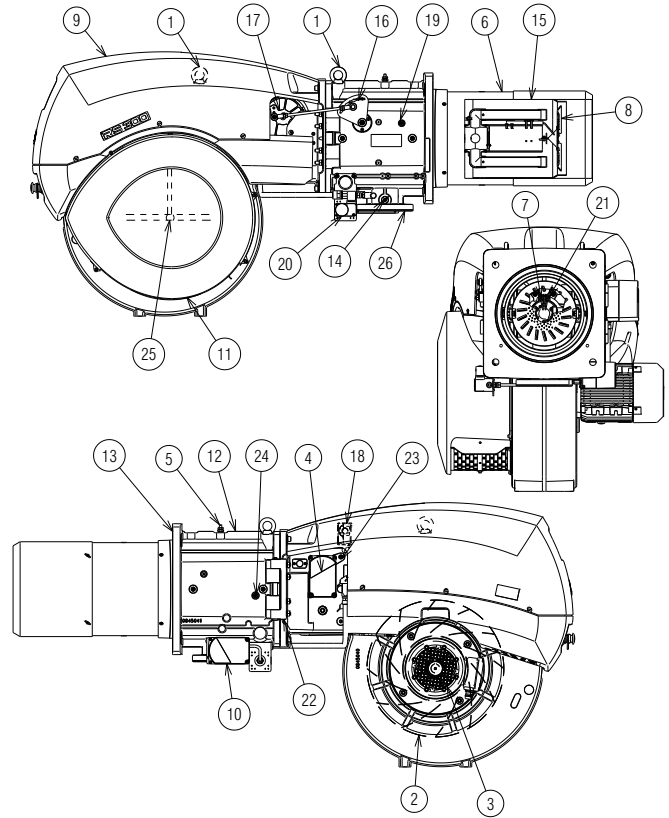

The burner can be opened to the right or to the left without links to the fuel supply side.
When the burner is closed, the hinge can be refitted on the opposite side.

20086355

Fig. 4

4.11 Electrical panel description

20077311

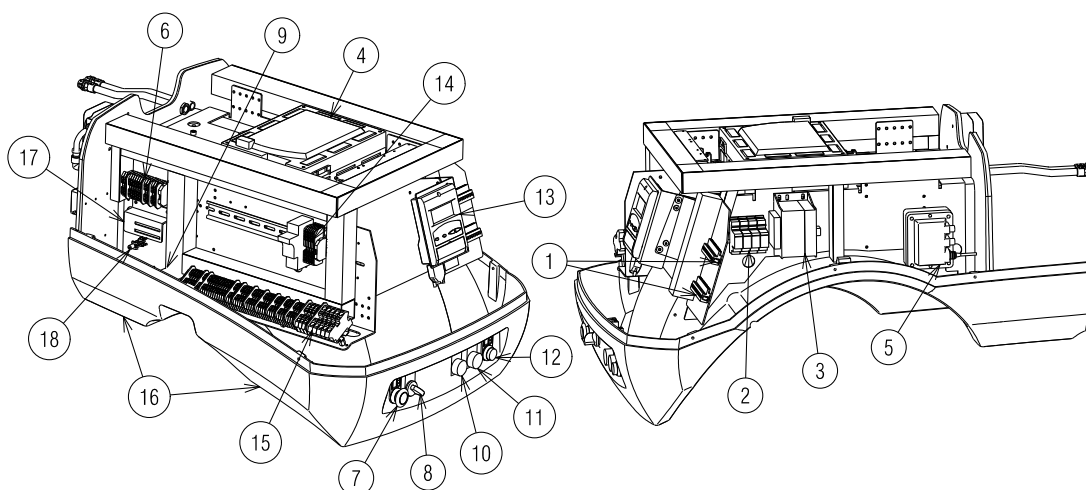

Fig. 5

- 1 O₂ kit plugs-sockets
- 2 Clean contacts output relay
- 3 Electronic cam transformer
- 4 Calibration device with electronic cam
- 5 Ignition transformer
- 6 O₂ sensor terminal board
- 7 Stop push-button
- 8 Off-automatic selector
- 9 Bracket for shielding and fixing shielded cables of the regulating probes
- 10 Warning lamp for voltage of auxiliaries
- 11 Fan motor lock-out warning lamp
- 12 Burner lockout warning lamp and reset switch
- 13 AZL display
- 14 Auxiliary terminal board
- 15 Main terminal supply board and Inverter kit
- 16 Supply cables, external connections and kits
- 17 Bracket for shielding and Kit O₂ shielded cables
- 18 Clamp for shielded cables:



WARNING

do not overtighten, as it only ensures the continuity of the cable shielding.

Two types of burner failure may occur:

- **Flame control lockout:** if the pilot light 12)(Fig. 5) on the panel lights up, it indicates that the burner is in lockout. release by pressing the pushbutton 12)(Fig. 5).
- **Motor lockout:** refer to the Inverter manual.

The inverter kit and O₂ kit must be connected by the client/installing technician in accordance with the respective documentation (wiring diagrams) supplied with burner and the kits themselves.

4.12 Control box for the air/fuel ratio (LMV52...)

Warnings



To avoid accidents, material or environmental damage, observe the following instructions!

The LMV52 control box... is a safety device! Avoid opening or modifying it, or forcing its operation. Riello S.p.A. cannot assume any responsibility for damage resulting from unauthorised interventions!

Risk of explosion!

An incorrect configuration can provoke fuel overcharging, with the consequential risk of explosion! Operators must be aware that incorrect settings made on the AZL5... display and operating unit and incorrect settings of the fuel and / or air actuator positions can lead to dangerous burner operating conditions.

- All interventions (assembly and installation operations, assistance, etc.) must be carried out by qualified personnel.
- Before modifying the wiring in the LMV52 control box connection area, fully disconnect the system from the power supply (omnipolar separation). Check the system is not powered and cannot be accidentally reconnected. Failure to do this will lead to the risk of electrocution.
- Protection against electrocution from the LMV5... control box and all connected electric components is obtained with correct assembly.
- Before any intervention (assembly and installation operations, assistance, etc.), ensure the wiring is in order and that the parameters are correctly set, then make the safety checks.
- Falls and collisions can negatively affect the safety functions.
In this case, the control box must not be operated, even if it displays no evident damage.
- In programming mode, the position check of actuators and VSD (checking electronic fuel / air ratio control) is different from the check during automatic operation.
As for automatic operation, the actuators are guided together to the positions requested and, if an actuator does not reach the position requested, adjustments are made until the position is actually reached. However, in contrast to automatic operation, there are no time limits to these corrective actions.
The other actuators maintain their positions until all actuators have reached the positions currently required.
This is absolutely important to set the fuel / air ratio control system.
During the time the fuel / air ratio curves are being programmed, the person making the plant settings must continuously monitor the quality of the combustion process (e.g. by means of a flue gas analyser).
Also, if combustion levels are poor, or in the event of dangerous situations, the commissioning engineer must take appropriate action (e.g. switching off manually).

To ensure the safety and reliability of the LMV5... system, the following instructions must also be followed:

- avoid conditions that can favour the development of condensate and humidity. Otherwise, before switching on again, make sure that the entire control box is perfectly dry!

- Static charges must be avoided since they can damage the control box's electronic components when touched.



Fig. 6

Mechanical structure

The LMV5... control box is a system to check the burners, based on a microprocessor and equipped with components to adjust and monitor medium and large capacity forced draught burners. The base control box of the LMV5... system incorporates the following components:

- Burner control with gas valve proving system
- Electronic fuel / air ratio control with a maximum of 4 (LMV51...) or 6 (LMV52...) actuators
- Optional PID temperature / pressure controller (load controller)
- Optional VSD module Mechanical design

Installation notes

- Check the electric wiring inside the boiler complies with the national and local safety regulations.
- Do not confuse the powered conductors with the neutral ones.
- Make sure the cable grommets of the connected cables comply with the relevant standards (e.g. DIN EN 60730 and DIN EN 60 335).
- Ensure that spliced wires cannot get into contact with neighbouring terminals. Use adequate ferrules.
- Arrange the HV ignition cables separately, as far as possible from the control box and the other cables.
- The burner manufacturer must protect unused AC 230V terminals with dummy plugs (refer to sections Suppliers of other accessory items).
- When wiring the unit, make sure that AC 230V mains voltage cables are run strictly separate from extra low-voltage cables to avoid risks of electrical shock hazard.

Electrical connection of ionisation probe and flame detector

It is important for signal transmission to be almost totally free of any disturbances or loss:

- always separate the detector cables from the other cables:
 - Line capacitance reduces the magnitude of the flame signal.
 - Use a separate cable.

- Respect the allowed cable lengths.
- The ionisation probe is not protected against the risk of electrocution. When connected to the electricity supply, the ionisation probe must be protected against any accidental contact.
- **Position the ignition electrode and the ionisation probe so that the ignition spark cannot form an arc on the probe (risk of electric overcharge).**

Technical data

LMV52... base control box	Mains voltage	AC 230V -15% / +10%
	Mains frequency	50 / 60 Hz $\pm 6\%$
	Power absorption	< 30W (normal)
	Safety class	I, with components in compliance with II and III, according to DIN EN 60730-1
Load on 'input' terminals	F1 unit fuse (internal)	6.3 AT
	Primary perm. mains fuse (external)	Max. 16 AT
	Undervoltage	
	• Safety switch-off from operating position to mains voltage	< AC 186V
	• Restart when mains voltage picks up	> AC 188V
Load on 'output' terminals	Oil pump / magnetic clutch (nominal voltage) - (only for dual fuel or light oil burners)	
	• Nominal current	2A
	• Power factor	$\cos\phi > 0.4$
	Air pressure switch test valve (nominal voltage)	
	• Nominal current	0.5A
• Power factor	$\cos\phi > 0.4$	
Cable length	Total load on the contacts:	
	• Mains voltage	AC 230V -15 % / +10%
	• Total unit input current (safety circuit) load on contacts due to:	Max. 5 A
	- Fan motor contactor	
	- Ignition transformer	
	- Valve	
	- Oil pump / magnetic clutch (if present)	
	Single contact loading:	
	Fan motor contactor (nominal voltage)	
	• Nominal current	1A
	• Power factor	$\cos\phi > 0.4$
	Alarm output (nominal voltage)	
	• Nominal current	1A
	• Power factor	$\cos\phi > 0.4$
	Ignition transformer (nominal voltage)	
• Nominal current	2A	
• Power factor	$\cos\phi > 0.2$	
Fuel gas valve (nominal voltage)		
• Nominal current	2A	
• Power factor	$\cos\phi > 0.4$	
Fuel oil valve (nominal voltage) - (only for dual fuel or light oil burners)		
• Nominal current	1A	
• Power factor	$\cos\phi > 0.4$	
Environmental conditions	Main line	Max. 100 m (100 pF / m)
	Operation	DIN EN 60721-3-3
	Climatic conditions	Class 3K3
	Mechanical conditions	Class 3M3
	Temperature range	-20...+60°C
Humidity	< 95% RH	

4.13 Servomotor (SQM48.4....)

Warnings



To avoid accidents, material or environmental damage, observe the following instructions!

Avoid opening, modifying or forcing the actuators.

- All interventions (assembly and installation operations, assistance, etc.) must be carried out by qualified personnel.
- Before modifying the wiring in the SQM4... system connection area, fully disconnect the burner control device from the power supply (omnipolar separation).
- To avoid the risk of electrocution, protect the connection terminals in a suitable manner and correctly fix the cover.
- Check the wiring is in order.
- Falls and collisions can negatively affect the safety functions. In this case, the unit must not be operated, even if it displays no evident damage.

Assembly notes

- Check the relevant national safety standards are respected.
- The connection between the actuator command shaft and the control element must be rigid, without any mechanical play.
- To avoid an excessive load on the bearings due to rigid hubs, the use of compensation clutches without any mechanical play is recommended (e.g. metal bellows-type clutches).

Installation notes

- Arrange the H.V. ignition cables separately, as far as possible from the control box and the other cables.
- To avoid the risk of electrocution, make sure that the 230V AC section of the SQM4... unit is fully separated from the functional low-voltage section.
- The static torque is reduced when the electrical supply of the actuator is switched off.
- The housing cover may only be removed for short periods of time for wiring or when making the addressing. In similar cases, make sure that dust or dirt does not penetrate inside the actuator.
- The actuator comprises a PCB with ESD-sensitive components.
- The top side of the board carries a cover which affords protection against direct contact. This protective cover must not be removed! The underside side of the board must not be touched.



During the maintenance or replacement of the actuators, be careful not to invert the connectors.

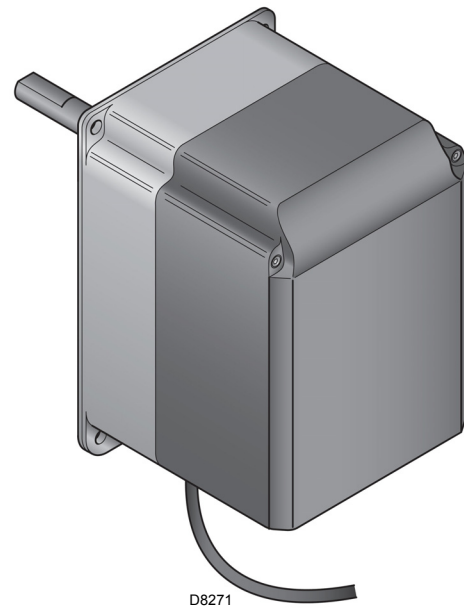

Fig. 7

Technical data

Operating voltage	AC 2 x 12 V via bus cable from the base unit or via a separate transformer
Safety class	extra low-voltage with safe isolation from mains voltage
Power consumption	26...34 VA
Degree of protection	to EN 60 529, IP 54, provided adequate cable entries are used
Cable connection	RAST3,5 connectors
Rotation direction	- Anticlockwise (standard) - Clockwise (inverted rotation)
Nominal torque (max)	20 Nm
Holding torque (max)	20 Nm
Running time (min.) for 90°	30 s.
Weight	approx. 1.6 kg
Environmental conditions:	
Operation	DIN EN 60 721-3-3
Climatic conditions	3K3 Class
Mechanical conditions	3M3 Class
Temperature range	-20...+60°C
Humidity	< 95% RH

5 Installation

5.1 Notes on safety for the installation

After carefully cleaning all around the area where the burner will be installed, and arranging the correct lighting of the environment, proceed with the installation operations.



All the installation, maintenance and disassembly operations must be carried out with the electricity supply disconnected.



The installation of the burner must be carried out by qualified personnel, as indicated in this manual and in compliance with the standards and regulations of the laws in force.



Combustion air inside the boiler must be free from hazardous mixes (e.g.: chloride, fluoride, halogen); if present, it is highly recommended to carry out cleaning and maintenance more frequently.

5.2 Handling

The burner packaging includes a wooden platform, it is therefore possible to move the burner (still packaged) with a transpallet truck or fork lift truck.



The handling operations for the burner can be highly dangerous if not carried out with the greatest attention: keep any unauthorised people at a distance; check the integrity and suitability of the available means of handling. Check also that the area in which you are working is empty and that there is an adequate escape area (i.e. a free, safe area to which you can quickly move if the burner should fall). When handling, keep the load at not more than 20-25 cm from the ground.



After positioning the burner near the installation point, correctly dispose of all residual packaging, separating the various types of material.



Before proceeding with the installation operations, carefully clean all around the area where the burner will be installed.

5.3 Preliminary checks

Checking the consignment



After removing all the packaging, check the integrity of the contents. In the event of doubt, do not use the burner; contact the supplier.



The packaging elements (wooden cage or cardboard box, nails, clips, plastic bags, etc.) must not be abandoned as they are potential sources of danger and pollution; they should be collected and disposed of in the appropriate places.

RBL	A	B	C
D	E		F
GAS: KAASU	<input checked="" type="checkbox"/>	G	H
GAZ: AERIO		G	H
I			RIELLO SpA 1-37045 Legnago (VR)
			CE

D10411

Fig. 8

Checking the characteristics of the burner

Check the identification label of the burner, showing:

- the model (A)(Fig. 8) and type of burner (B);
- the year of manufacture, in cryptographic form (C);
- the serial number (D);
- the data for electrical supply and the protection level (E);
- the absorbed electrical power (F);
- the types of gas used and the relative supply pressures (G);
- the data of the burner's minimum and maximum output possibilities (H) (see Firing rate)

Warning. The burner output must be within the boiler's firing rate;

- the category of the appliance/countries of destination (I).



A burner label, or any other component, that has been tampered with, removed or is missing, prevents the definite identification of the burner and makes any installation or maintenance work difficult.

5.4 Operating position



- The burner is designed to operate only in positions 1, 2, 3 and 4 (Fig. 9).
- Installation 1 is preferable, as it is the only one that allows the maintenance operations as described in this manual.
- Installations 2, 3 and 4 permit operation but make maintenance and inspection of the combustion head more difficult.



- Any other position could compromise the correct operation of the appliance.
- Installation 5 is prohibited for safety reasons.

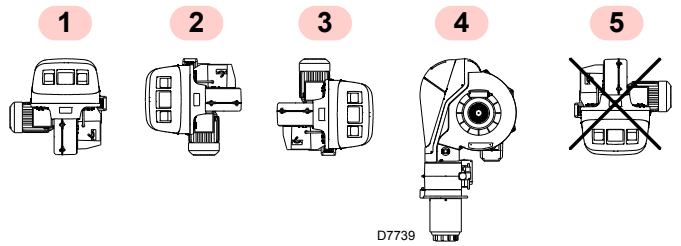

Fig. 9

5.5 Removing the shutter lockout screws



Remove the screws 1)-2) and nuts before fitting the burner onto the boiler (Fig. 10).

Replace with the screws 3) M12 x25 supplied as standard.

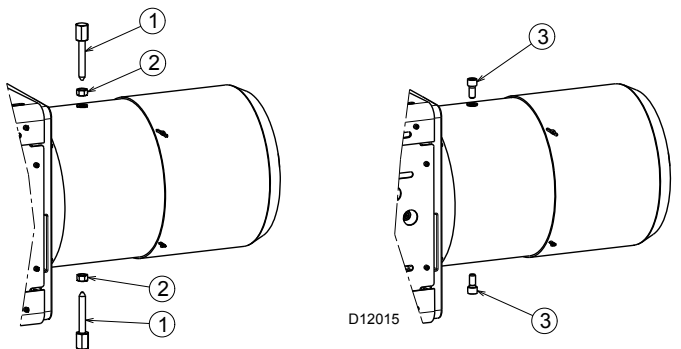

Fig. 10

5.6 Preparing the boiler

5.6.1 Boring the boiler plate

Pierce the closing plate of the combustion chamber, as in Fig. 11. The position of the threaded holes can be marked using the thermal insulation screen supplied with the burner.

5.6.2 Blast tube length

The length of the blast tube must be selected according to the indications provided by the manufacturer of the boiler, and in any case it must be greater than the thickness of the boiler door complete with its fettling.

For boilers with front flue passes 1)(Fig. 12) or flame inversion chamber, a protection in refractory material 5) must be inserted between the boiler fettling 2) and the blast tube 4).

This protective fettling must not compromise the extraction of the blast tube.

For boilers with a water-cooled front piece, a refractory lining 2)-5)(Fig. 12) is not necessary, unless expressly requested by the boiler manufacturer.

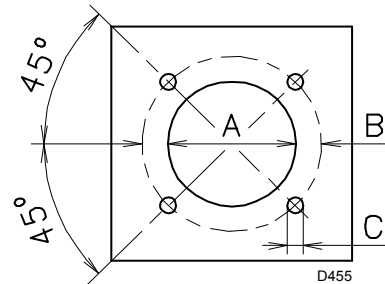

Fig. 11

mm	A	B	C
RS 300/EV C01 TL	350	452	M18
RS 400/EV C01 TL	350	452	M18

Tab. F

5.7 Securing the burner to the boiler



Prepare a suitable lifting system using the rings 3)(Fig. 12), after removing the fixing screws 7) of the casing 8).

- Fit the heat insulation supplied onto the blast tube (4)(Fig. 12).
- Fit the entire burner onto the boiler hole prepared previously (Fig. 11), and fasten with the screws supplied.



The seal between burner and boiler must be airtight.

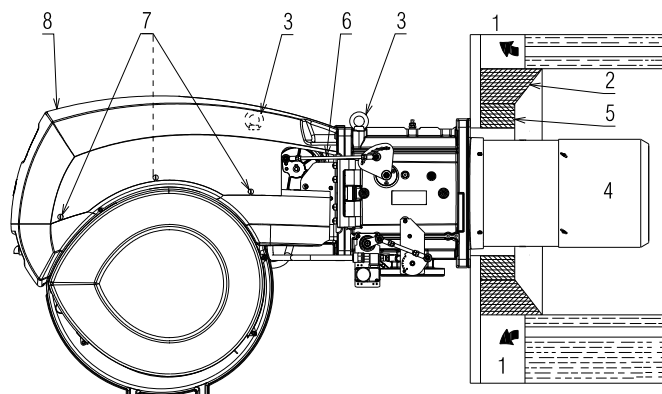

20073876
Fig. 12

5.8 Access to head internal part

- After you have uncoupled the head movement lever tie-rod 1) and removed the 4 fixing screws 2), open the burner on the hinge (Fig. 13).
- Unhook the probe cables and electrode 3).
- Tighten the underneath part of the elbow 4) until it is released from its housing.
- Remove the internal part of the head 5).

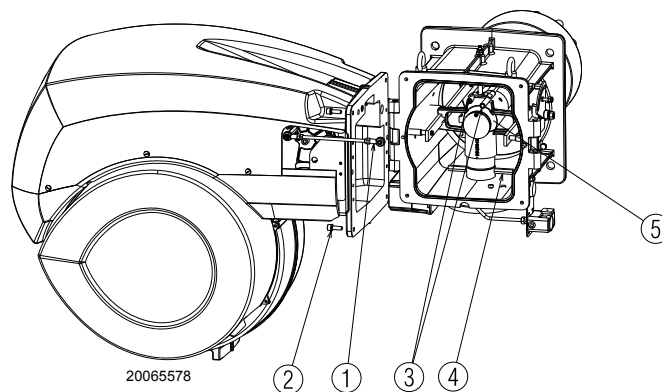

20065578
Fig. 13

5.9 Probe-electrode position



Check that the probe and the electrode are placed as in Fig. 14, according to the dimensions indicated.

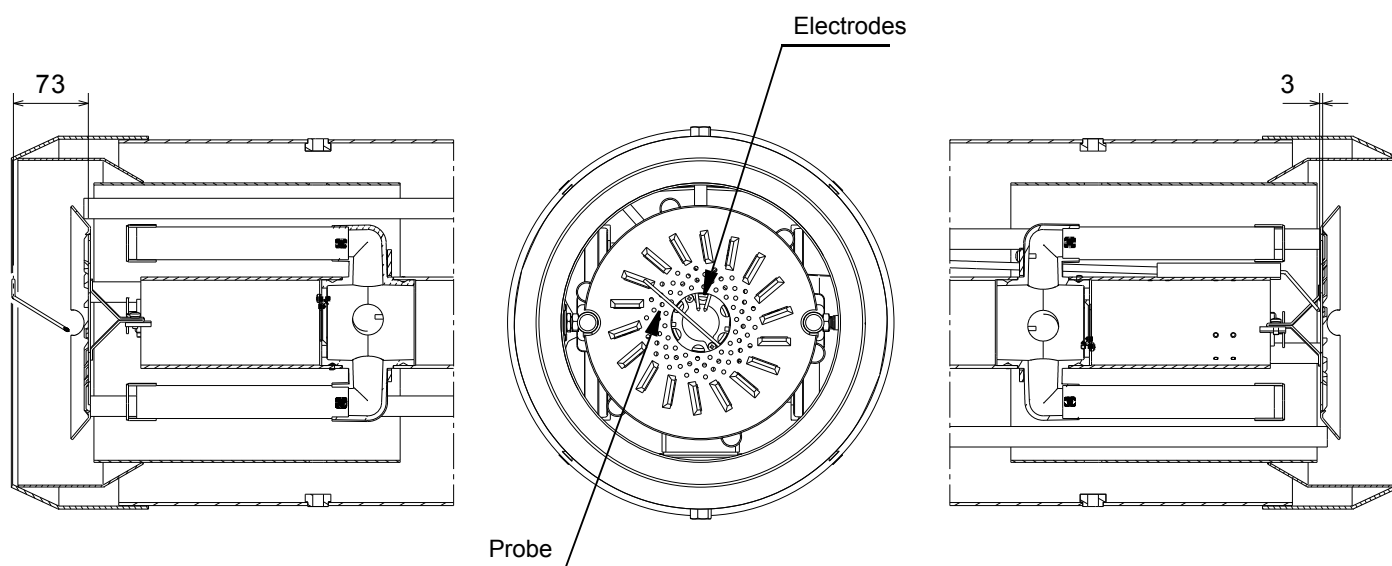

20050464
Fig. 14

5.10 Combustion head adjustment

The air damper servomotor 4)(Fig. 4 on page 12), beyond varying the air output according to the output demand, through a leverage varies the combustion head adjustment.

In the factory, the hole is adjusted for the minimum stroke (hole 1).



WARNING

Varying the tie-rod position on the holes 2) and 3) (Fig. 15) could cause instability during operation.



Pay attention to moving parts.
Danger of crushing of limbs!

If it is necessary to move the hinge to the right, the spacers 4)(Fig. 16) supplied with the burner must be mounted.

For the assembly proceed as follows:

- after you have unscrewed the nuts 2), remove the tie-rod 3),
- tighten the spacers 4) to spacer 1) and screw 5) respectively;
- mount the tie-rod and the nuts 2) again.

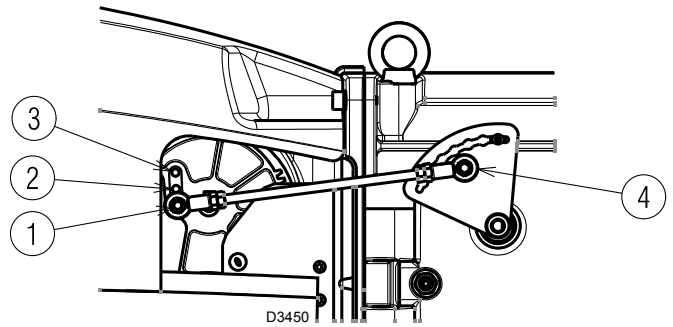

Fig. 15

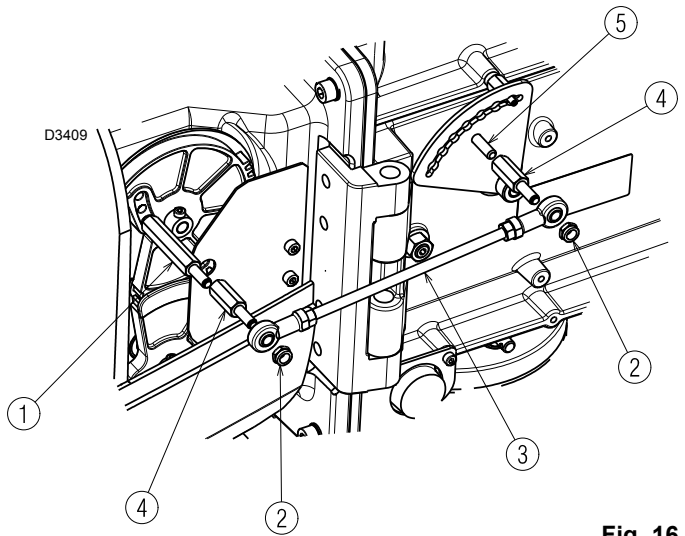

Fig. 16

5.11 Gas feeding



Explosion danger due to fuel leaks in the presence of a flammable source.

Precautions: avoid knocking, attrition, sparks and heat.

Make sure the fuel interception tap is closed before performing any operation on the burner.



WARNING

The fuel supply line must be installed by qualified personnel, in compliance with current standards and laws.

5.11.1 Gas feeding line

Key (Fig. 17 - Fig. 18 - Fig. 19 - Fig. 20)

- 1 Gas input pipe
- 2 Manual valve
- 3 Vibration damping joint
- 4 Pressure gauge with push-button cock
- 5 Filter
- 6A Includes:
 - filter
 - working valve
 - safety valve
 - pressure adjuster
- 6B Includes
 - working valve
 - safety valve
 - pressure adjuster
- 6C Includes
 - safety valve
 - working valve
- 6D Includes:
 - safety valve
 - working valve
- 7 Minimum gas pressure switch
- 8 Leak detection control, provided as an accessory or integrated, based on the gas train code. In compliance with the EN 676 standard, the leak detection control is compulsory for burners with maximum outputs over 1200 kW.
- 9 Gasket, for "flanged" versions only
- 10 Pressure adjuster
- P2 Upstream pressure of valves/adjuster
- P3 Upstream pressure of the filter
- L Gas train, supplied separately
- L1 The responsibility of the installer

MBC "threaded"

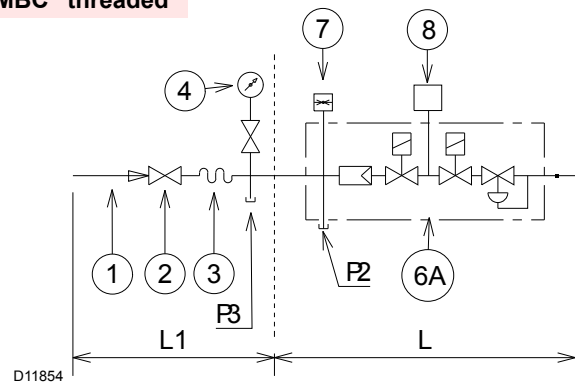

Fig. 17

MBC "flanged"

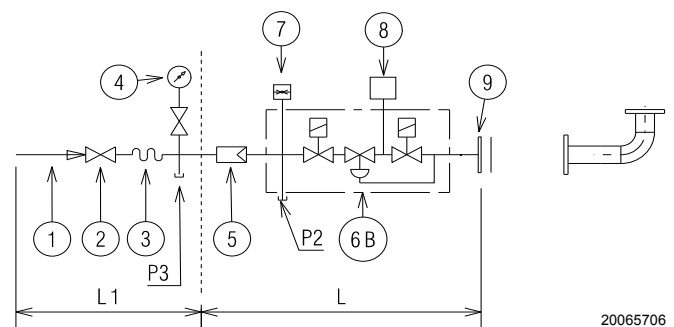

Fig. 18

DMV "flanged or threaded"

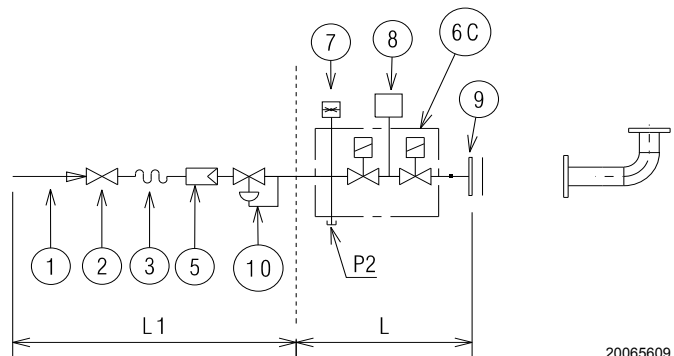

Fig. 19

CB "flanged or threaded"

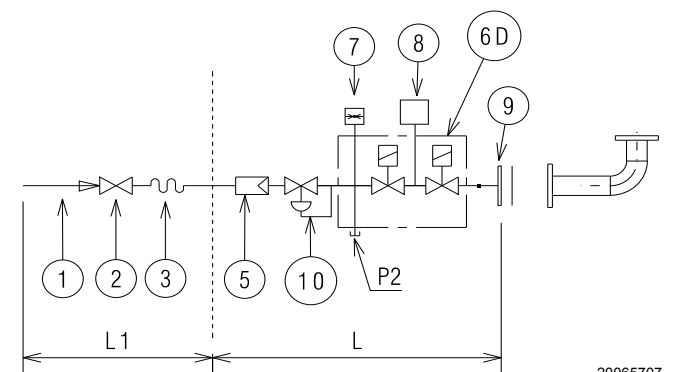

Fig. 20

5.11.2 Gas train

Approved according to standard EN 676 and provided separately from the burner.

To select the correct gas train model, refer to the supplied "Burner-gas train combination" manual.



Pay attention when handling the train: danger of crushing of limbs.



Make sure that the gas train is properly installed by checking for any fuel leaks.

5.11.3 Gas train installation

Disconnect the electrical power using the main switch.



Check that there are no gas leaks.

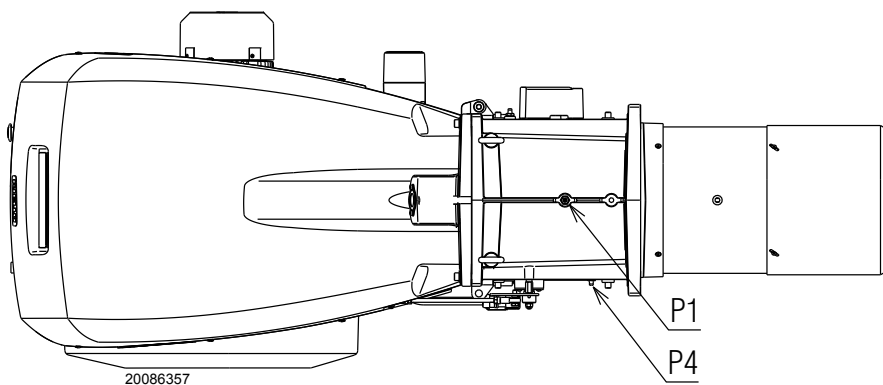

The operator must use the required equipment during installation.

**Fig. 21**

5.11.4 Gas pressure

The Tab. G indicates the pressure drop of the combustion head and the gas butterfly valve depending on the operating output of the burner.

The values shown in Tab. G refer to:

- Natural gas G 20 NCV 9.45 kWh/Sm³ (8.2 Mcal/Sm³)
- Natural gas G 25 NCV 8.13 kWh/Sm³ (7.0 Mcal/Sm³)

Column 1

Combustion head pressure drop.

Gas pressure measured at the test point P1)(Fig. 21), with:

- Combustion chamber at 0 mbar;
- Burner working at maximum modulating output;
- Combustion head adjusted as in page 20.

Column 2

Pressure loss at gas butterfly valve with maximum opening: 90°.

To calculate the approximate output at which the burner operates:

- subtract the combustion chamber pressure from the gas pressure measured at test point P1)(Fig. 21).
- Find, in the table Tab. G related to the burner concerned, the pressure value closest to the result of the subtraction.
- read the corresponding output on the left.

Example RS 300/EV C01 with G20 natural gas:

Operation at maximum modulating output

$$\begin{aligned} \text{Gas pressure at test point P1)(Fig. 21)} &= 18.7 \text{ mbar} \\ \text{Pressure in combustion chamber} &= 5 \text{ mbar} \\ 18.7 - 5 &= 13.7 \text{ mbar} \end{aligned}$$

A pressure of 13.7 mbar, column 1, corresponds in the table Tab. G to an output of 2500 kW.

This value serves as a rough guide; the effective output must be measured at the gas meter.

To calculate the required gas pressure at test point P1) (Fig. 21), set the maximum modulating output required from the burner operation:

- find the nearest output value in the table Tab. G for the burner in question.
- read, on the right (column 1), the pressure at the test point P1)(Fig. 21).
- Add this value to the estimated pressure in the combustion chamber.

Example RS 300/EV C01 with G20 natural gas:

Operation at maximum modulating output

$$\begin{aligned} \text{Gas pressure at an output of 2500 kW} &= 13.7 \text{ mbar} \\ \text{Pressure in combustion chamber} &= 5 \text{ mbar} \\ 13.7 + 5 &= 18.7 \text{ mbar} \end{aligned}$$

Pressure required at test point P1)(Fig. 21).

	kW	1 Δp (mbar)		2 Δp (mbar)	
		G 20	G 25	G 20	G 25
RS 300/EV C01 TL	1245	7.8	11.6	1.3	2.0
	1500	9.4	13.9	1.9	2.8
	1750	10.9	16.2	2.6	3.9
	2000	12.4	18.5	3.4	5.0
	2250	13.0	19.5	4.3	6.4
	2500	13.7	20.4	5.3	7.9
	2750	14.3	21.4	6.4	9.5
	3000	15.0	22.4	7.6	11.3
	3250	17.6	26.2	8.9	13.3
	3500	20.2	30.1	10.3	15.4
RS 400/EV C01 TL	3800	23.3	34.8	12.2	18.2
	1800	6.3	9.3	2.9	4.3
	2000	7.9	11.7	3.5	5.3
	2250	9.9	14.7	4.5	6.7
	2500	11.9	17.7	5.5	8.2
	2750	13.9	20.7	6.7	10.0
	3000	15.9	23.7	8.0	11.9
	3250	17.9	26.7	9.3	13.9
	3500	19.7	29.4	10.8	16.2
	3750	21.1	31.4	12.4	18.6
4000	22.4	33.5	14.2	21.1	
4250	27.4	40.8	16.0	23.8	
4500	32.5	48.4	17.9	26.7	

Tab. G

5.12 Electrical wiring

Notes on safety for the electrical wiring



- The electrical wiring must be carried out with the electrical supply disconnected.
- Electrical wiring must be made in accordance with the regulations currently in force in the country of destination and by qualified personnel. Refer to the wiring diagrams.
- The manufacturer declines all responsibility for modifications or connections different from those shown in the wiring diagrams.
- Check that the electrical supply of the burner corresponds to that shown on the identification label and in this manual.
- The burner has been type-approved for continuous use. This means they should compulsorily be stopped at least once every 72 hours to enable the control box to perform checks of its own start-up efficiency. Normally, burner stopping is guaranteed by the boiler's thermostat/pressure switch.
- If this is not the case, a time switch should be fitted in series to TL to stop the burner at least once every 72 hours. Refer to the wiring diagrams.
- The electrical safety of the device is obtained only when it is correctly connected to an efficient earthing system, made according to current standards. It is necessary to check this fundamental safety requirement. In the event of doubt, have the electrical system checked by qualified personnel. Do not use the gas tubes as an earthing system for electrical devices.
- The electrical system must be suitable for the maximum power absorption of the device, as indicated on the label and in the manual, checking in particular that the section of the cables is suitable for that level of power absorption.
- For the main power supply of the device from the electricity mains:
 - do not use adapters, multiple sockets or extensions;
 - make provisions for an omnipolar switch with a gap between the contacts of at least 3 mm (over-voltage category III), as required by current safety regulations.
- Do not touch the device with wet or damp body parts and/or in bare feet.
- Do not pull the electric cables.

Before carrying out any maintenance, cleaning or checking operations:



Disconnect the electrical supply from the burner by means of the main system switch.



Turn off the fuel interception tap.



Avoid condensate, ice and water leaks from forming.

If the cover is still present, remove it and proceed with the electrical wiring according to the wiring diagrams.

Use flexible cables in compliance with the EN 60 335-1 standard.

5.12.1 Supply cables and external connections passage

All the cables to be connected to the burner must be threaded through cable grommets. The use of the cable grommets can take various forms; by way of example see Fig. 22.

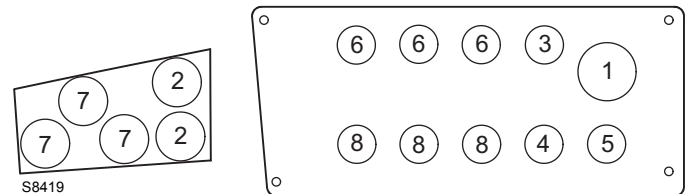

Fig. 22

Key (Fig. 22)

- 1 Electrical supply
- 2 Regulating probes
- 3 minimum gas pressure switch
- 4 Pressure switch kit for PGVP gas valve leak detection
- 5 Gas train
- 6 Consents/Safety
- 7 O₂ kit probes and O₂ kit supply
- 8 available



Perform all maintenance, cleaning or inspection operations and mount the casing again.

6 Start-up, calibration and operation of the burner

6.1 Notes on safety for the first start-up



The first start-up of the burner must be carried out by qualified personnel, as indicated in this manual and in compliance with the standards and regulations of the laws in force.



Check the correct working of the adjustment, command and safety devices.

6.2 Adjustments prior to ignition

Combustion head adjustment is already described on page 20.

In addition, the following adjustments must also be made:

- Open manual valves upline from the gas train.
- Adjust the minimum gas pressure switch to the start of the scale.
- Adjust the maximum gas pressure switch to the end of the scale.
- Adjust the air pressure switch to the start of the scale.
- Purge the air from the gas line.
We recommend using a plastic tube routed outside the building and to purge air until gas is smelt.
- Fit a U-type pressure gauge or a differential pressure gauge (Fig. 23), with socket (+) on the gas pressure of the pipe coupling and (-) in the combustion chamber.
The manometer readings are used to calculate MAX burner output using the Tab. G.
- Connect two lamps or testers to the two gas line solenoids to check the exact moment in which voltage is supplied. This operation is unnecessary if each of the two solenoids is equipped with a pilot light that signals voltage passing through.



Before starting up the burner, it is good practice to adjust the gas train so that ignition takes place in conditions of maximum safety, i.e. with gas delivery at the minimum.

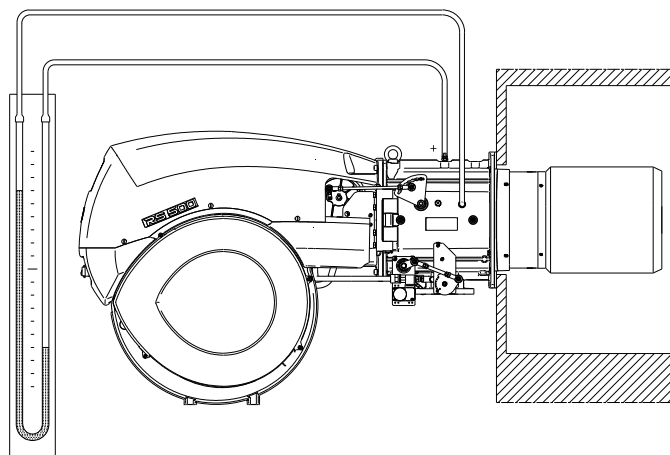

20073996

Fig. 23



Configure the Inverter according to the manual and the instructions supplied.

6.3 Burner start-up

Close all consents and safety devices and put the selector to position "AUTO" (Fig. 24).

Select the "MANUAL" mode (for further information refer to the relevant control box manual).



Make sure that the lights or testers connected to the solenoids, or the pilot lights on the solenoids themselves, indicate that no voltage is present. If voltage is present, stop the burner immediately and check the electrical connections.

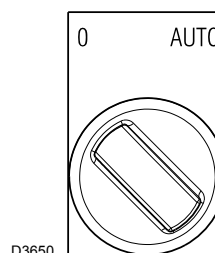

Fig. 24

6.4 Burner ignition

The burner should light after having performed the above steps. If the motor starts up, but the flame does not appear and the control box goes into lockout, reset it and wait for a new ignition attempt.

If ignition is still not achieved, it may be that gas is not reaching the combustion head within the safety time period of 3 seconds. In this case increase gas ignition delivery.

The arrival of gas at the pipe coupling is indicated by the U-type pressure gauge (Fig. 23).

Once the burner has fired, now proceed with global calibration operations.

Once regulations have been made, select the "AUTOMATIC" mode on the AZL display.

6.5 Combustion air adjustment

Fuel/combustion air synchronisation is done with the relevant servomotors (air and gas) by logging a calibration curve by means of the electronic cam.

It is advisable, to reduce the loss and for a wide calibration field, to adjust the servomotors to the maximum of the output used, the nearest possible to the maximum opening (90°).

On the gas butterfly valve, fuel step according to the burner output required, with servomotor completely open, is carried out by the pressure stabiliser placed on the gas train.

If the O₂ control kit is present, follow the commissioning operations indicated in the relevant LMV manual, supplied at the time of training by the Technical Assistance Service.

6.5.1 Air adjustment for maximum output

- Adjust the servomotor to maximum opening (nearly 90°) so that the air butterfly valves are entirely open;
- Loosen the screw 2)(Fig. 25) placed under the burner suction line and close progressively the grid 1) until the required output is reached.

Steps in suction line are not necessary only in case in which the burner is working at maximum of the firing rate on page 10.



It is advisable to reach the maximum output required manually and, just after defining the steps in suction line, the gas pressure and the combustion head adjustment, carry out complete calibration and logging of the fuel/combustion synchronisation curves.

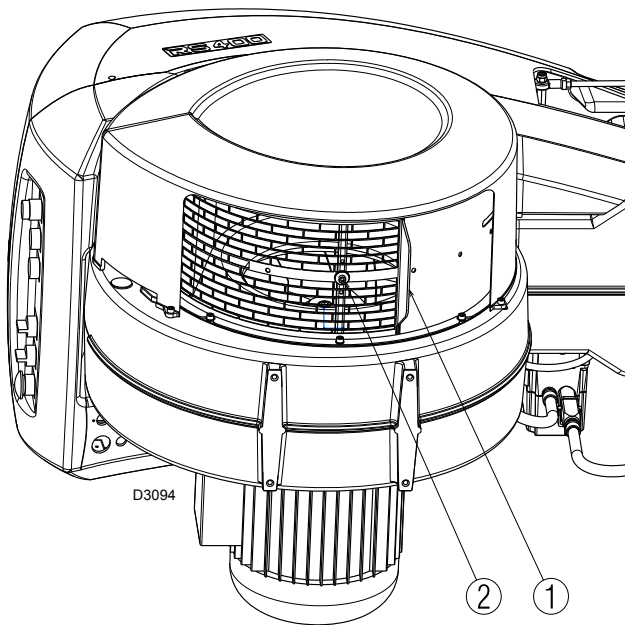

Fig. 25

6.5.2 Air/fuel adjustment and output modulation system

The air/gas regulator and output modulation system equipping **RS/EV** series burners performs a number of integrated functions in a single control device in order to optimise burner function, in both individual installations and in combination with other units (e.g. double furnace boiler or multiple heat generators in parallel).

The basic system functions control:

- 1 the dosage of the air and fuel through positioning using direct servocommands of the relevant valves eliminating the possible play in the calibration systems with mechanical cam lever mechanisms, used on traditional modulating burners;
- 2 the modulation of the burner output in accordance with the load required by the system, with maintenance of the pressure or temperature of the boiler at the operating values set.
- 3 the fine, continuous adjustment of the air flow rate according to the gas analysis made at the flue (O₂); this function requires the O₂ kit, containing the PLL module and the QGO₂ sensor;
- 4 the measurement of the combustion yield (this function requires the O₂ kit);
- 5 the sequence (cascade adjustment) of several boilers, suitably connected.

Further interfaces and communication functions with computers, for remote control or integration in central supervision systems are available on the basis of the configuration of the system.



The first start up and every further internal setting operation of the adjustment system or the expansion of the base functions require access by means of password and are to be carried out by service personnel who are especially trained for the internal programming of the instrument and the specific application created with this burner.

The specific reference manual for the instrument is supplied during training to provide technical assistance.

6.6 Pressure switch adjustment

6.6.1 Air pressure switch - check CO

Adjust the air pressure switch (Fig. 26) after performing all other burner adjustments with the air pressure switch set to the start of the scale.

With the burner operating at MIN output, insert a combustion analyser in the stack, slowly close the suction inlet of the fan (for example, with a piece of cardboard) until the CO value does not exceed 100 ppm.

Slowly turn the appropriate knob clockwise until the burner goes into lockout.

Check the indication of the arrow pointing upwards on the graduated scale. Turn the knob clockwise again, until the value shown on the graduated scale corresponds with the arrow pointing downwards, and so recovering the hysteresis of the pressure switch (shown by the white mark on a blue background, between the two arrows).

Now check the correct start-up of the burner.

If the burner locks out again, turn the knob anticlockwise a little bit more.

On **RS 300/EV C01** burners the air pressure switch is fitted in a "differential" mode, that is, with two pipes connected to the specific pressure test points "+" and "-" 23)-24)(Fig. 4 on page 12).

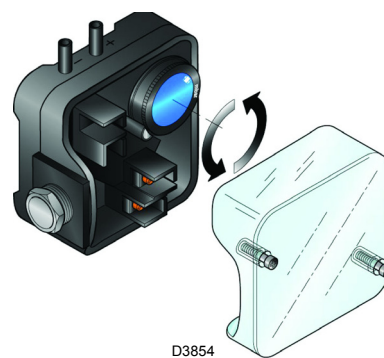

Fig. 26

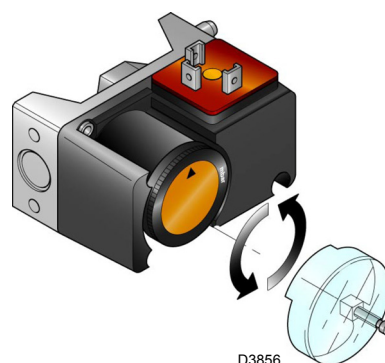

Fig. 27

6.6.2 Maximum gas pressure switch

Adjust the maximum gas pressure switch (Fig. 27) after performing all other burner adjustments with the maximum gas pressure switch set to the end of the scale.

With the burner operating at maximum output, lower adjustment pressure by slowly turning the relative knob anticlockwise until the burner locks out.

Turn the knob clockwise by 2 mbar and repeat the start-up of the burner.

If the burner locks out again, turn the knob clockwise again by 1 mbar.

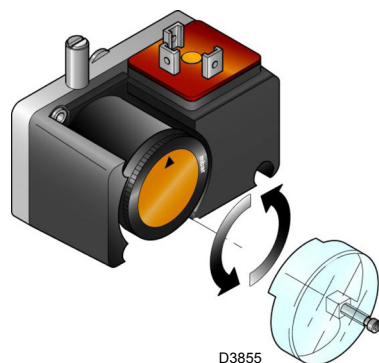

Fig. 28

6.6.3 Minimum gas pressure switch

Adjust the minimum gas pressure switch (Fig. 28) after performing all the other burner adjustments with the pressure switch set to the start of the scale.

With the burner operating at maximum output, increase adjustment pressure by slowly turning the relative knob clockwise until the burner locks out.

Then turn the knob anticlockwise by 2 mbar and repeat burner start-up to ensure it is uniform.

If the burner locks out again, turn the knob anticlockwise again by 1 mbar.

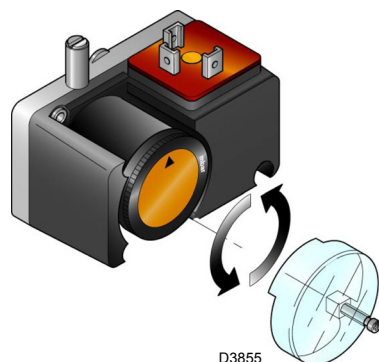

Fig. 29

6.6.4 PVP pressure switch kit

Adjust the pressure switch for the leak detection control (Fig. 29) according to the instructions supplied with the kit.

7 Maintenance

7.1 Notes on safety for the maintenance

The periodic maintenance is essential for the good operation, safety, yield and duration of the burner.

It allows you to reduce consumption and polluting emissions and to keep the product in a reliable state over time.



The maintenance interventions and the calibration of the burner must only be carried out by qualified, authorised personnel, in accordance with the contents of this manual and in compliance with the standards and regulations of current laws.

Before carrying out any maintenance, cleaning or checking operations:



Disconnect the electrical supply from the burner by means of the main system switch.



Turn off the fuel interception tap.



Wait for the components in contact with heat sources to cool down completely.

7.2 Maintenance programme

7.2.1 Maintenance frequency



The gas combustion system should be checked at least once a year by a representative of the manufacturer or another specialised technician.

7.2.2 Checking and cleaning



The operator must use the required equipment during maintenance.

Combustion

The optimum calibration of the burner requires an analysis of the flue gases.

Significant differences with respect to the previous measurements indicate the points where most care should be exercised during maintenance.

Combustion head

Open the burner and make sure that all components of the combustion head are in good condition, not deformed by the high temperatures, free of impurities from the surroundings and correctly positioned.

Burner

Check that there are not excess wear or loosen screws.

Clean the outside of the burner.

Fan

Check to make sure that no dust has accumulated inside the fan or on its blades, as this condition will cause a reduction in the air flow rate and provoke polluting combustion.

Boiler

Clean the boiler as indicated in its accompanying instructions in order to maintain all the original combustion characteristics intact, especially the flue gas temperature and combustion chamber pressure.

Electrical current to UV cell

Clean the glass cover from any dust that may have accumulated. To remove the photocell, pull out outwards; it is only pressed in. Min value for a good work: 70 µA.

If the value is lower, it could be due to:

- exhausted photocell
- low voltage (lower than 187 V)
- bad regulation of the burner

In order to measure the current, use a microammeter of 100 µA d.c., connected in series to the photocell, as in the scheme, with a capacitor of 100 µF - 1V d.c. at the same level of the instrument.

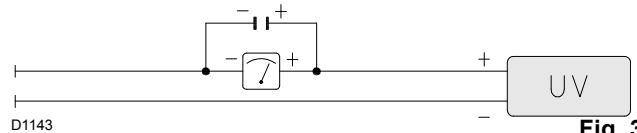

Gas leaks

Make sure that there are no gas leaks on the pipe between the gas meter and the burner.

Gas filter

Change the gas filter when it is dirty.

Combustion

If the combustion values measured before starting maintenance do not comply with applicable legislation or do not indicate efficient combustion, consult the Tab. H or contact our Technical Support Service to implement the necessary adjustments.

It is advisable to set the burner according to the type of gas used and following the indications in Tab. H.

EN 676		Air excess			
		Max. output. $\lambda \leq 1.2$		Min. output $\lambda \leq 1.3$	
GAS	CO ₂ theoretical max. 0% O ₂	CO ₂ % Calibration		CO	NO _x
		$\lambda = 1.2$	$\lambda = 1.3$	mg/kWh	mg/kWh
G 20	11.7	9.7	9.0	≤ 100	≤ 170
G 25	11.5	9.5	8.8	≤ 100	≤ 170
G 30	14.0	11.6	10.7	≤ 100	≤ 230
G 31	13.7	11.4	10.5	≤ 100	≤ 230

Tab. H

7.3 Opening the burner



DANGER

Disconnect the electrical supply from the burner by means of the main system switch.



DANGER

Turn off the fuel interception tap.



Wait for the components in contact with heat sources to cool down completely.

- Remove the tie-rod 1)(Fig. 31) of the head movement lever, undoing the nut 2).
- Disconnect the socket 3) of the gas servomotor.
- Disconnect the socket 4) of the gas pressure switch.
- Remove the screws 5).

At this point, it is possible to open the burner on the hinge.

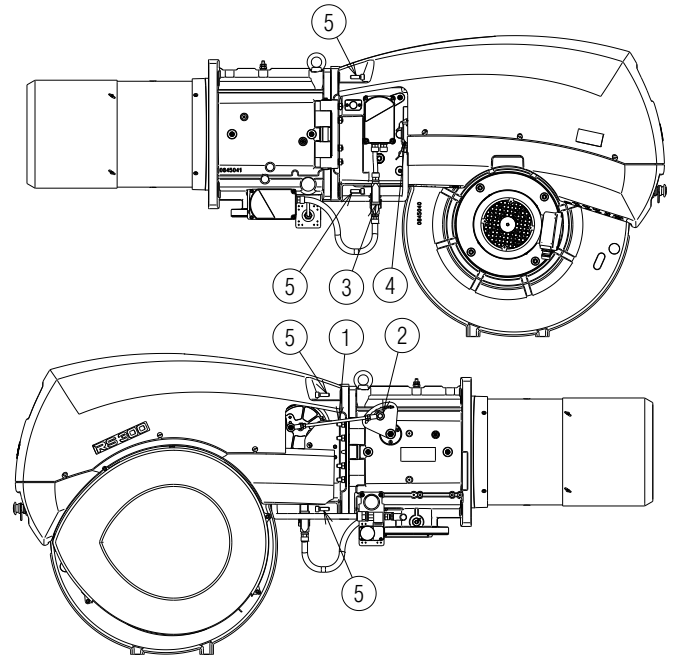

20086358

Fig. 31

7.4 Closing the burner

Refit following the steps described but in reverse order; refit all burner components as they were originally assembled.



Carry out all maintenance work and mount the casing again.

8 **Faults - Possible causes - Solutions**

If faults arise in ignition or operations, the burner performs a “safety stop”, which is signalled by the red burner lockout LED.

The display visualises alternately the lockout code and the relative diagnostic. To reset the start-up conditions, refer to the “Reset procedure” indicated in the control box manual supplied.

When the burner starts again, the red LED goes out and the control box is reset.

**WARNING**

In the event the burner stops, in order to prevent any damage to the installation, do not unblock the burner more than twice in a row. If the burner locks out for a third time, contact the customer service.

**DANGER**

In the event there are further lockouts or faults with the burner, the maintenance interventions must only be carried out by qualified, authorised personnel, in accordance with the contents of this manual and in compliance with the standards and regulations of current laws.

A Appendix - Accessories**Inverter kit (VSD)**

Burner	Max. output (kW)	Code
RS 300-400/EV C01	7.5	3010379

Kit for modulating operation

Burner	Output regulator	Code
All models	RWF 40 BASIC	3010356
All models	RWF 40 BASIC	3010357

Burner	Probe	Adjustment field	Code
All models	PT 100 temperature	- 100...+ 500°C	3010110
All models	4 - 20 mA pressure	0...2.5 bar	3010213
All models	4 - 20 mA pressure	0...16 bar	3010214

AZL Kit (display and operating unit) - (Russia only)

Burner	Code
All models	3010469

Infrared flame detector

Burner	Code
All models	3010354

Oxygen control kit (QGO₂)

Burner	Code
All models	3010378

Efficiency kit with oxygen control kit

Burner	Code
All models	3010377

Kit software interface (ACS 450)

Burner	Code
All models	3010388

Soundproofing box kit

Burner	Type	dB(A)	Code
All models	C7	10	3010376

GPL kit

Burner	Code
RS 300/EV C01 TL	3010445
RS 400/EV C01 TL	20012916

Continuous purging kit

Burner	Code
All models	3010094

Spacer kit

Burner	Code
All models	20008903

Gas trains in compliance with EN 676

Please refer to manual.

B Appendix - Electrical panel layout

1	Index of layouts
2	Indication of references
3	Single-wire output layout
4	LMV52.... functional layout
5	LMV52.... functional layout
6	LMV52.... functional layout
7	LMV52.... functional layout
8	LMV52.... functional layout
9	LMV52.... functional layout Functional layout LMV52.... with O ₂ kit
10	LMV52.... functional layout
11	PLL52../QGO20...functional layout PLL52../QGO20... functional layout with O ₂ kit
12	Electrical wiring to be carried out by the installer
13	Electrical wiring to be carried out by the installer

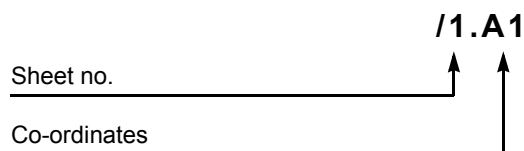
2 Indication of references

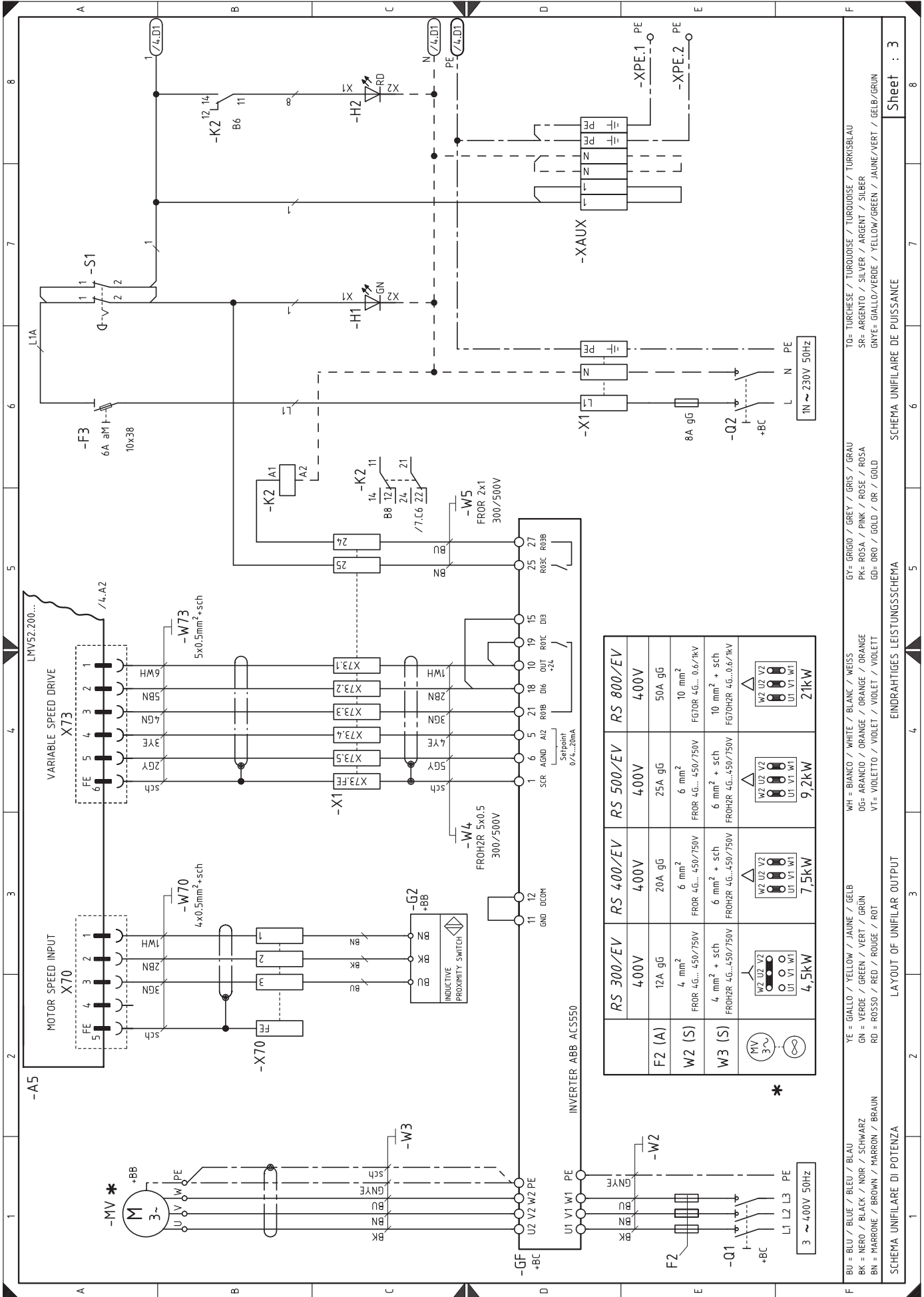

Sheet : 3

SCHEMA UNIFILAIRE DE PUISSANCE

EINDRAHTIGES LEISTUNGSSCHEMA

LAYOUT OF UNIFILAR OUTPUT

SCHEMA UNIFILARE DI POTENZA

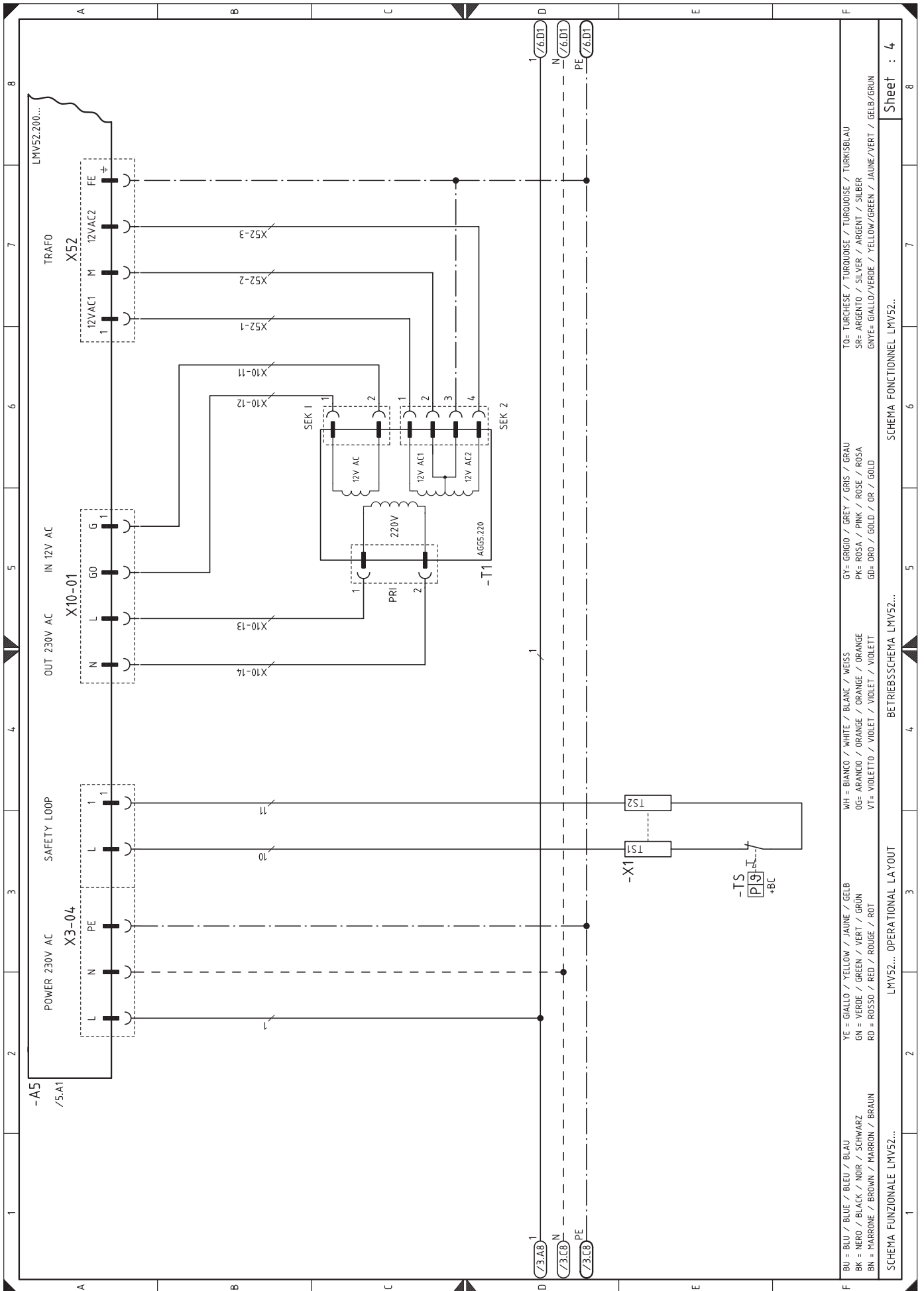

BU = BLU / BLUE / BLEU / BLAU	WH = BIANCO / WHITE / BLANK / WEISS	GY = GRIGIO / GREY / GRIS / GRAU	TO = TURCHESE / TURQUOISE / TURKOISE / TURKISBLAU
BN = NERO / BLACK / NOIR / SCHWARZ	OG = ARANCIO / ORANGE / ORANGE / ORANGE	PK = ROSA / PINK / ROSE / ROSA	SR = ARGENTO / SILVER / ARGENT / SILBER
BN = MARRONE / BROWN / MARRON / BRAUN	VI = VIOLETTA / VIOLET / VIOLET / VIOLETT	GD = ORO / GOLD / OR / GOLD	GNVE = GIALLO/VERDE / YELLOW/GREEN / JAUNE/VERT / GELB/GRUN
YE = GIALLO / YELLOW / JAUNE / GELB			
GN = VERDE / GREEN / VERT / GRÜN			
RD = ROSSO / RED / ROUGE / ROT			

SCHEMA FUNZIONALE LMV52... LMV52... OPERATIONAL LAYOUT SCHEMA FONCTIONNEL LMV52... Sheet : 4

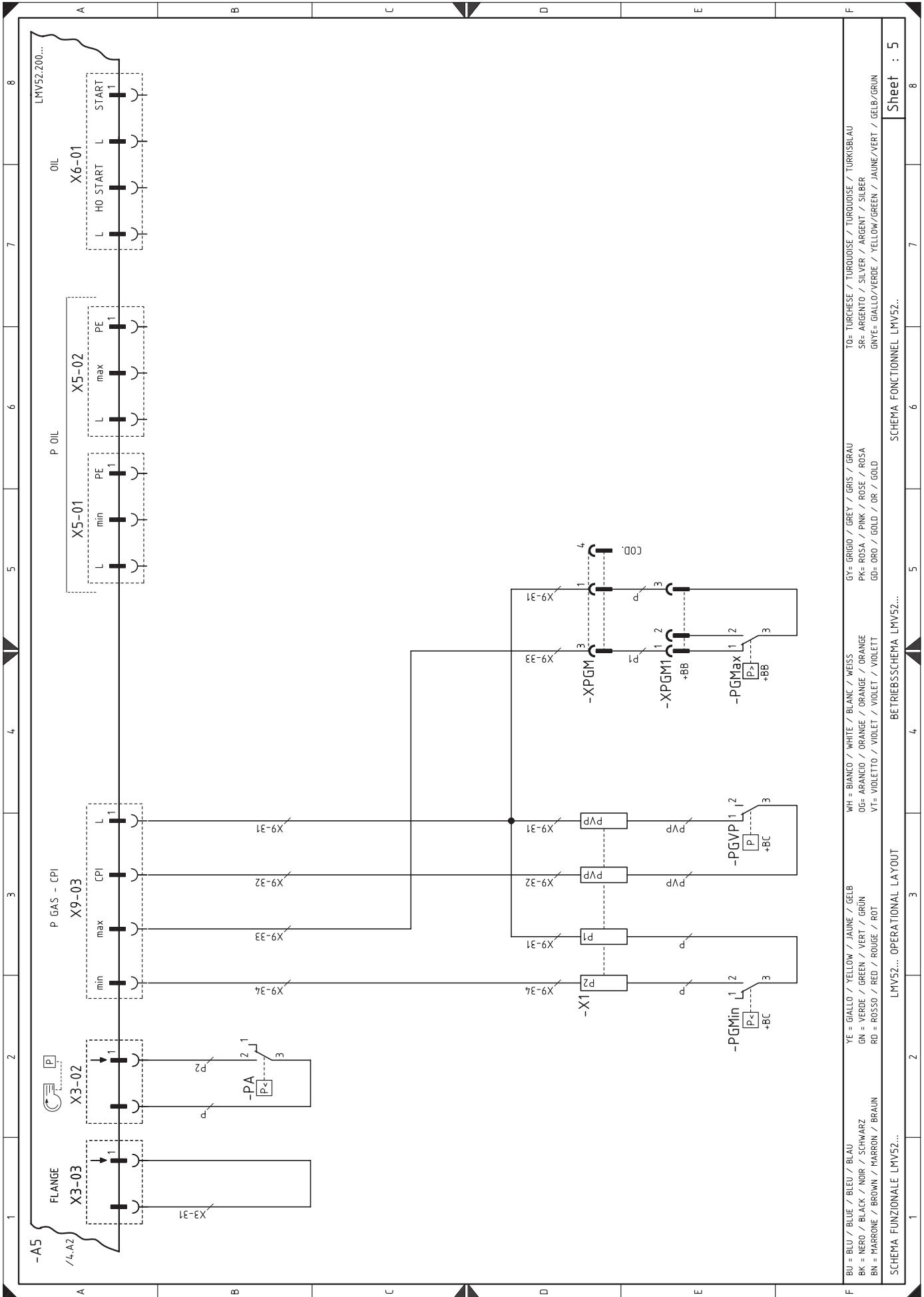

BU = BLU / BLUE / BLEU / BLAU
 BK = NERO / BLACK / NOIR / SCHWARZ
 BN = MARRONE / BROWN / MARRON / BRAUN
 YE = GIALLO / YELLOW / JAUNE / GELB
 GN = VERDE / GREEN / VERT / GRÜN
 RD = ROSSO / RED / ROUGE / ROT
 WH = BIANCO / WHITE / BLANC / WEISS
 OG = ARANCIO / ORANGE / ORANGE / ORANGE
 VT = VIOLETTA / VIOLET / VIOLET / VIOLETT
 GY = GRIGIO / GREY / GRIS / GRAU
 PK = ROSA / PINK / ROSE / ROSA
 GP = ORO / GOLD / OR / GOLD
 TO = TURCHESE / TURQUOISE / TURQUOISE / TURKISBLAU
 SR = ARGENTO / SILVER / ARGENT / SILBER
 GNYE = GIALLO/VERDE / YELLOW/GREEN / JAUNE/VERT / GELB/GRÜN

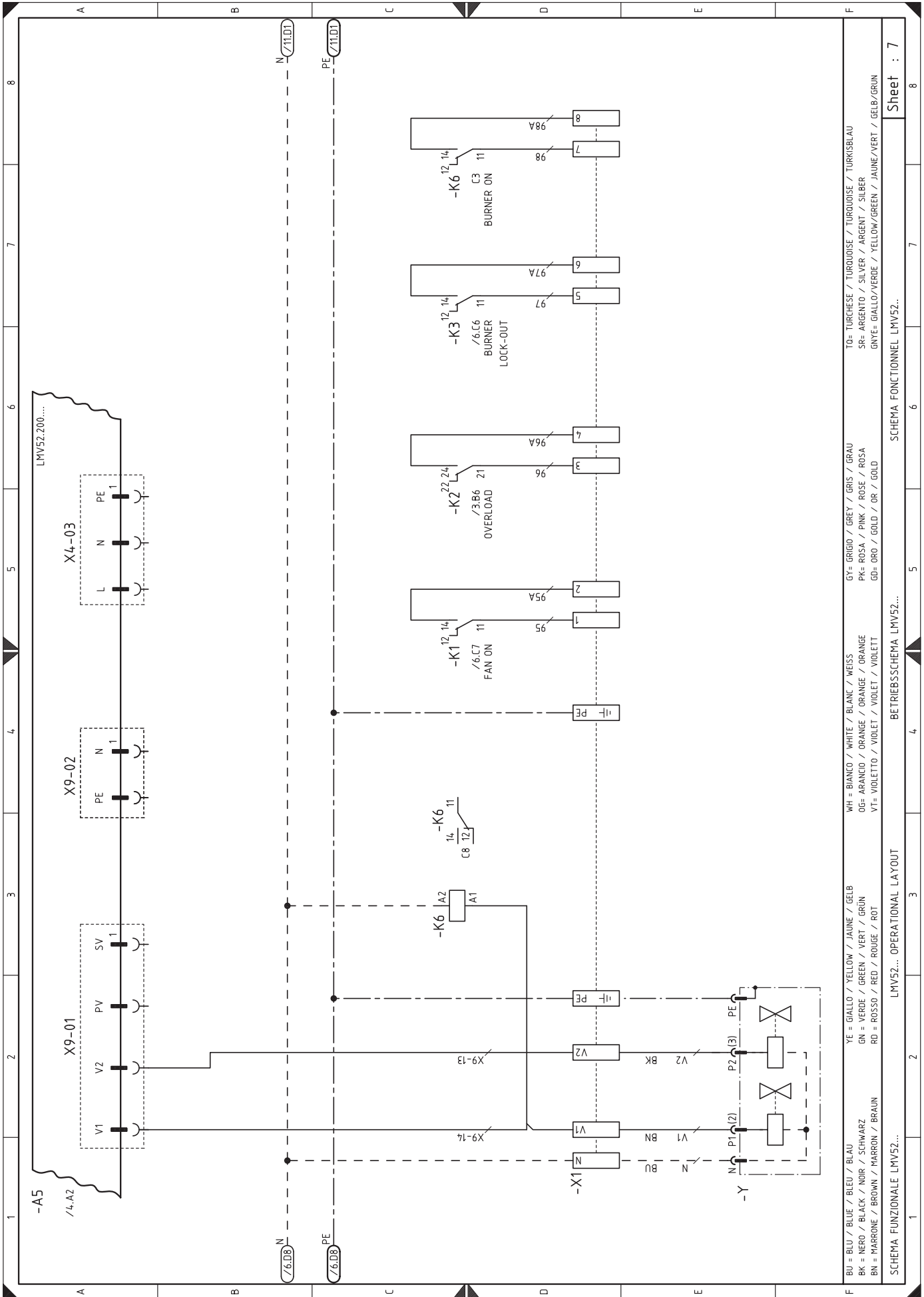

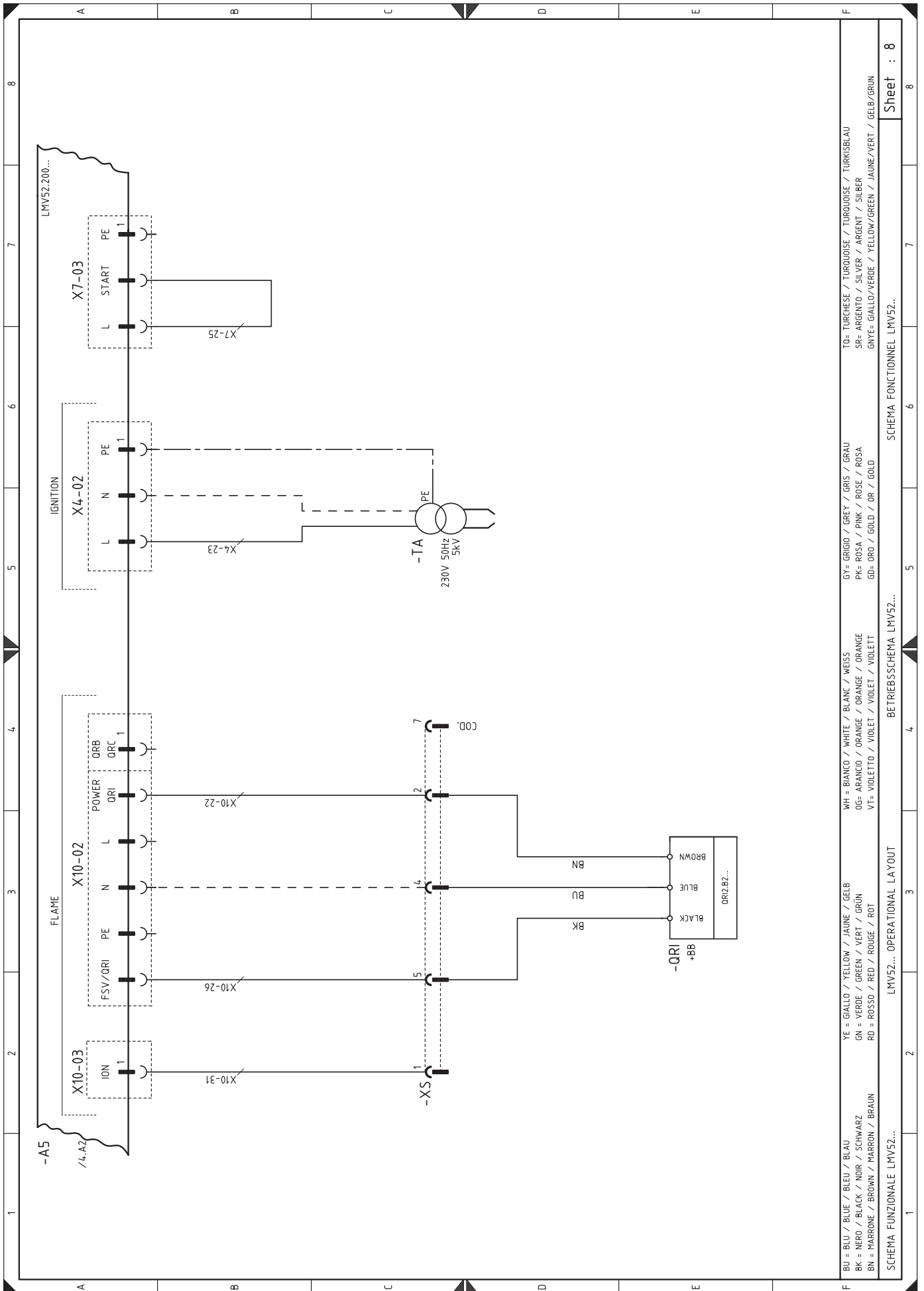

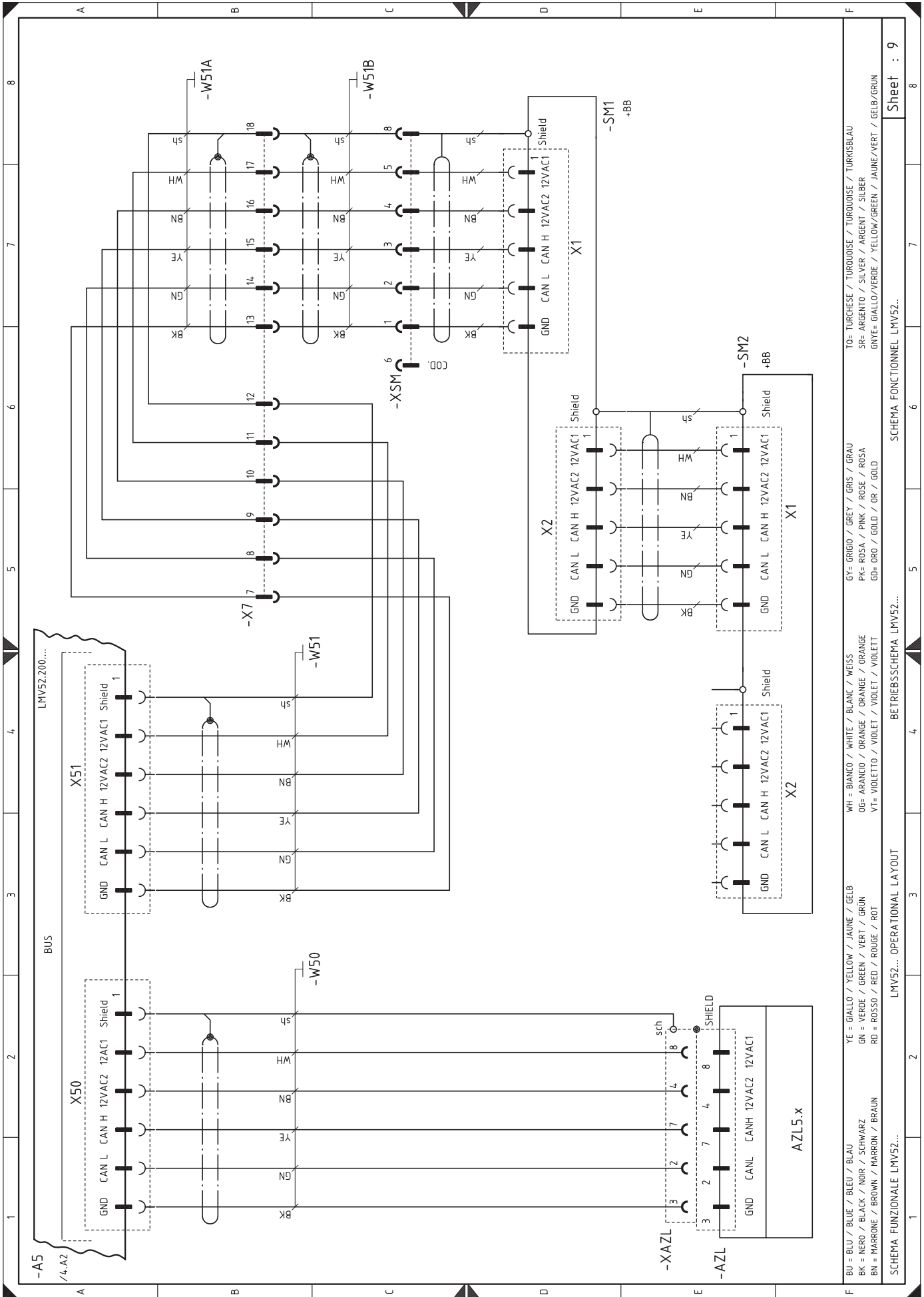

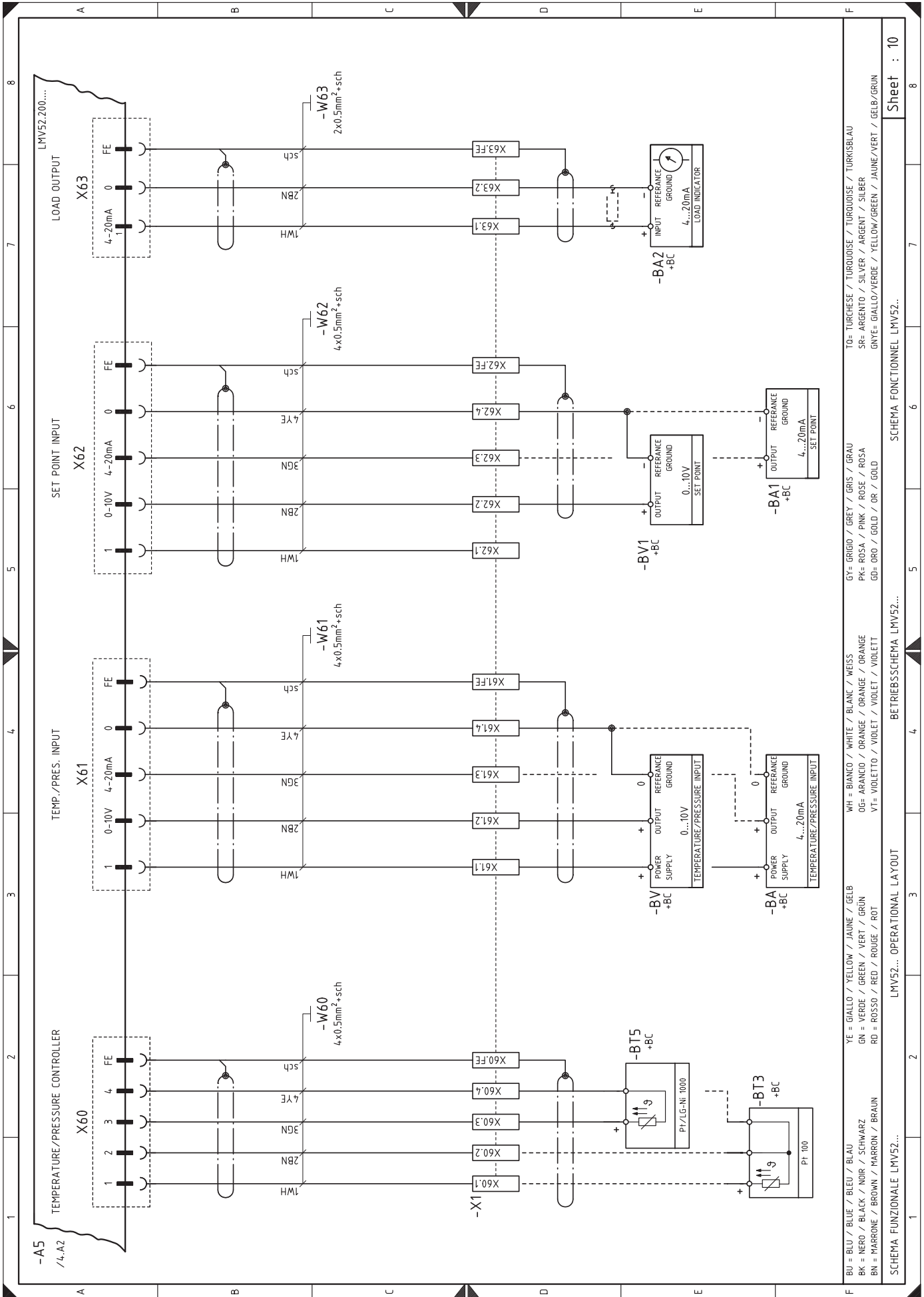

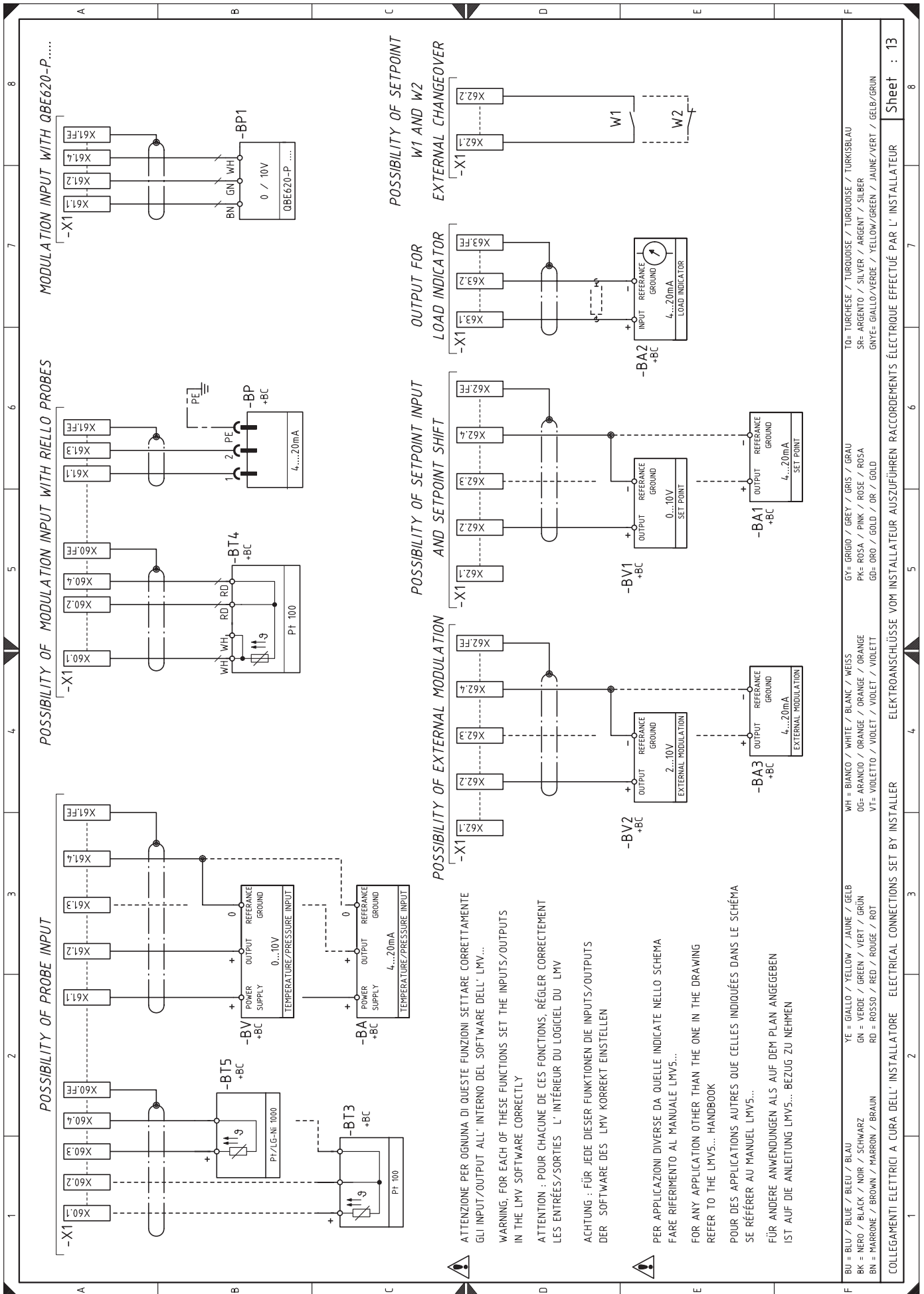

BU = BLU / BLUE / BLEU / BLAU	YE = GIALLO / YELLOW / JAUNE / GELB	WH = BIANCO / WHITE / BLANK / WEISS	GY = GRIGIO / GREY / GRIS / GRAU	TO = TURCHESE / TURQUOISE / TURKOISE / TURKISBLAU
BK = NERO / BLACK / NOIR / SCHWARZ	GN = VERDE / GREEN / VERT / GRÜN	OR = ARANCIO / ORANGE / ORANGE / ORANGE	PK = ROSA / PINK / ROSE / ROSA	SR = ARGENTO / SILVER / ARGENT / SILBER
BN = MARRONE / BROWN / MARRON / BRAUN	RD = ROSSO / RED / ROUGE / ROT	VI = VIOLETTA / VIOLET / VIOLET / VIOLETT	GD = ORO / GOLD / OR / GOLD	GNVE = GIALLO/VERDE / YELLOW/GREEN / JAUNE/VERT / GELB/GRÜN

COLLEGAMENTI ELETTRICI A CURA DELL' INSTALLATORE ELECTRICAL CONNECTIONS SET BY INSTALLER ELEKTROANSCHLÜSSE VOM INSTALLATEUR EFFECTUË PAR L' INSTALLATEUR

Wiring layout key

A5	Electronic cam	XAUX	Auxiliary terminal board
A6	O2 module PLL type..	XAZL	AZL plug on board
AZL	Display and calibration unit	XO2	O2 sensor terminal board
BA	Input in current DC 4...20 mA	XPGM,1	Maximum gas pressure switch connector
BA1	Input in current DC 4...20 mA to modify remote set-point	XS	Flame sensors connector
BA2	Load indicator	XSM	Air and gas servomotor connector
BA3	Input in current DC 4...20 mA		
BP	Pressure probe		
BP1	Pressure probe		
BT3	Probe Pt100, 3 wires		
BT4	Probe Pt100, 3 wires		
BT5	PT/LG-Ni1000 probe		
BV	Input in voltage DC 0...10V		
BV1	Input in voltage DC 0...10V to modify remote setpoint		
CN1	Ionisation probe connector		
F3	Auxiliary fuse		
GF	Inverter		
G2	Rpm sensor (with Inverter kit only)		
G10	O2 sensor OGO20.. type		
G20	Combustion fume temperature sensor probe		
G30	Air temperature control probe		
H1	Light signalling of mains live state		
H2	Fan motor lock-out warning lamp		
ION	Ionisation probe		
K1	Volt-free fan on contacts output relay		
K2	Clean contacts output relay motor lockout		
K3	Clean contacts output relay for burner lockout		
K6	Clean contacts output relay burner switched on		
MV	Fan motor		
PA	Air pressure switch		
PE	Burner earth		
PGMax	Maximum gas pressure switch		
PGMin	Minimum gas pressure switch		
PGVP	Gas pressure switch for valve leak detection control device		
QRI	Infrared sensor		
RS	Remote reset button		
S1	Emergency stop button		
S2	Automatic / off selector		
SH3	Burner reset button and light signalling of lock-out signal		
SM1	Air servomotor		
SM2	Gas servomotor		
T1	Electronic cam transformer		
TA	Ignition transformer		
TL	Limit thermostat/pressure switch		
TS	Safety thermostat/pressure switch		
Y	Gas regulator valve + gas safety valve		
X1	Main terminal supply board		
X6.7	O2 kit plugs-sockets		
X70	RPM sensor terminal board		

RIELLO

RIELLO S.p.A.
I-37045 Legnago (VR)
Tel.: +39.0442.630111
[http:// www.riello.it](http://www.riello.it)
[http:// www.riello.com](http://www.riello.com)