

RLS 800÷1200/M MX SERIES

RLS/M burners are characterised by a modular monoblock structure that means all necessary components can be combined in a single unit thus making installation easier, faster and, above all, more flexible.

The series covers a firing range from 1750 to 11500 kW, and it has been designed for use in hot water boilers, overheated water boilers as well as steam boilers.

Operation can be "two stage progressive" or alternatively "modulating", for both fuels, light oil and gas, with the installation of a PID logic regulator .

The mechanical cam device of regulation allows to catch up a high modulation ratio on all firing rates range. The burners can, therefore, supply with precision the demanded power, guaranteeing a high efficiency system level and the stability setting, obtaining fuel consumption and operating costs reduction.

The combustion head guarantees reduced polluting emissions (NOx < 80 mg/kWh on gas operation). An exclusive design guarantees low sound emissions, low electrical consumption, easy use and maintenance.



RLS 800/M MX	1750/3500 ÷ 8000 kW
RLS 1000/M MX	1200/3750 ÷ 10600 kW
RLS 1200/M MX	1500/5500 ÷ 11500 kW

Low NOx Modulating Dual Fuel Burners

RLS 800÷1200/M MX SERIES

FIRING RATES

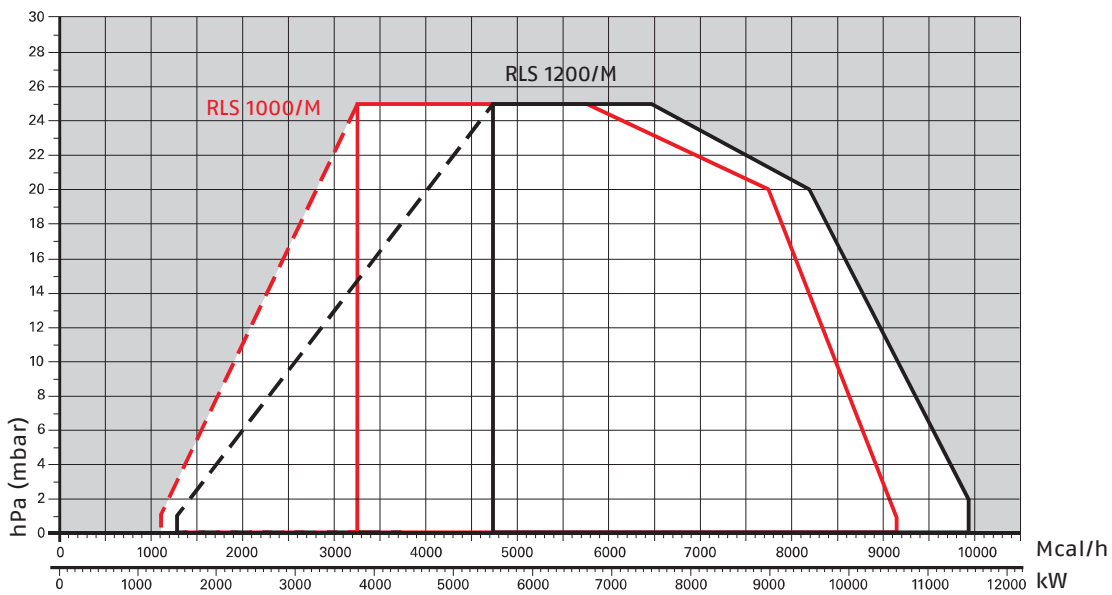
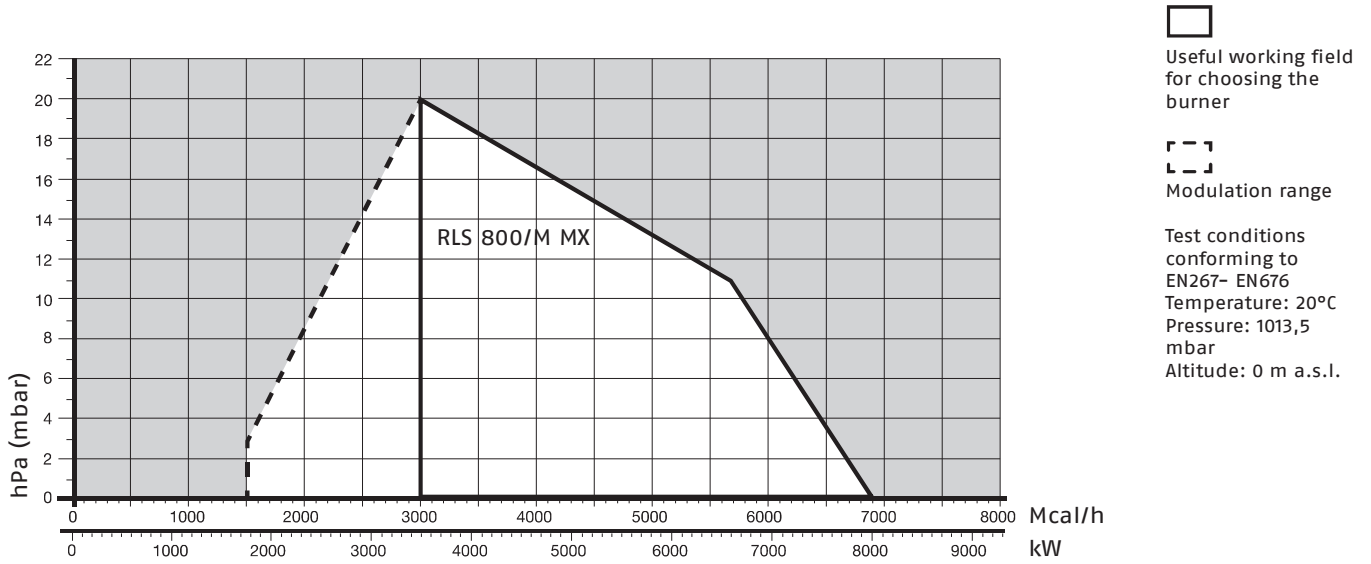

Overall dimensions (mm)

BURNER

RLS 800/M MX

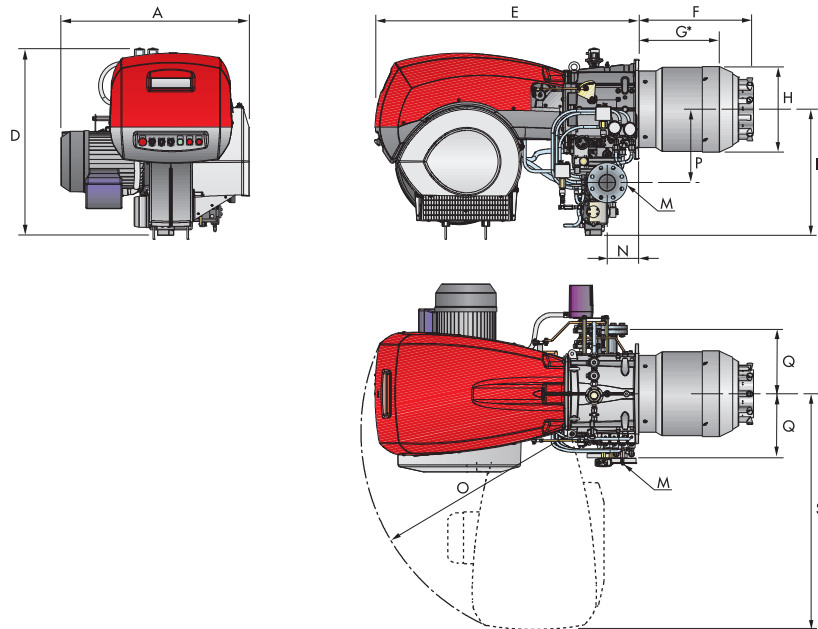

RLS 1000-1200/M MX

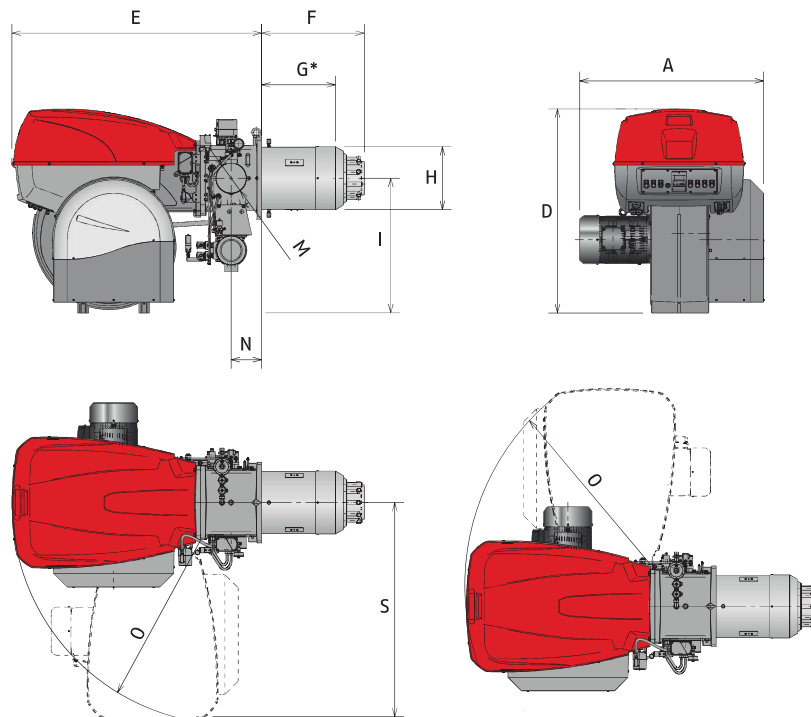

MODEL	A	D	E	F	G*	H	I	M	N	O	P	Q	S
▶ RLS 800/M MX	940	937	1325	558	382	428	630	DN80	164	1055	427	320	1190
▶ RLS 1000/M MX	1206	1338	1637	674	484	413	885	DN80	200	1350	-	-	1425
▶ RLS 1200/M MX	1250	1338	1637	658	465	456	885	DN80	200	1350	-	-	1425

* Maximum depth of the boiler door including the depth of the burner flange insulating gasket.

Low NOx Modulating Dual Fuel Burners

RLS 800÷1200/M MX SERIES

Overall dimensions (mm)

BURNER - BOILER MOUNTING FLANGE

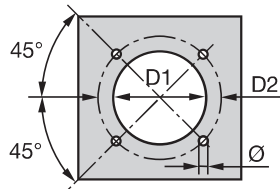

MODEL	D1	D2	Ø
▶ RLS 800/M MX	440	495	M18
▶ RLS 1000/M MX	460	608	M20
▶ RLS 1200/M MX	500	608	M20

PACKAGING

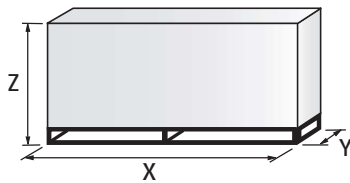

MODEL	X	Y	Z	kg
▶ RLS 800/M MX	2190	1110	1450	320
▶ RLS 1000/M MX	2400	1400	1595	550
▶ RLS 1200/M MX	2400	1400	1595	600

RLS 800÷1200/M MX SERIES

Specification

DESIGNATION OF SERIES

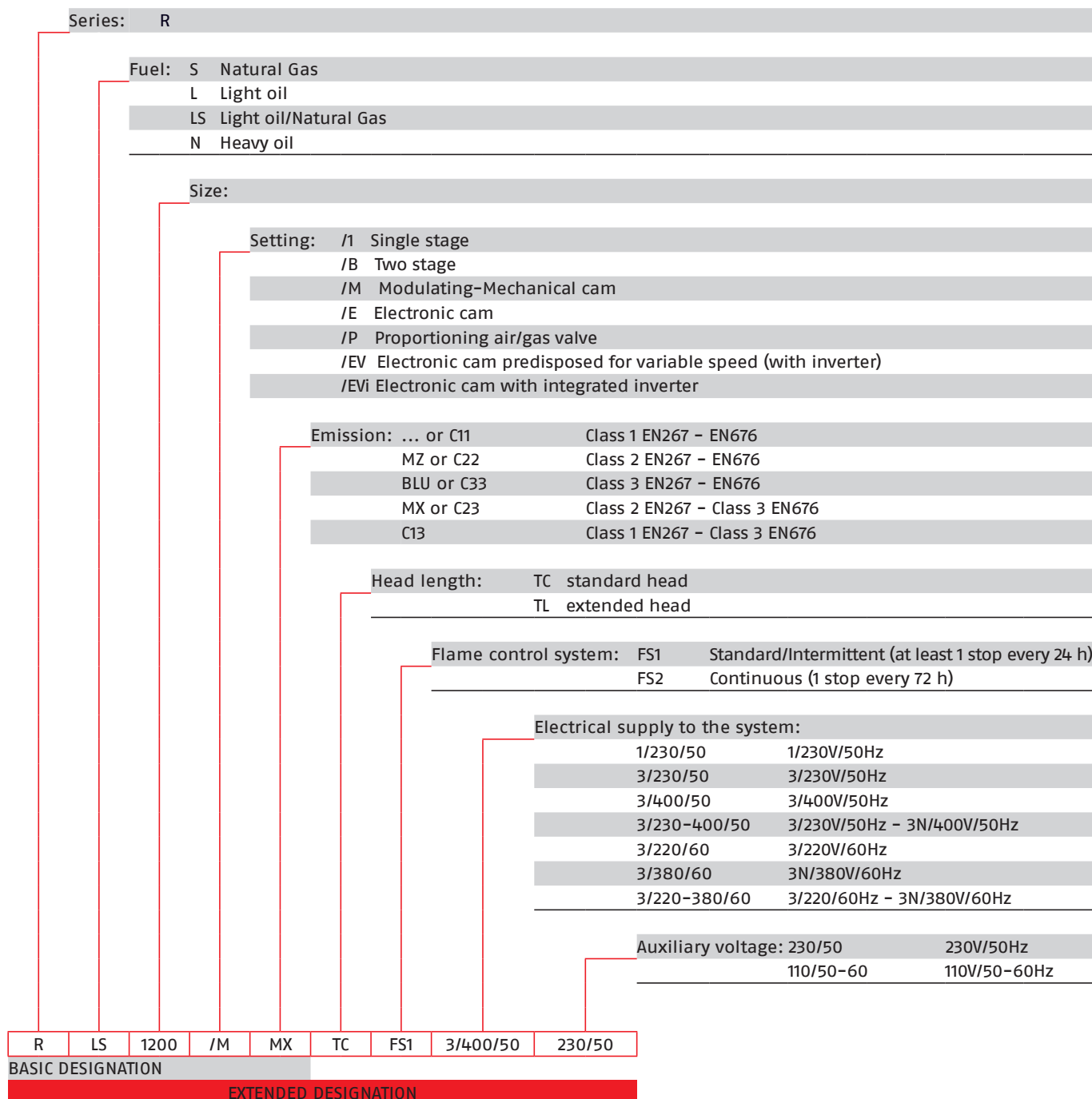

LOW NOx DUAL FUEL

Low NOx Modulating Dual Fuel Burners

RLS 800÷1200/M MX SERIES

Specification

STATE OF SUPPLY

Monoblock forced draught dual fuel burner with modulating operation, fully automatic, made up of:

- High performance fan
- Air suction circuit lined with sound-proofing material
- Air damper for air setting controlled by a high precision servomotor
- Air pressure switch
- Fan starting motor at 2800 rpm, three-phase, 400V, 50Hz
- Low emission combustion head, that can be set on the basis of required output, fitted with:
 - stainless steel end cone, resistant to corrosion and high temperatures
 - ignition electrodes
 - ignition by gas pilot with gas train for RLS 800 - 1000 - 1200 models
 - flame stability disk
- Mechanical cam with gas and oil modulator
- Maximum gas pressure switch, with pressure test point, to stop the burner in the case of over pressure on the fuel supply line
- Flame control panel for controlling the system safety - Infrared flame detector
- Star/delta starter for the fan motor - Main electrical supply terminal board
- Burner on/off switch
- Auxiliary voltage led signal
- Burner working led signal
- Contacts motor and thermal relay with release button
- Motor internal thermal protection
- Motor failure led signal
- Burner failure led signal and lighted release button
- Emergency button
- Coded connection plugs-sockets
- Burner opening hinge
- Lifting rings
- IP 54 electric protection level
- Light oil gears pump for high pressure fuel supply
- Dedicated pump starting motor
- Valve unit with double oil safety valve on the output circuit and double safety valve on the return circuit
- Maximum an minimum oil pressure switches
- Oil pressure gauges on supply and return oil lines
- Oil/Gas selector
- Flame inspection window.
- The gas train can only enter from the left side of the burner (fan motor side)
- The RLS 1000-1200/M dual fuel burners are equipped with as spray lance for light oil, activated by compressed air.

Standard equipment:

- 1 flange gasket
- 4 screws for fixing the flange
- 1 thermal screen
- 4 screws for fixing the burner flange to the boiler
- 2 flexible pipes for connection to the oil supply network
- 2 nipples for connection to the pump with gaskets
- Seal control pressure switch (for installation on gas train)
- Instruction handbook for installation, use and maintenance
- Spare parts catalogue.

RLS 800÷1200/M MX SERIES

Available models

Burners

CODE	MODEL	HEAT OUTPUT			TOTAL ELECTRICAL POWER (kW)	CERTIFICATION
		(kW)	LIGHT OIL (kg/h)	NATURAL GAS (Nm ³ /h)		
20147802	RLS 800/M MX TC FS1 3/400/50 230/50-60	1750/3500-8000	148/295-675	175/350-800	25,8 (oil) 24 (gas)	CE-0085CLO422
20147815	RLS 1000/M MX TC FS1 3/400/50 230/50-60	1200/3750-10600	110/320-793	130/380-940	27 (oil) 24 (gas)	CE-0085CN0119
20147814	RLS 1200/M MX TC FS1 3/400/50 230/50-60	1500/5500-11500	126/464-970	150/550-1150	32 (oil) 27,2 (gas)	CE-0085CN0120

Net calorific value light oil: 11,8 kWh/kg; 10.200 kcal/kg - Viscosity at 20°C: 4-6 mm²/s (cSt).

Net calorific value G20 gas: 10 kWh/Nm³; 8.600 kcal/Nm³ - Density: 0,71 kg/Nm³.

The burners of RLS/M MX series are in according to 2016/426/EU - 2014/30/EU - 2014/35/EU - 2014/68/EU - 2006/42 CE Directive and EN 267 - 676 Norm.

Due to the improvement of the technical specification of some products, some burner codes have been changed. The table below summarizes the correspondence between the previous and the new code.

MODEL					NEW CODE		OLD CODE	
RLS 800/M MX	TC	FS1	3/400/50	230/50-60	20147802 (1)	3911112 (2)		
RLS 1000/M MX	TC	FS1	3/400/50	230/50-60	20147815 (1)	20057525 (2)		
RLS 1200/M MX	TC	FS1	3/400/50	230/50-60	20147814 (1)	20053012 (2)		

Net calorific value light oil: 11,8 kWh/kg; 10.200 kcal/kg - Viscosity at 20°C: 4-6 mm²/s (cSt).

Net calorific value G20 gas: 10 kWh/Nm³; 8.600 kcal/Nm³ - Density: 0,71 kg/Nm³.

The burners of RLS/M series are in according to 2016/426/EU - 2014/30/EU - 2014/35/EU - 2006/42 CE Directive and EN 676 Norm.

(1) With RFGO control box.

(2) With LFL control box.

Gas Trains

CODE	GAS TRAIN MODEL				VPS CODE	ADAPTER CODE		
	MODEL	∅	C.T.			RLS 800	RLS 1000	RLS 1200
20137718*	VGD 50/1 - RT 122	Rp 2"	-	3010123+ 20186306	●	●	●	
20169190**	VGD 50/1 CT RT 122	Rp 2"	◆	◆	●	●	●	
20140762*	VGD 65/1 - FT 122	DN 65 (1)	-	3010123	□	●	●	
20169191**	VGD 65/1 CT FT 122	DN 65 (1)	◆	◆	□	●	●	
20140763*	VGD 80/1 - FT 122	DN 80	-	3010123		□		
20169192**	VGD 80/1 CT FT 122	DN 80	◆	◆		□		
20169193*	VGD 100/1 - FT 122	DN 100	-	3010123		3010370		
20169194**	VGD 100/1 CT FT 122	DN 100	◆	◆		3010370		
20169195*	VGD 125/1 - FT 122	DN 125	-	3010123		3010224		
20169196**	VGD 125/1 CT FT 122	DN 125	◆	◆		3010224		

Please see designation of Gas Train Series in the page before the Catalogue index.

* 230V/50Hz - 220V/60Hz electrical supply.

** 230V/50Hz electrical supply.

The valve seal control device is compulsory (conforming to EN 676) on gas trains to burners with a maximum output over 1200 kW.

To select the gas train please refer to the technical data leaflet and/or instruction manual.

(1) ∅in = DN 65, ∅out = DN 80.

C.T. Gas valve leak detection control device:

◆ gas train not equipped with leak detection control device; this device can be ordered separately - see VPS column - and installed later.

● gas train equipped with leak detection control device.

VPS Valve leak detection control device. Supplied separately from the gas train (please see Gas train accessories paragraph for both 50 Hz and 60 Hz codes).

● Not available.

□ Additional adapter not necessary, the gas train may be connected directly to the burner.

Low NOx Modulating Dual Fuel Burners

RLS 800÷1200/M MX SERIES

Burner accessories

Nozzles

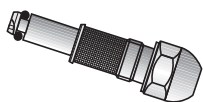

Return nozzles without needle are used on RLS/M MX burners. The nozzle must be ordered as accessory. The following table shows the features and codes on the basis of the maximum required fuel output.

BURNER	NOZZLE TYPE	RATED DELIVERY (kg/h)	NOZZLE CODE
▶ RLS 800/M MX	B5 SA 45°	375	3009332
▶ RLS 800/M MX	B5 SA 45°	550	3009346
▶ RLS 800/M MX	B5 SA 45°	650	3009352
▶ RLS 800/M MX	B5 SA 45°	750	3009356
▶ RLS 1000/M MX	B5 AA 60°	350	20047954
▶ RLS 1000/M MX	B5 AA 60°	600	20047978
▶ RLS 1000/M MX	B5 AA 60°	750	20047985
▶ RLS 1000/M MX	B5 AA 60°	900	20047994
▶ RLS 1200/M MX	CT5 60°	700	20006479
▶ RLS 1200/M MX	CT5 60°	700	20006479
▶ RLS 1200/M MX	CT5 60°	900	20006482
▶ RLS 1200/M MX	CT5 60°	1100	20006484

For more information please contact Riello Burners Commercial and Technical Department, our Application Engineers will be pleased to help you.

Accessories for modulating operation

POWER CONTROLLER



To obtain modulating operation, the RLS/M MX series of burners requires a regulator. For remote setpoint use RWF 55.

BURNER	TYPE	KIT CODE
▶ All models	RWF 50.2	20101190
▶ All models	RWF 55.5	20101191

PROBE



The relative temperature or pressure probes fitted to the regulator, must be chosen on the basis of the application.

BURNER	PROBE TYPE	RANGE (°C) (bar)	KIT CODE
▶ All models	Temperature PT 100	-100 ÷ 500°C	3010110
▶ All models	Pressure 4 ÷ 20 mA	0 ÷ 2,5 bar	3010213
▶ All models	Pressure 4 ÷ 20 mA	0 ÷ 16 bar	3010214
▶ All models	Pressure 4 ÷ 20 mA	0 ÷ 25 bar	3090873

RLS 800÷1200/M MX SERIES

Burner accessories

ANALOG CONTROL SIGNAL CONVERTER



BURNER	TYPE (INPUT SIGNAL)	KIT CODE
► All models	0/2 - 10 V (impedance 200 K Ω) 0/4 - 20 mA (impedance 250 Ω)	3010390

POTENTIOMETER



BURNER	KIT CODE
► RLS 800/M	3010402
► RLS 1000-1200/M	-

It is necessary for analogic control signal converter operation.

Fuel remote selection kit



BURNER	KIT CODE
► RLS 800/M	3010372

Sound proofing box

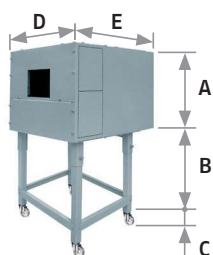

If noise emission needs reducing even further, sound-proofing boxes are available. When a lower "B" dimension is required, it is available the Box Support Kit code 20065135 which allows to reduce it at the fixed dimension of 55 mm. The sound-proofing boxes are not suitable for outdoor use.

BURNER	BOX TYPE	A (mm)	B (mm) min-max	C (mm)	D (mm)	E (mm)	[dB(A)] (*)	BOX CODE
► RLS 800/M	C7	1255	160 - 980	110	1140	1345	10	3010376
► RLS 1000-1200/M	C8	1425	285 - 1000	110	1500	1800	10	3010401

(*) Average noise reduction according to EN 15036-1 standard

Spacer kit



If burner head penetration into the combustion chamber needs reducing, varying thickness spacers are available, as given in the following table:

BURNER	SPACER THICKNESS S (mm)	KIT CODE
► RLS 800/M	180	20008903

Low NOx Modulating Dual Fuel Burners

RLS 800÷1200/M MX SERIES

Burner accessories

Continuous ventilation kit





If the burner requires continuous ventilation in the stages without flame, a special kit is available as given in the following table:

BURNER	KIT CODE
► RLS 1000-1200/M	20086519

Gas train accessories

Adapters

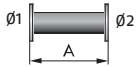
In certain cases, an adapter must be fitted between the gas train and the burner, when the diameter of the gas train is different from the set diameter of the burner. Below are given the available adapters; please see on the Gas Train list the correct adapter codes to select.

ADAPTER	DIMENSIONS			ADAPTER CODE
	$\varnothing i$ DN	$\varnothing O$ DN	A mm	
	125	80	320	3010224
	100	80	50	3010370

RLS 800÷1200/M MX SERIES

Gas train accessories

Stabiliser spring



To vary the pressure range of the gas train stabilisers, accessory springs are available. The following table shows these accessories with their application range. Please refer to the technical manual for the correct choice of spring.

GAS TRAIN	SPRING COLOUR	SPRING PRESSURE RANGE mbar	SPRING CODE
▶ VGD/1 series	Neutral	0 – 22	20181839
	Yellow	15 – 120	20141900
	Red	100 – 250	20141901

Seal control kit



To test the valve seals on the gas train, a special “seal control kit” is available. The valve seal control device is compulsory (EN 676) on gas trains to burners with a maximum output over 1200 kW. The seal control is type VPS 504.

GAS TRAIN	KIT CODE for 50 Hz operation	KIT CODE for 60 Hz operation
▶ VGD 50/1	3010123+20186306	20050030+20186306
▶ VGD 65/1 – 80/1 – 100/1 – 125/1	3010123	20050030