

RLS SERIES

The RLS series of burners covers a firing range from 163 to 1395 kW, and it has been designed for use in low or medium temperature hot water boilers, hot air or steam generators, diathermic oil boilers.

Operation is "two stage"; the burners are fitted with an electronic device LED PANEL, which supplies a diagnostic of burner status. Optimisation of sound emissions is guaranteed by the use of fans with reverse curve blades and sound deadening material incorporated in the air suction circuit. The elevated performance of the fans and combustion head guarantee flexibility of use and excellent working at all firing rates.

The exclusive design ensures reduced dimensions, simple use and maintenance. A wide range of accessories guarantees elevated working flexibility.



RLS 28	100/163 ÷	325 kW
RLS 38	116/232 ÷	442 kW
RLS 50	145/290 ÷	581 kW
RLS 70	232/465 ÷	814 kW
RLS 100	349/698 ÷	1163 kW
RLS 130	465/930 ÷	1395 kW

FIRING RATES

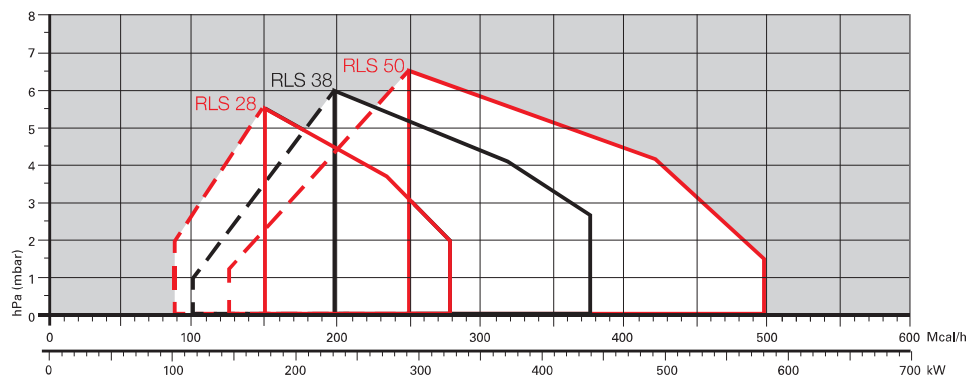

Useful working field for choosing the burner

Modulation range

Test conditions conforming to EN267- EN676
 Temperature: 20°C
 Pressure: 1013,5 mbar
 Altitude: 0 m a.s.l.

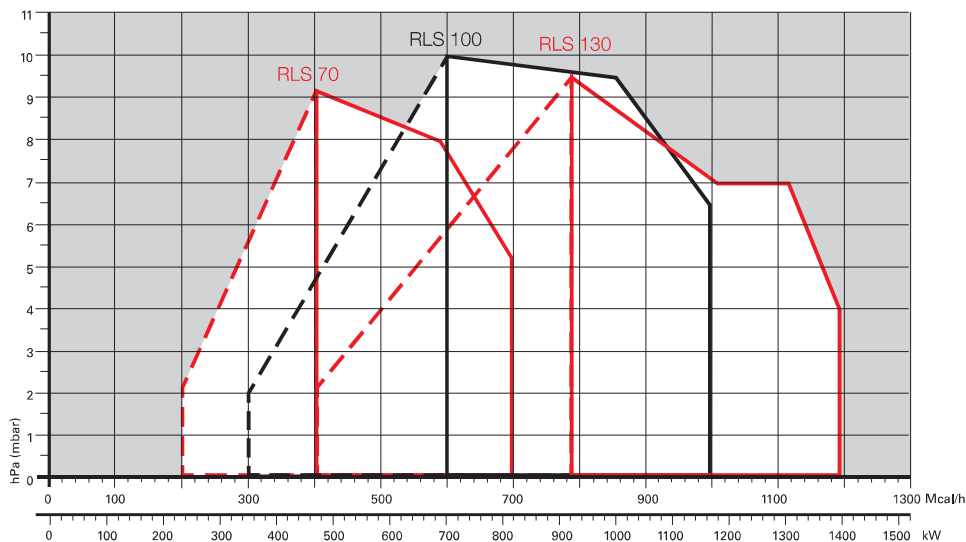

Two Stage Dual Fuel Burners

RLS SERIES

Overall dimensions (mm)

BURNER

RLS 28 - 38 - 50

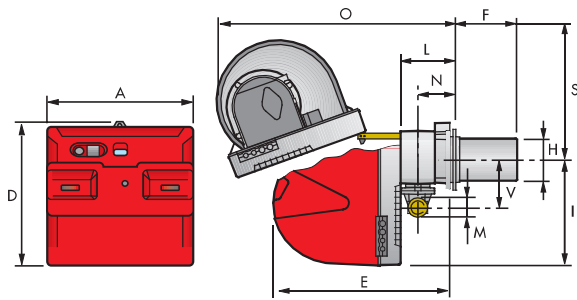

RLS 70 - 100 - 130

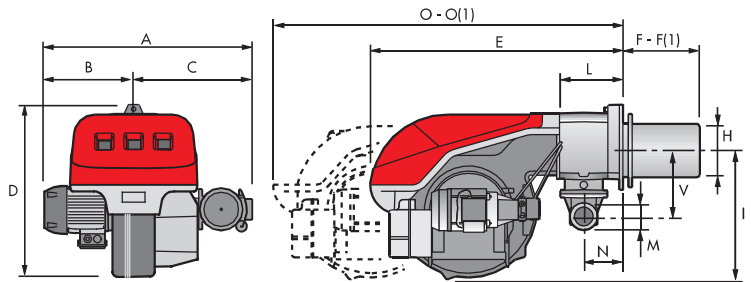

MODEL	A	B	C	D	E	F - F(1)	H	I	L	M	N	O - O(1)	S	V
▶ RLS 28	476	-	-	474	580	191 - 326	140	352	164	1 1/2"	108	810 - 810	367	168
▶ RLS 38	476	-	-	474	580	201 - 336	152	352	164	1 1/2"	108	810 - 810	367	168
▶ RLS 50	476	-	-	474	580	216 - 351	152	352	164	1 1/2"	108	810 - 810	367	168
▶ RLS 70	691	296	395	555	840	250 - 385	179	430	214	2"	134	1161 - 1361	-	221
▶ RLS 100	707	312	395	555	840	250 - 385	189	430	214	2"	134	1161 - 1361	-	221
▶ RLS 130	733	338	395	555	840	250 - 385	189	430	214	2"	134	1161 - 1361	-	221

(1) Length with extended combustion head

BURNER - BOILER MOUNTING FLANGE

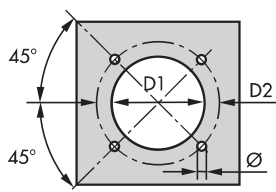

MODEL	D1	D2	Ø
▶ RLS 28	160	224	M8
▶ RLS 38	160	224	M8
▶ RLS 50	160	224	M8
▶ RLS 70	185	275-325	M12
▶ RLS 100	195	275-325	M12
▶ RLS 130	195	275-325	M12

PACKAGING

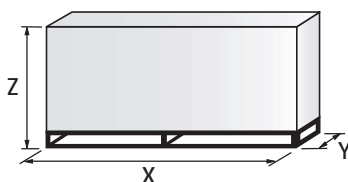

MODEL	X	Y	Z	kg
▶ RLS 28	1190	492	510	43
▶ RLS 38	1190	492	510	45
▶ RLS 50	1190	492	510	46
▶ RLS 70	1405	1000	660	70
▶ RLS 100	1405	1000	660	73
▶ RLS 130	1405	1000	660	76

Specification

DESIGNATION OF SERIES

Series: R									
Fuel: S Natural Gas									
L Light oil									
LS Light oil/Natural Gas									
N Heavy oil									
Size:									
Setting: /1 Single stage									
/B Two stage									
/M Modulating-Mechanical cam									
/E Electronic cam									
/P Proportioning air/gas valve									
/EV Electronic cam predisposed for variable speed (with inverter)									
/EVi Electronic cam with integrated inverter									
Emission: ... or C11 Class 1 EN267 - EN676									
MZ or C22 Class 2 EN267 - EN676									
BLU or C33 Class 3 EN267 - EN676									
MX or C23 Class 2 EN267 - Class 3 EN676									
C13 Class 1 EN267 - Class 3 EN676									
Head length: TC standard head									
TL extended head									
Flame control system: FS1 Standard/Intermittent (at least 1 stop every 24 h)									
FS2 Continuous (1 stop every 72 h)									
Electrical supply to the system:									
1/230/50 1/230V/50Hz									
3/230/50 3/230V/50Hz									
3/400/50 3/400V/50Hz									
3/230-400/50 3/230V/50Hz - 3N/400V/50Hz									
3/220/60 3/220V/60Hz									
3/380/60 3N/380V/60Hz									
3/220-380/60 3/220/60Hz - 3N/380V/60Hz									
Auxiliary voltage: 230/50 230V/50Hz									
110/50-60 110V/50-60Hz									
R	LS	28			TC	FS1	3/400/50	230/50	
BASIC DESIGNATION					EXTENDED DESIGNATION				

DUAL FUEL

Two Stage Dual Fuel Burners

RLS SERIES

Specification

STATE OF SUPPLY

Monobloc forced draught dual fuel burner, two stage operation, made up of:

- Air suction circuit lined with sound-proofing material
- Fan with reverse curve blades
- Fan starting motor
- Air damper for air setting controlled by a servomotor
- Minimum air pressure switch
- Combustion head, that can be set on the basis of required output
- Gears pump for high pressure fuel supply
- Pump starting motor
- Oil safety valves
- Two oil valves (1st and 2nd stage)
- Burner safety control box
- Electronic device to check all burners operational modes (Led Panel)
- UV photocell for flame detection
- Burner on/off switch
- Oil/Gas selector
- Manual 1st and 2nd stage switch
- Plugs for electrical connections (RLS 28-38-50)
- Flame inspection window
- Slide bars for easier installation and maintenance
- Protection filter against radio interference
- IP 44 electric protection level.

Standard equipment:

- 1 gas train flange
- 1 flange gasket
- 4 screws for fixing the flange
- 1 thermal screen
- 4 screws for fixing the burner flange to the boiler
- 2 flexible pipes for connection to the oil supply network
- 2 nipples for connection to the pump with gaskets
- Kit for transformation to LPG
- Fairleads for electrical connections (for RLS 28-38-50 model)
- Instruction handbook for installation, use and maintenance
- Spare parts catalogue.

Available models

Burners

CODE	MODEL		HEAT OUTPUT			TOTAL ELECTRICAL POWER (kW)	CERTIFICATION
			(kW)	LIGHT OIL (kg/h)	NATURAL GAS (Nm ³ /h)		
20147897	RLS 28 TC LPFS1 1/230/50	230/50	100/163-325	8,5/13,7-27,4	10/16-33	0,53	CE-0085CT0269
20159362	RLS 28 TC LPFS1 1/220/60	220/60	100/163-325	8,5/13,7-27,4	10/16-33	0,53	-
20148815	RLS 28 TL LP FS1 1/230/50	230/50	100/163-325	8,5/13,7-27,4	10/16-33	0,53	CE-0085CT0269
20147803	RLS 38 TC LPFS1 1/230/50	230/50	116/232-442	9,8/19,6-37,3	12/23-44	0,76	CE-0085CT0269
20148817	RLS 38 TL LP FS1 1/230/50	230/50	116/232-442	9,8/19,6-37,3	12/23-44	0,76	CE-0085CT0269
20147805	RLS 50 TC LPFS1 3/230-400/50	230/50	145/290-581	12,3/24,5-49	15/29-58	0,91	CE-0085CT0269
20159364	RLS 50 TC LPFS1 3/220-380/60	220/60	145/290-581	12,3/24,5-49	15/29-58	0,91	-
20148818	RLS 50 TL LP FS1 3/230-400/50	230/50	145/290-581	12,3/24,5-49	15/29-58	0,91	CE-0085CT0269

RLS SERIES

Available models

Burners

CODE	MODEL	HEAT OUTPUT			TOTAL ELECTRICAL POWER (kW)	CERTIFICATION
		(kW)	LIGHT OIL (kg/h)	NATURAL GAS (Nm ³ /h)		
20147798	RLS 70 TC LP FS1 3/230-400/50 230/50	232/465-814	19/39-69	23/47-81	2,0	CE-0085CT0269
20159363	RLS 70 TC LP FS1 3/208-230/380/60 230/50-60	232/465-814	19/39-69	23/47-81	2,0	-
20149563	RLS 70 TL LP FS1 3/230-400/50 230/50	232/465-814	19/39-69	23/47-81	2,0	CE-0085CT0269
20147799	RLS 100 TC LP FS1 3/230-400/50 230/50	349/698-1163	29,5/59-98	35/70-116	2,4	CE-0085CT0269
20159369	RLS 100 TC LP FS1 3/220/60 230/50	349/698-1163	29,5/59-98	35/70-116	2,5	-
20159366	RLS 100 TC LP FS1 3/208-230/380/60 230/50-60	349/698-1163	29,5/59-98	35/70-116	2,7	-
20149565	RLS 100 TL LP FS1 3/230-400/50 230/50	349/698-1163	29,5/59-98	35/70-116	2,4	CE-0085CT0269
20147800	RLS 130 TC LP FS1 3/230-400/50 230/50	465/930-1395	39/78-118	47/93-140	3,2	CE-0085CT0269
20169069	RLS 130 TC LP FS1 3/208-230/380/60 230/50-60	465/930-1395	39/78-118	47/93-140	3,2	-
20148028	RLS 130 TL LP FS1 3/230-400/50 230/50	465/930-1395	39/78-118	47/93-140	3,2	CE-0085CT0269

Net calorific value light oil: 11,8 kWh/kg; 10.200 kcal/kg - Viscosity at 20°C: 4-6 mm²/s (cSt).

Net calorific value G20 gas: 10 kWh/Nm³; 8.600 kcal/Nm³ - Density: 0,71 kg/Nm³.

The burners of RLS series are in according to 2014/30/EU - 2014/35/EU - 2016/426/EU - 2006/42 CE Directive and EN 267 - 676 Norm.

Due to the improvement of the technical specification of some products, some burner codes have been changed. The table below summarizes the correspondence between the previous and the new code.

MODEL	NEW CODE	OLD CODE
RLS 28 TC LP FS1 1/230/50 230/50	20147897 (1)	3483201 (2)
RLS 28 TC LP FS1 1/220/60 220/60	20159362 (1)	20008836 (2)
RLS 28 TL LP FS1 1/230/50 230/50	20148815 (1)	20052632 (2)
RLS 38 TC LP FS1 1/230/50 230/50	20147803 (1)	3484101 (2)
RLS 38 TL LP FS1 1/230/50 230/50	20148817 (1)	20052633 (2)
RLS 50 TC LP FS1 3/230-400/50 230/50	20147805 (1)	3484601 (2)
RLS 50 TC LP FS1 3/220-380/60 220/60	20159364 (1)	20008911 (2)
RLS 50 TL LP FS1 3/230-400/50 230/50	20148818 (1)	20052634 (2)
RLS 70 TC LP FS1 3/230-400/50 230/50	20147798 (1)	3485001 (2)
RLS 70 TC LP FS1 3/208-230/380/60 230/50-60	20159363 (1)	3091489 (2)
RLS 70 TL LP FS1 3/230-400/50 230/50	20149563 (1)	20052635 (2)
RLS 100 TC LP FS1 3/230-400/50 230/50	20147799 (1)	3485201 (2)
RLS 100 TC LP FS1 3/220/60 230/50	20159369 (1)	3091842 (2)
RLS 100 TC LP FS1 3/208-230/380/60 230/50-60	20159366 (1)	3091589 (2)
RLS 100 TL LP FS1 3/230-400/50 230/50	20149565 (1)	20052636 (2)
RLS 130 TC LP FS1 3/230-400/50 230/50	20147800 (1)	3485401 (2)
RLS 130 TC LP FS1 3/208-230/380/60 230/50-60	20169069 (1)	20019826 (2)
RLS 130 TL LP FS1 3/230-400/50 230/50	20148028 (1)	20052638 (2)

(1) With RFGO control box

(2) With LFL control box

Net calorific value light oil: 11,8 kWh/kg; 10.200 kcal/kg - Viscosity at 20°C: 4-6 mm²/s (cSt).

Net calorific value G20 gas: 10 kWh/Nm³; 8.600 kcal/Nm³ - Density: 0,71 kg/Nm³.

The burners of RLS series are in according to 2014/30/EU - 2014/35/EU - 2016/426/EU - 2006/42 CE Directive and EN 267 - 676 Norm.

Two Stage Dual Fuel Burners

RLS SERIES

Available models

Gas Trains

CODE	GAS TRAIN			VPS CODE	ADAPTER CODE			
	MODEL	Ø	C.T.		RLS 28	RLS 38-50	RLS 70	RLS 100-130
3970084*	MB 405/2 - RSD 20	Rp 1/2"	-	3010123	20044756		●	●
3970537*	MB 407/2 - RSD 20	Rp 3/4"	-	3010123			●	●
3970556*	MB 407/2 - RT 20	Rp 3/4"	-	3010123			●	●
3970534*	MB 410/2 - RSD 20	Rp 3/4"	-	3010123	3000824		3000824+	●
3970557*	MB 410/2 - RT 20	Rp 3/4"	-	3010123			3000843	●
3970152*	MB 412/2 - RT 20	Rp 1" 1/2	-	3010123	□	□	3000843	
3970183*	MB 415/2 - RT 20	Rp 1" 1/2	-	3010123	□	□		
3970184*	MB 420/2 - RT 20	Rp 2"	-	3010123	3000822		□	□
3970185**	MB 420/2 CT RT 20	Rp 2"	◆	◆			□	□
3970153*	CB 512/2 - RT 32	Rp 1" 1/2	-	3010125	□	□	3000843	
3970154*	CB 520/2 - RT 32	Rp 2"	-	3010125	3000822		□	□
3970155*	CB 5065/2 - FT 32	DN 65	-	3010125	●	3000825		
3970167**	CB 5065/2 CT FT 32	DN 65	◆	◆	●			
3970156*	CB 5080/2 - FT 32	DN 80	-	3010125	●	●	3000826	
3970168**	CB 5080/2 CT FT 32	DN 80	◆	◆	●	●		

Please see designation of Gas Train Series in the page before the Catalogue index.

* 230V/50Hz -220V/60Hz electrical supply.

** 230V/50Hz electrical supply.

The valve seal control device is compulsory (conforming to EN 676) on gas trains to burners with a maximum output over 1200 kW.

To select the gas train please refer to the technical data leaflet and/or instruction manual.

C.T. Gas valve leak detection control device:

- gas train not equipped with leak detection control device; this device can be ordered separately - see VPS column - and installed later.

◆ gas train equipped with leak detection control device.

VPS Valve leak detection control device. Supplied separately from the gas train (please see Gas train accessories paragraph for both 50 Hz and 60 Hz codes).

● Not available.

□ Additional adapter not necessary, the gas train may be connected directly to the burner.

RLS SERIES

Burner accessories

Nozzles type 60° B



The nozzles must be ordered separately. The following table shows the features and codes on the basis of the maximum required fuel output.

NOTE: each burner needs N° 2 nozzles.

BURNER	RATED DELIVERY (kg/h) at 12 bar	GPH	NOZZLE CODE
▶ RLS 28	8,5	2,00	3042126
▶ RLS 28-38	10,6	2,50	3042140
▶ RLS 28-38-50	12,7	3,00	3042158
▶ RLS 28-38-50	14,8	3,50	3042162
▶ RLS 38-50	17	4,00	3042172
▶ RLS 38-50	19,1	4,50	3042182
▶ RLS 38-50-70	21,2	5,00	3042192
▶ RLS 50-70	23,3	5,50	3042202
▶ RLS 50-70	25,5	6,00	3042212
▶ RLS 50-70	27,6	6,50	3042222
▶ RLS 70-100	29,7	7,00	3042232
▶ RLS 70-100	31,8	7,50	3042242
▶ RLS 70-100	33,9	8,00	3042252
▶ RLS 70-100	36,1	8,50	3042262
▶ RLS 70-100-130	40,3	9,50	3042282
▶ RLS 70-100-130	42,4	10,00	3042292
▶ RLS 70-100-130	46,7	11,00	3042312
▶ RLS 100-130	50,9	12,00	3042322
▶ RLS 100-130	55,1	13,00	3042332
▶ RLS 100-130	59,4	14,00	3042352
▶ RLS 100-130	63,6	15,00	3042362
▶ RLS 100-130	67,9	16,00	3042382
▶ RLS 130	72,1	17,00	3042392

LPG kit

For burning LPG gas, a dedicated kit is available with RLS dual fuel burners as standard equipment, if necessary it is available also as accessory as given in the following table:

BURNER	KIT CODE FOR "STANDARD HEAD"	KIT CODE FOR "EXTENDED HEAD"
▶ RLS 28 - 38 - 50	3010304	3010304
▶ RLS 70 - 100 - 130	3010305	3010305

Two Stage Dual Fuel Burners

RLS SERIES

Burner accessories

Extended head kit

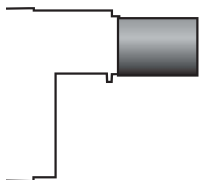

“Standard head” burners can be transformed into “extended head” versions, by using the special kit. The kits available for the various burners, giving the original and the extended lengths, are listed below.

BURNER	STANDARD HEAD LENGTH (mm)	EXTENDED HEAD LENGTH (mm)	KIT CODE
▶ RLS 28	191	326	20097840
▶ RLS 38	201	336	20097868
▶ RLS 50	216	351	20097869
▶ RLS 70	250	385	3010345
▶ RLS 100	250	385	3010346
▶ RLS 130	250	385	3010347

Degasing unit



To solve problem of air in the oil sucked, two versions of degassing unit are available.

BURNER	FILTER	FILTERING DEGREE (µm)	DEGASING UNIT CODE (*)
▶ RLS 28 - 38 - 50 ▶ RLS 70 - 100	With filter	50 - 75	3010055

(*) Max capability 80 kg/h (more filters are needed for higher flow).

Gas max pressure switch kit

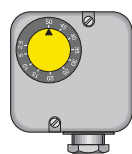

If necessary a Gas max pressure Switch kit is available.

BURNER	KIT CODE
▶ RLS 28 - 38 - 50 - 70 - 100 - 130	3010493

Ground fault interrupter kit



A “Ground fault interrupter kit” is available as a safety device for electrical system fault.

BURNER	KIT CODE
▶ RLS 28-38-50	3010321
▶ RLS 70-100-130	20098337

Burner accessories

Connection flange kit

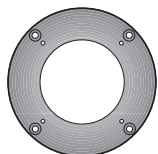

A kit is available for use where the burner opening on the boiler is of excessive diameter.

BURNER	KIT CODE
► RLS 28 - 38 - 50	3010138

Continuous ventilation kit



If the burner requires continuous ventilation in the stages without flame, a special kit is available as given in the following table.

BURNER	KIT CODE
► All models	3010094

Sound proofing box

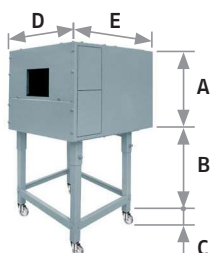

If noise emission needs reducing even further, sound-proofing boxes are available. When a lower "B" dimension is required, it is available the Box Support Kit code 20065135 which allows to reduce it at the fixed dimension of 55 mm. The sound-proofing boxes are not suitable for outdoor use.

BURNER	BOX TYPE	A (mm)	B (mm) min-max	C (mm)	D (mm)	E (mm)	[dB(A)] (*)	BOX CODE
► RLS 28 - 38 - 50	C1/3	650	372 - 980	110	690	770	10	3010403
► RLS 70 - 100 - 130	C4/5	850	160 - 980	110	980	930	10	3010404

(*) Average noise reduction according to EN 15036-1 standard

Gas train accessories

Seal control kit



To test the valve seals on the gas train, a special "seal control kit" is available.

BURNER	GAS TRAIN	KIT CODE for 50 Hz operation	KIT CODE for 60 Hz operation
► All models	MB/2 Series	3010123	20050030
	CB/2 Series	3010125	On demand

Two Stage Dual Fuel Burners

RLS SERIES

Gas train accessories

Stabiliser spring









Accessory springs are available to vary the pressure range of the gas train stabilisers.

GAS TRAIN	SPRING COLOUR	SPRING PRESSURE RANGE mbar	SPRING CODE
▶ CB 512/2	Red	25 - 55	3010131
	Black	60 - 110	3010157
	Pink	90 - 150	3090486
▶ CB 520/2	Red	25 - 55	3010132
	Black	60 - 110	3010158
	Pink	100 - 150	3090487
▶ CB 5065/2 - 5080/2	Red	25 - 55	3010133
	Black	60 - 110	3010135
	Pink	100 - 150	3090456
	Grey	140 - 200	3090992

Adapters

In certain cases, an adapter must be fitted between the gas train and the burner, when the diameter of the gas train is different from the set diameter of the burner. Below are given the available adapters; please see on the Gas Train list the correct adapter codes to select.

ADAPTER	LENGTH mm	ADAPTER CODE
 2" 1 1/2"	70	3000822
 3/4" 1 1/2"	31	3000824
 DN 65 2" 1/2 2"	300	3000825
 2" 1/2 1 1/2"		
 DN 80 2" 1/2 2"	300	3000826
 1" 1/2 2"	35	3000843
 1/2" 1 1/2"	31	20044756