

GB Gas oil burner

Two-stage operation



RL B10

CODE	MODEL	TYPE
20032719	RL 190	673 T1

1	Declaration	3
2	Information and general warnings	4
2.1	Information about the instruction manual	4
2.1.1	Introduction	4
2.1.2	General dangers	4
2.1.3	Danger: live components	4
2.2	Guarantee and responsibility	5
2.3	Guidance for the use of bio fuel blends up to 10%	5
2.3.1	Information and general instructions	6
2.3.2	Product Disclaimer Statement	6
3	Safety and prevention	7
3.1	Introduction	7
3.2	Safety warnings	7
3.3	Basic safety rules	7
3.4	Personnel training	7
4	Technical description of the burner	8
4.1	Burner designation	8
4.2	Models available	8
4.3	Technical data	9
4.4	Packaging - Weight	10
4.5	Overall dimensions	10
4.6	Firing rate	10
4.6.1	Test boiler	10
4.7	Burner description	11
4.8	Standard equipment	11
5	Installation	12
5.1	Notes on safety for the installation	12
5.2	Handling	12
5.3	Preliminary checks	12
5.4	Installer/Service notes for the use of Gas oil with Bio blends up to 10%	13
5.5	Operating position	13
5.6	Boiler plate	13
5.7	Blast tube length	14
5.8	Securing the burner to the boiler	14
5.9	Nozzle installation	14
5.9.1	Choice of nozzles for 1st and 2nd stage	14
5.9.2	Nozzle assembly	15
5.10	Gas oil supply	16
5.10.1	Double-pipe circuit	16
5.10.2	The loop circuit	16
5.10.3	Single-pipe circuit	17
5.11	Hydraulic connections	17
5.12	Pump	18
5.12.1	Technical data	18
5.12.2	Pump priming	18
6	Electrical system	19
6.1	Notes on safety for the electrical wiring	19
6.2	Electrical connections	19
6.3	Calibration of thermal relay	20
7	Start-up, calibration and operation of the burner	21
7.1	Notes on safety for the first start-up	21
7.2	Burner firing	21

7.3	Burner calibration	21
7.3.1	Combustion head setting	21
7.3.2	1st and 2nd stage nozzles	21
7.3.3	Pump pressure	22
7.3.4	1st stage fan air gate valve	22
7.3.5	2st stage fan air gate valve	22
7.4	Burner operation	23
7.4.1	Burner starting	23
7.4.2	Steady state operation	24
7.4.3	Firing failure	24
7.4.4	Undesired shutdown during operation	24
7.5	Final checks	24
8	Maintenance	25
8.1	Notes on safety for the maintenance	25
8.2	Maintenance programme	25
8.2.1	Maintenance frequency.....	25
8.2.2	Checking and cleaning.....	25
8.3	Opening the burner	26
8.4	Closing the burner.....	26
8.5	Burner start-up cycle diagnostics	27
8.6	Resetting the control box and using diagnostics.....	27
8.6.1	Resetting the control box	27
8.6.2	Visual diagnostics	27
8.6.3	Software diagnostics	27
9	Faults - Possible causes - Solutions.....	28
A	Appendix - Accessories (optional).....	30
B	Appendix - Electrical panel layout.....	32

1 Declaration

Declaration of conformity in accordance with ISO / IEC 17050-1

Manufacturer:	RIELLO S.p.A.		
Address:	Via Pilade Riello, 7 37045 Legnago (VR)		
Product:	Gas oil burner		
Model:	RL 190		
These products are in compliance with the following Technical Standards:			
EN 267			
EN 292			
and according to the European Directives:			
MD	2006/42/EC	Machine Directive	
LVD	2006/95/EC	Low Voltage Directive	
EMC	2004/108/EC	Electromagnetic Compatibility	

The quality is guaranteed by a quality and management system certified in accordance with UNI EN ISO 9001.

Manufacturer's Declaration

RIELLO S.p.A. declares that the following products comply with the NOx emission limits specified by German standard "1. BImSchV release 26.01.2010".

Product	Type	Model	Power
Gas oil burner	673 T1	RL 190	759 - 2443 kW

Legnago, 15.03.2010

Mr. G. Conticini
Burners Division Department
RIELLO S.p.A.



2 Information and general warnings

2.1 Information about the instruction manual

2.1.1 Introduction

The instruction manual supplied with the burner:

- is an integral and essential part of the product and must not be separated from it; it must therefore be kept carefully for any necessary consultation and must accompany the burner even if it is transferred to another owner or user, or to another system. If the manual is lost or damaged, another copy must be requested from the Technical Assistance Service of the area;
- is designed for use by qualified personnel;
- offers important indications and instructions relating to the installation safety, start-up, use and maintenance of the burner.

Symbols used in the manual

In some parts of the manual you will see triangular DANGER signs. Pay great attention to these, as they indicate a situation of potential danger.

2.1.2 General dangers

The **dangers** can be of **3 levels**, as indicated below.



Maximum danger level!
This symbol indicates operations which, if not carried out correctly, cause serious injury, death or long-term health risks.



This symbol indicates operations which, if not carried out correctly, may cause serious injury, death or long-term health risks.



This symbol indicates operations which, if not carried out correctly, may cause damage to the machine and/or injury to people.

2.1.3 Danger: live components



This symbol indicates operations which, if not carried out correctly, lead to electric shocks with lethal consequences.

Other symbols



ENVIRONMENTAL PROTECTION

This symbol gives indications for the use of the machine with respect for the environment.

- This symbol indicates a list.

Abbreviations used

Ch.	Chapter
Fig.	Figure
Page	Page
Sec.	Section
Tab.	Table

Delivery of the system and the instruction manual

When the system is delivered, it is important that:

- the instruction manual is delivered to the user by the system manufacturer, with the recommendation to keep it in the room where the heat generator is to be installed.
- The instruction manual shows:
 - the serial number of the burner;

.....

- the address and telephone number of the nearest Assistance Centre.

.....

- The system supplier must carefully inform the user about:
 - the use of the system;
 - any further tests that may be required before activating the system;
 - maintenance, and the need to have the system checked at least once a year by a representative of the manufacturer or another specialised technician.
To ensure a periodic check, the manufacturer recommends the drawing up of a Maintenance Contract.

2.2 Guarantee and responsibility

The manufacturer guarantees its new products from the installation date, in accordance with the regulations in force and/or the sales contract. At the moment of the first start-up, check that the burner is integral and complete.



Failure to observe the information given in this manual, operating negligence, incorrect installation and carrying out of non authorised modifications will result in the annulment by the manufacturer of the guarantee that it supplies with the burner.

In particular, the rights to the guarantee and the responsibility will no longer be valid, in the event of damage to things or injury to people, if such damage/injury was due to any of the following causes:

- incorrect installation, start-up, use and maintenance of the burner;
- improper, incorrect or unreasonable use of the burner;
- intervention of unqualified personnel;
- carrying out of unauthorised modifications on the equipment;
- use of the burner with safety devices that are faulty, incorrectly applied and/or not working;
- installation of untested supplementary components on the burner;
- powering of the burner with unsuitable fuels;
- faults in the fuel supply system;
- continuation of use of the burner when a fault has occurred
- repairs and/or overhauls incorrectly carried out;
- modification of the combustion chamber with inserts that prevent the regular development of the structurally established flame;
- insufficient and inappropriate surveillance and care of those burner components most likely to be subject to wear and tear;
- the use of non-original components, including spare parts, kits, accessories and optional;
- force majeure.

The manufacturer furthermore declines any and every responsibility for the failure to observe the contents of this manual.

Riello warranty is subject to correct burner, appliance and application matching, and set up in line with Riello's instructions and guidelines. All components within the hydraulic circuit suitable for bio fuel use and supplied by Riello will be identified as Bio compatible. No warranty is given in relation to the use of components which are not so identified with bio fuel blends. If in any doubt please contact Riello for further advice.

If any Riello burners are used with fuel with a bio content >10% then the components within the hydraulic circuit maybe affected and are not covered under warranty. The hydraulic circuit consists of;

- Pump
 - Hydraulic ram (where applicable)
 - Valve block
 - Flexible oil lines (considered as a consumable component)
1. Irrespective of any warranty given by Riello in relation to normal use and manufacturing defects, when fuels not meeting the relevant standards are used, or where fuel storage issues have not been addressed correctly, or the equipment used is not compatible, if failures occur which are directly or indirectly attributed to such issues and/or to the non-observance of this guidance, then no warranty or liability is implied or accepted by Riello.
 2. Riello have carefully chosen the specification of the bio compatible components including the flexible oil lines to protect the pump, safety valve and nozzle. The Riello warranty is dependent upon the use of Riello genuine components including the oil lines, being used.
 3. Riello warranty does not cover defects arising from incorrect commissioning or servicing by non Riello employed service engineers, and any issues impacting the burner arising from external site related issues.

2.3 Guidance for the use of bio fuel blends up to 10%

Background

With increasing focus on renewable and sustainable energy requirements, Bio fuel usage is set to increase. Riello is committed to promoting energy conservation and the use of renewable energy from sustainable resources including liquid bio fuels, however there are some technical aspects that must be considered at the planning stage of using such fuels to reduce the potential for equipment failure or the risks of fuel leakage.

Liquid Bio fuel is a generic description used for oil that can come from numerous feed stocks including recycled cooking oils. These types of oils have to be considered and treated differently from standard mineral or fossil fuels, as they are generally more acidic, hygroscopic and less stable.

Due to this, a holistic approach is needed from the specification of the liquid Bio fuel, the storage of the fuel, its oil supply line and ancillary equipment, and very importantly the oil filtration and the burner itself. The specification for FAME (Fatty Acids Methyl Ester) liquid Bio fuel is critical to reliable equipment operation.

It is a minimum requirement that the fuel blend (up to 10% Bio) is obtained with gasoil in accordance with the relevant EN standards, regional regulations and FAME in accordance with EN 14214. It is also important that the fuel blends meet the require-

ments related to operational environment conditions within the relevant EN standards.

When choosing your Riello oil products where you know Bio fuels will be in use, please make sure that a Bio compatible burner and/or components have been supplied. If an existing burner is to be used with a liquid Bio fuel then a kit may be required to make it compatible and the guidance notes enclosed concerning oil storage and filtration must be adhered to. The end user is responsible for the thorough verification of the potential risks associated with the introduction of a bio fuel blend and the suitability of the appliances and installation applicable.

Irrespective of any warranty given by Riello in relation to normal use and manufacturing defects, when fuels not meeting the relevant standards are used, or where fuel storage issues have not been addressed correctly, or the equipment used is not compatible, if failures occur which are directly or indirectly attributed to such issues and/or to the non-observance of this guidance, then no warranty or liability is implied or accepted by Riello.

2.3.1 Information and general instructions

To ensure consistency, the supplier of the fuel must be able to demonstrate compliance with a recognised Quality Control and management system to ensure high standards are maintained within the storage, blending and delivery processes. The installation oil storage tank and its ancillaries must also be prepared BEFORE liquid Bio fuel is introduced. Checks and preparation should include;

- For new installations, make sure that all materials and seals in the oil storage and supply line to the burner are compatible with Bio fuels. For all installations, there must be a good quality bio compatible oil filter at the tank and then a secondary filter of 100 Microns protecting the burner from contamination.
- If an existing oil storage tank is to be used then in addition to the materials checks as detailed above, it will be essential that the tank is first inspected for condition and checked for water or other contamination. Riello strongly recommends that the tank is cleaned and oil filters replaced prior to Bio fuel delivery. If this is not completed then due to the hydroscopic nature of Bio fuel, it will effectively clean the tank, absorb water present which in turn will result in equipment failure that is not covered by the manufacturer's warranty.
- Depending on the capacity of the oil storage tank and oil usage, fuels may remain static within the tank for some considerable time and so Riello recommends that the oil distributor is consulted regarding the use of additional Biocides within the fuel to prevent microbial growth from occurring within the tank. Riello suggests that fuel suppliers and or service companies are contacted for guidance on fuel filtration. Special attention should be applied to dual fuel applications where oil may be stored for long periods of time.
- The burner must be set according to the appliance application and commissioned checking that all combustion parameters are as recommended in the appliance technical manual.
- Riello recommends that the in line and burner oil pump filters are inspected and if required replaced at least every 4 months during burner use, before the burner start-up following a long period of discontinue operation and even more frequently where contamination has occurred. Particular attention is needed when inspecting and checking for fuel leakages from seals, gaskets and hoses.

2.3.2 Product Disclaimer Statement

CAREFULLY READ THE FOLLOWING DISCLAIMER. YOU ACCEPT AND AGREE TO BE BOUND BY THIS DISCLAIMER BY PURCHASING RIELLO BIO COMPATIBLE BURNERS AND/OR COMPONENTS.

Although the information and recommendations (hereinafter "Information") in this guidance is presented in good faith, believed to be correct and has been carefully checked, Riello (and its subsidiaries) makes no representations or warranties as to the completeness or accuracy of the Information. Information is supplied upon the condition that the persons receiving same will make their own determination as to its suitability for their purposes prior to use. In no event will Riello (and its subsidiaries) be responsible for damages of any nature whatsoever resulting from the use of or reliance upon Information.

Other than set forth herein, Riello (and its subsidiaries) makes no additional warranties with respect to the bio compatible burner, either express or implied, including that of merchantability or fitness for a particular purpose or use.

In no event shall Riello (and its subsidiaries) be liable for any indirect, incidental, special or consequential damages including, without limitation, loss of profits, damages for loss of business profits, business interruption, loss of business information, loss of equipment, or other pecuniary loss or compensation for services whether or not it is advised of the possibility of such damages.

With the exception of injuries to persons, Riello's liability is limited to the customer's right to return defective/non-conforming products as provided by the relevant product warranty.

3 Safety and prevention

3.1 Introduction

The burners have been designed and built in compliance with current regulations and directives, applying the known technical rules of safety and envisaging all the potential danger situations.

It is necessary, however, to bear in mind that the imprudent and clumsy use of the equipment may lead to situations of death risk for the user or third parties, as well as the damaging of the burner or other items. Inattention, thoughtlessness and excessive confidence often cause accidents; the same applies to tiredness and sleepiness.

It is a good idea to remember the following:

- The burner must only be used as expressly described. Any other use should be considered improper and therefore dangerous.

In particular:

it can be applied to boilers operating with water, steam, diathermic oil, and to other uses expressly named by the manufacturer;

the type and pressure of the fuel, the voltage and frequency of the electrical power supply, the minimum and maximum deliveries for which the burner has been regulated, the pressurisation of the combustion chamber, the dimensions of the combustion chamber and the room temperature must all be within the values indicated in the instruction manual.

- Modification of the burner to alter its performance and destinations is not allowed.
- The burner must be used in exemplary technical safety conditions. Any disturbances that could compromise safety must be quickly eliminated.
- Opening or tampering with the burner components is not allowed, apart from the parts requiring maintenance.
- Only those parts detailed as available as spare parts by the Manufacturer can be replaced.

3.2 Safety warnings

The dimension of the boiler's combustion chamber must respond to specific values, in order to guarantee a combustion with the lowest polluting emissions rate.

The Technical Service Personnel will be glad to give you all the information for a correct matching of this burner to the boiler.

This burner must only be used for the application it was designed for.

The manufacturer accepts no liability within or without the contract for any damage caused to people, animals and property due to installation, adjustment and maintenance errors or to improper use.

3.3 Basic safety rules

- Children or inexperienced persons must not use the appliance.
- Under no circumstances must the intake grids, dissipation grids and ventilation vents in the installation room be covered up with cloths, paper or any other material.
- Unauthorised persons must not attempt to repair the appliance.
- It is dangerous to pull or twist the electric leads.
- Cleaning operations must not be performed if the appliance is not disconnected from the main power supply.
- Do not clean the burner or its parts with inflammable substances (e.g. petrol, alcohol, etc.). The cover must be cleaned with soapy water.
- Do not place anything on the burner.
- Do not block or reduce the size of the ventilation vents in the installation room.
- Do not leave containers and inflammable products or combustible materials in the installation room.

3.4 Personnel training

The user is the person, body or company that has acquired the machine and intends to use it for the specific purpose. He is responsible for the machine and for the training of the people working around it.

The user:

- undertakes to entrust the machine exclusively to suitably trained and qualified personnel;
- must take all the measures necessary to prevent unauthorised people gaining access to the machine;
- undertakes to inform his personnel in a suitable way about the application and observance of the safety instructions. With that aim, he undertakes to ensure that everyone knows the use and safety instructions for his own duties;
- must inform the manufacturer if faults or malfunctioning of the accident prevention systems are noticed, along with any presumed danger situation.
- Personnel must always use the personal protective equipment envisaged by legislation and follow the indications given in this manual.
- Personnel must observe all the danger and caution indications shown on the machine.
- Personnel must not carry out, on their own initiative, operations or interventions that are not within their province.
- Personnel must inform their superiors of every problem or dangerous situation that may arise.
- The assembly of parts of other makes, or any modifications, can alter the characteristics of the machine and hence compromise operating safety. The manufacturer therefore declines any and every responsibility for any damage that may be caused by the use of non-original parts.

4 Technical description of the burner

4.1 Burner designation

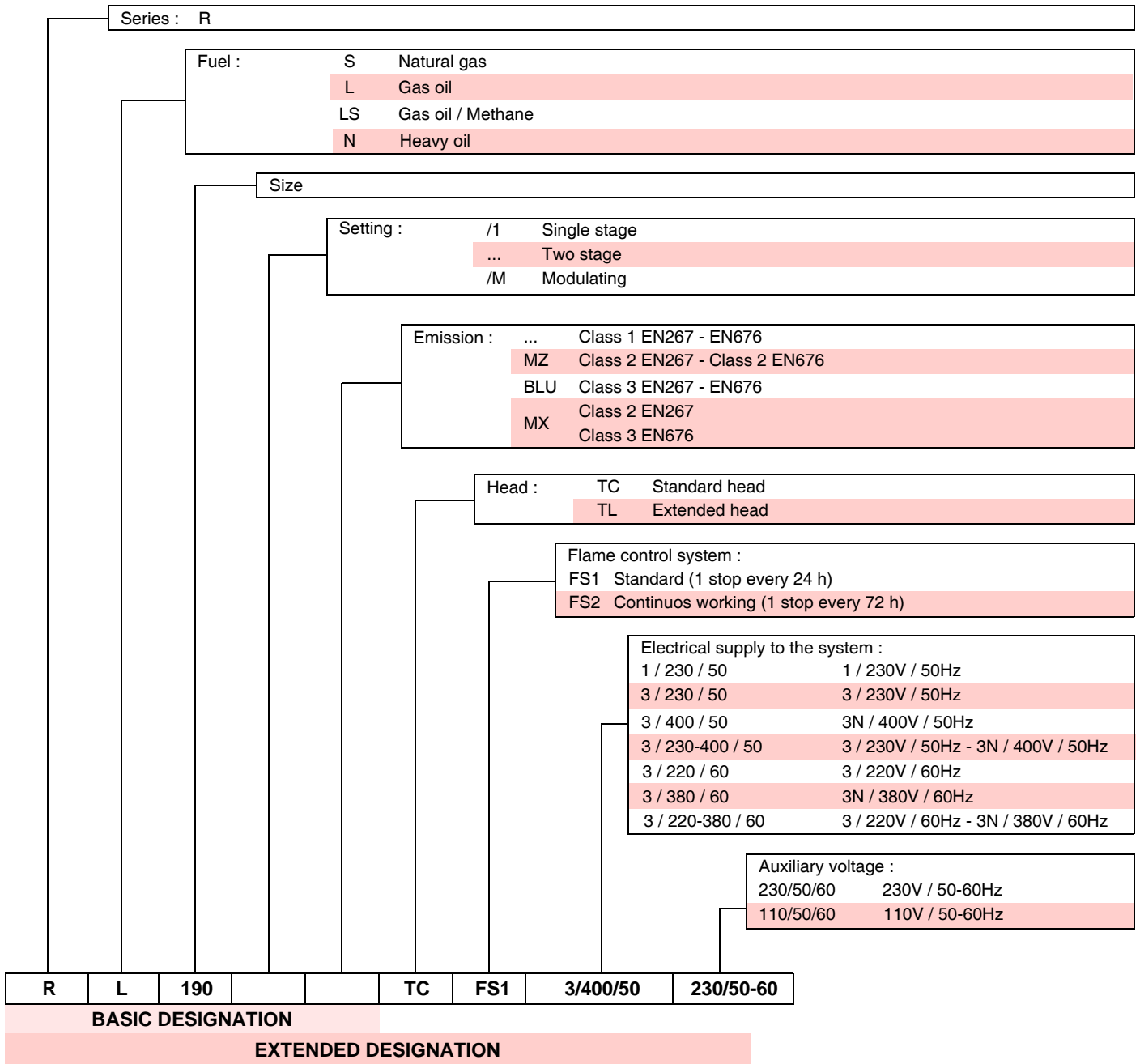

4.2 Models available

Designation	Electrical supply	Code
RL 190 TC	3/400/50	20032719

4.3 Technical data

Model			RL 190
Type			673 T1
Output ⁽¹⁾ Delivery ⁽¹⁾	2 nd stage	kW Mcal/h kg/h	1423 - 2443 1224 - 2100 120 - 206
	1 st stage	kW Mcal/h kg/h	759 - 1423 653 - 1224 64 - 120
Fuel			Gas oil and Blends of gas oil and bio fuel (FAME in accordance with EN 14214) up to 10%
Gas oil	net calorific value	kWh/kg Mcal/kg	11.86 10.2 (10.200 kcal/kg)
	density	kg/dm ³	0.82 - 0.85
	viscosity at 20 °C	mm ² /s max	6 (1.5 °E - 6 cSt)
Operation			<ul style="list-style-type: none"> - Intermittent (min. 1 stop in 24 hours). - Two-stage (high and low flame) and single-stage (all - nothing)
Nozzles		number	2
Standard applications			Boilers: water, steam, diathermic oil
Ambient temperatur		°C	0 - 40
Combustion air temperature		°C max	60
Electrical supply		V/Ph/Hz	400/3/50
Auxiliary power supply		V/Ph/Hz	230/1/50
Electric motor		rpm	2800
		W	4500
		V	400
		A	9.1
Ignition transformer		V1 - V2	230 V - 2 x 5 kV
		I1 - I2	1.9 A - 35 mA
Pump	delivery (at 12 bar)	kg/h	230
	pressure range	bar	10 - 21
	fuel temperatur	°C max	90
Electrical power consumption		W max	5870
Electrical protection			IP 44
Noise levels ⁽³⁾		dB(A)	83.9

Tab. A

(1) Reference conditions: ambient temperature 20°C - Barometric pressure 1013 mbar - Altitude 0 m a.s.l.

(3) Sound pressure measured in manufacturer's combustion laboratory, with burner operating on test boiler and at maximum rated output.

4.4 Packaging - Weight

- The burners stand on a wooden base which can be lifted by fork-lifts. Outer dimensions of packaging are indicated in Tab. B.
- The weight of the burner complete with packaging is indicated in Tab. B.

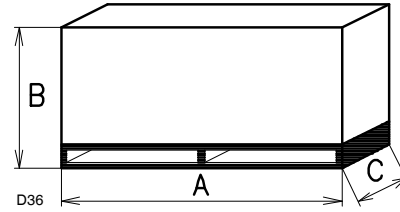

Fig. 1

mm	A	B	C	kg
RL 190	1270	775	890	75

Tab. B

4.5 Overall dimensions

The maximum dimensions of the burner are given in Fig. 2. Bear in mind that inspection of the combustion head requires the burner to be opened and the rear part withdrawn on the slide bars.

The maximum dimension of the burner, without casing, when open is given by measurement I.

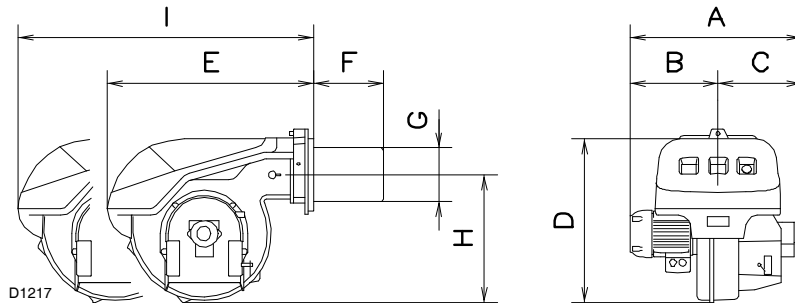

Fig. 2

mm	A	B	C	D	E	F	G	H	I
RL 190	756	366	390	555	712	370	222	430	1166

Tab. C

4.6 Firing rate

The burner can work in two ways: one-stage and two-stage.

1st stage DELIVERY must be selected within area A of the adjacent diagrams.

2nd stage DELIVERY must be selected within area B. This area provides the maximum delivery of the burner in relation to the pressure in the combustion chamber.



The firing rate value (Fig. 3) has been obtained considering an ambient temperature of 20 °C, an atmospheric pressure of 1013 mbar (approx. 0 m above sea level), and with the combustion head adjusted as shown on page 21.

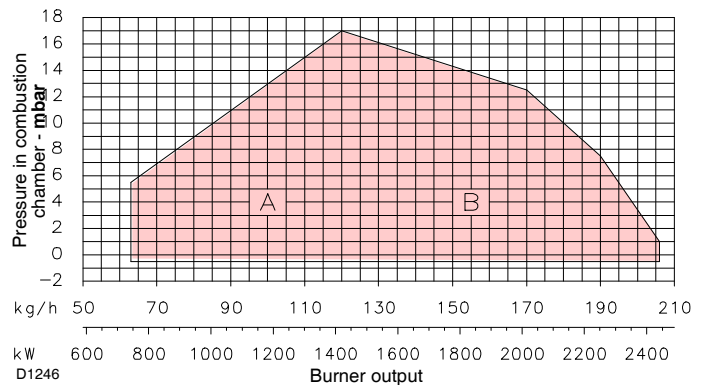

Fig. 3

4.6.1 Test boiler

The firing rate was set in relation to special test boilers in accordance with the methods defined in EN 267 standards. Fig. 4 indicates the diameter and length of the test combustion chamber.

Example: delivery 65 kg/hour: diameter = 60 cm; length = 2 m.

Whenever the burner is operated in a much smaller commercial-available combustion chamber, a preliminary test should be performed.

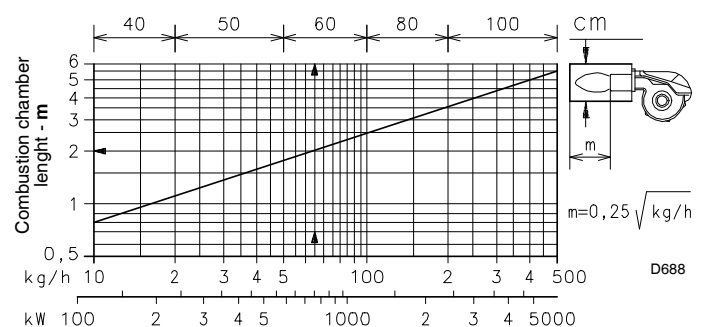

Fig. 4

4.7 Burner description

- 1 Ignition electrodes
- 2 Combustion head
- 3 Screw for combustion head adjustment
- 4 Screw for fixing fan to flange
- 5 Pump
- 6 Hydraulic cylinder for regulation of the air gate valve in 1st and 2nd stage positions. When the burner is not operating the air gate valve is fully closed in order to reduce heat dispersion from the boiler due to the flue draught which draws air from the fan suction inlet.
- 7 Air inlet to fan
- 8 Air gate valves
- 9 Fan pressure test point
- 10 Boiler mounting flange
- 11 Flame stability disk
- 12 Slide bars for opening the burner and inspecting the combustion head
- 13 Extensions for slide bars 12)
- 14 Electrical motor
- 15 Ignition transformer
- 16 Motor contactor and thermal relay with reset button
- 17 1st stage valve
- 18 Terminal strip
- 19 Two switches:
- one "burner off - on"
- one for "1st - 2nd stage operation"
- 20 Fairleads for wiring carried out by the installer
- 21 Control box with lock-out pilot light and lock-out reset button
- 22 Flame inspection window
- 23 Photoresistor for flame presence control
- 24 2nd stage valve
- 25 Safety solenoid valve
- 26 Sockets for electrical connections

Two types of burner failure may occur:

Control box lock-out:

if the control box 22)(Fig. 5) pushbutton lights up, it indicates that the burner is in lock-out. To reset, press the pushbutton.

Motor trip:

release by pressing the pushbutton on thermal relay 16)(Fig. 5).

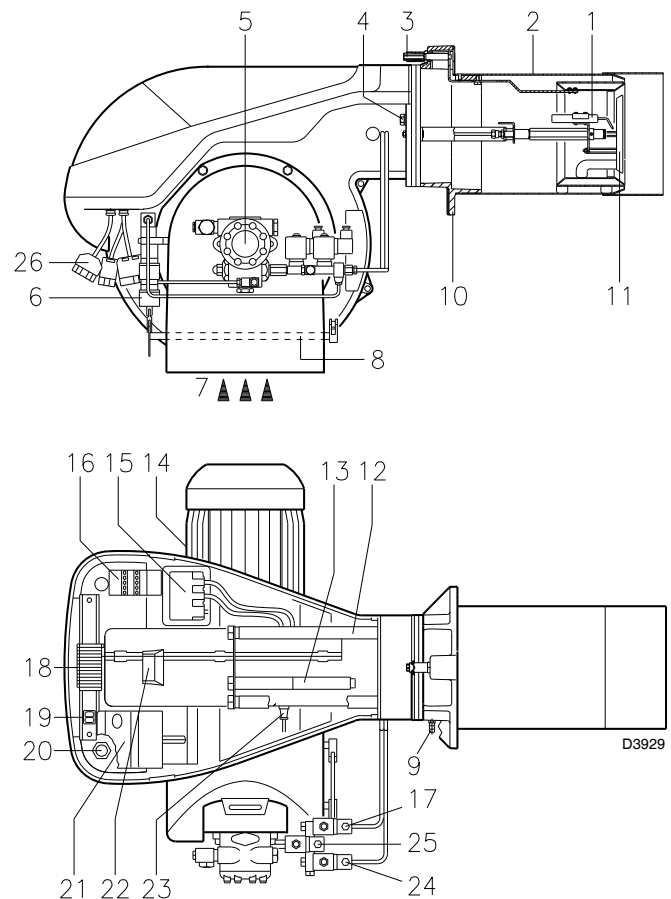

Fig. 5

4.8 Standard equipment

- 2 - Hoses (L = 1350 mm)
- 2 - Gaskets for flexible hoses
- 2 - Nipples for flexible hoses
- 1 - Thermal insulation screen
- 4 - Extensions 13) for slide bars 12)(Fig. 5)
- 4 - Screws to secure the burner flange to the boiler: M 16 x 40
- 2 - Plugs for electrical connections
- 1 - Instruction booklet
- 1 - Spare parts list



In case of use with gas oil containing up to 10% Bio blend, it will be essential to use flexible oil lines suitable for bio fuel use. Please contact Riello for further information.

5 Installation

5.1 Notes on safety for the installation

After carefully cleaning all around the area where the burner will be installed, and arranging the correct lighting of the environment, proceed with the installation operations.



All the installation, maintenance and disassembly operations must be carried out with the electricity supply disconnected.



The installation of the burner must be carried out by qualified personnel, as indicated in this manual and in compliance with the standards and regulations of the laws in force.

5.2 Handling

The packaging of the burner includes a wooden platform, so it is possible to move the burner (still packaged) with a transpallet truck or fork lift truck.



The handling operations for the burner can be highly dangerous if not carried out with the greatest attention: keep any unauthorised people at a distance; check the integrity and suitability of the available means of handling. Check also that the area in which you are working is empty and that there is an adequate escape area (i.e. a free, safe area to which you can quickly move if the burner should fall). When handling, keep the load at not more than 20-25 cm from the ground.



After positioning the burner near the installation point, correctly dispose of all residual packaging, separating the various types of material. Before proceeding with the installation operations, carefully clean all around the area where the burner will be installed.

5.3 Preliminary checks

Checking the consignment



After removing all the packaging, check the integrity of the contents. In the event of doubt, do not use the burner; contact the supplier.





The packaging elements (wooden cage or cardboard box, nails, clips, plastic bags, etc.) must not be abandoned as they are potential sources of danger and pollution; they should be collected and disposed of in the appropriate places.

Checking the characteristics of the burner

Check the identification label of the burner, showing:

- the model (A) (Fig. 6) and type of burner (B);
- the year of manufacture, in cryptographic form (C);
- the serial number (D);
- the electrical input power (E);
- the types of fuel used and the relative supply pressures (F);
- the data of the burner's minimum and maximum output possibilities (G) (see Firing rate).

R.B.L.	A		G	
	B	C		
	D	E		
F				
<small>RIELLO Sp.A I-37045 Legnago (VR)</small>   0036				

D8965

Fig. 6



The output of the burner must be within the boiler's firing rate;



A burner label, or any other component, that has been tampered with, removed or is missing, prevents the definite identification of the burner and makes any installation or maintenance work difficult.

5.4 Installer/Service notes for the use of Gas oil with Bio blends up to 10%

- During the burner installation, check that the gasoil and bio fuel blends are in accordance with Riello specifications (please refer to the chapters "Technical Data" and "Guidance for the use of bio fuel blends up to 10%" within the burner technical manual).
- If a Bio blend is in use the installer must seek information from the end user that their fuel supplier can evidence that the blends of fuel conform to the relevant standards.
- Check that the materials used in the construction of the oil tank and ancillary equipment are suitable for bio fuels, If not these must be upgraded or replaced with Bio compatible parts.
- Particular attention should be given to the oil storage tank and supply to the burner. Riello recommends that existing oil storage tanks are cleaned, inspected and any traces of water are removed BEFORE bio fuel is introduced (Contact the tank manufacturer or oil supplier for further advice). If these recommendations are not respected this will increase the risk of contamination and possible equipment failure.
- In line oil filters should be replaced making sure that they are Bio compatible. Riello recommends a good quality bio compatible oil filter at the tank and a secondary 100 micron filter are used to protect the burner pump and nozzle from contamination.
- The burner hydraulic components and flexible oil lines must be suitable for bio fuel use (check with Riello if in doubt). Riello have carefully chosen the specification of the bio compatible components including the flexible oil lines to protect the pump, safety valve and nozzle. The Riello warranty is dependent upon the use of Riello genuine components including the oil lines, being used. The burner must be commissioned and combustion parameters set to appliance manufacturer's recommendations.
- Regularly check visually for any signs of oil leakage from seals, gaskets and hoses.
- It is strongly recommended that with Bio fuel use, oil filters are inspected and replaced every 4 months. More regularly where contamination is experienced.
- During extended periods of non operation and/or where burners are using oil as a standby fuel, it is strongly recommended that the burner is put into operation for short periods at least every three months.

5.5 Operating position

The burner is designed to work only in the positions 1, 2, 3 and 4. Installation 1 is preferable, as it is the only one that allows performing maintenance operations as described in this manual. Installations 2, 3 and 4 permit operation but make maintenance and inspection of the combustion head difficult, page 25.



Any other position could compromise the correct working of the appliance. Installation 5 is prohibited for safety reasons.

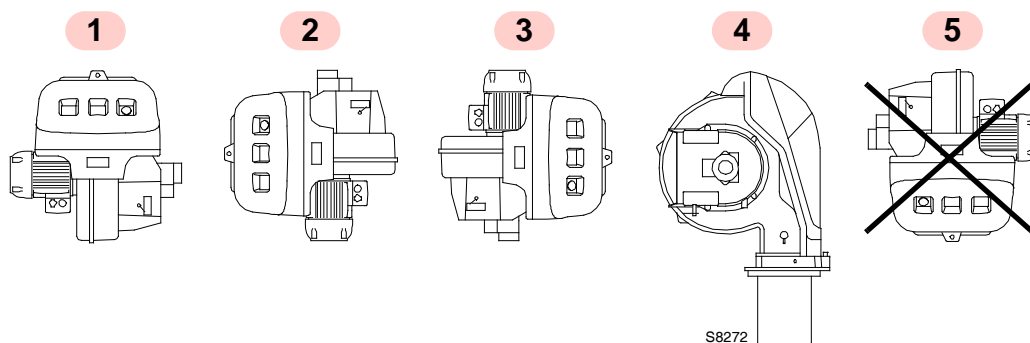

Fig. 7

5.6 Boiler plate

Drill the combustion chamber locking plate as shown in Fig. 8. The position of the threaded holes can be marked using the thermal screen supplied with the burner.

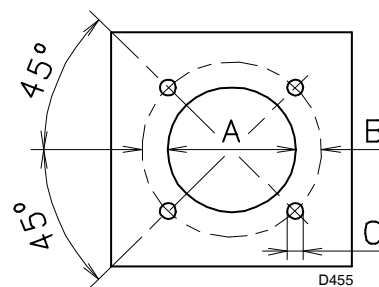

Fig. 8

mm	A	B	C
RL 190	230	325 - 368	M 16

Tab. D

5.7 Blast tube length

The length of the blast tube 9)(Fig. 9) must be selected according to the indications provided by the manufacturer of the boiler, and in any case it must be greater than the thickness of the boiler door complete with its fettling.

For boilers with front flue passes 12)(Fig. 9) or flame inversion chambers, protective fettling in refractory material 10) must be inserted between the boiler fettling 11) and the blast tube 9).

This protective fettling must not compromise the extraction of the blast tube.

For boilers having a water-cooled front the refractory fettling 10)-11) is not required unless it is expressly requested by the boiler manufacturer.

5.8 Securing the burner to the boiler

Disassemble the blast tube 9)(Fig. 9) from the burner 6) by proceeding as follows:

- loosen the four screws 3) and remove the cover 1);
- remove the screws 2) from the two slide bars 5);
- remove the two screws 4) fixing the burner 6) to the flange 7);
- withdraw the blast tube 9) complete with flange 7) and slide bars 5).
- Secure flange 7) to the boiler plate interposing the supplied gasket 8).
- Use the 4 screws provided after having protected the thread with anticruffing products.



The burner-boiler seal must be airtight.

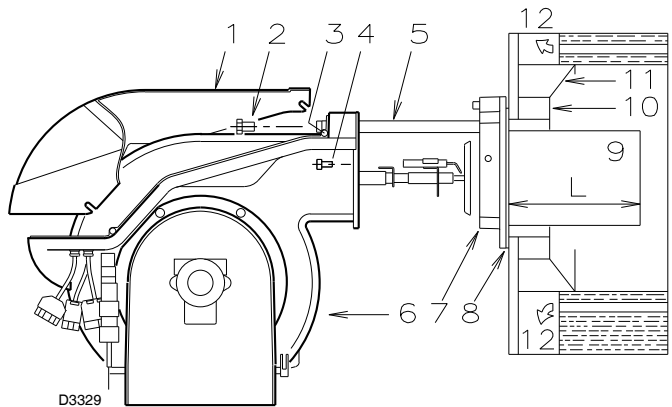

Fig. 9

5.9 Nozzle installation

The burner complies with the emission requirements of the EN 267 standard.

In order to guarantee that emissions do not vary, recommended and/or alternative nozzles specified by Riello in the Instruction and warning booklet should be used.



It is advisable to replace nozzles every year during regular maintenance operations.



The use of nozzles other than those specified by Riello S.p.A. and inadequate regular maintenance may result into emission limits non-conforming to the values set forth by the regulations in force, and in extremely serious cases, into potential hazards to people and objects.

The manufacturing company shall not be liable for any such damage arising from nonobservance of the requirements contained in this manual.

5.9.1 Choice of nozzles for 1st and 2nd stage

Both nozzles must be chosen from among those listed in table ().

- The first nozzle determines the delivery of the burner in the 1st stage.
- The second nozzle works together with the 1st nozzle to determine the delivery of the burner in the 2nd stage.

The deliveries of the 1st and 2nd stages must be contained within the value range indicated on page 9.

GPH	kg/h			kW 12 bar
	10 bar	12 bar	14 bar	
5.00	19.2	21.2	23.1	251.4
5.50	21.1	23.3	25.4	276.3
6.00	23.1	25.5	27.7	302.4
6.50	25.0	27.6	30.0	327.3
7.00	26.9	29.7	32.3	352.3
7.50	28.8	31.8	34.6	377.2
8.00	30.8	33.9	36.9	402.1
8.30	31.9	35.2	38.3	417.5
8.50	32.7	36.1	39.2	428.2
9.00	34.6	38.2	41.5	453.1
9.50	36.5	40.3	43.8	478.0
10.0	38.4	42.4	46.1	502.9
10.5	40.4	44.6	48.4	529.0
11.0	42.3	46.7	50.7	553.9
12.0	46.1	50.9	55.3	603.7
12.3	47.3	52.2	56.7	619.1
13.0	50.0	55.1	59.9	653.5
13.8	53.1	58.5	63.3	693.8
14.0	53.8	59.4	64.5	704.5
15.0	57.7	63.6	69.2	754.3
15.3	58.8	64.9	70.5	769.7
16.0	61.5	67.9	73.8	805.3
17.0	65.4	72.1	78.4	855.1
17.5	67.3	74.2	80.7	880.0
18.0	69.2	76.4	83.0	906.1
19.0	73.0	80.6	87.6	956.0
19.5	75	82.7	89.9	980.9
20.0	76.9	84.8	92.2	1005.8
21.5	82.7	91.2	99.1	1081.7
22.0	84.6	93.3	101.4	1106.6

Tab. E



Use nozzles with a 60° spray angle at the recommended pressure of 12 bar.

As a rule the two nozzles have equal deliveries but the 1st stage nozzle may have a delivery less than 50% of the total delivery when a reduction of the counter-pressure peak is desired at the moment of starting (the burner allows good combustion rates also with a 40 - 100 % ratio between the 1st and 2nd stage).

Example:

boiler output = 1630 kW - efficiency 90 %
 Output required by the burner = 1630 : 0.9 = 1812 kW;
 1812 : 2 = 906 kW per nozzle;
 therefore, two equal, 60°, 12 bar nozzles are required:
 1° = 18 GPH - 2° = 18 GPH,
 or the following two different nozzles:
 1° = 16 GPH - 2° = 20 GPH



The value of has been obtained considering: gas oil density 0.84 kg/dm³ - viscosity 4.2 cSt/20 °C - temperature 10 °C

5.9.2 Nozzle assembly

At this stage of installation the burner is still disassembled from the blast tube; it is therefore possible to fit the nozzle with the box spanner 1)(Fig. 10) (16 mm), after having removed the plastic plugs 2), fitting the spanner through the central hole in the flame stability disk.



Do not use any sealing products such as gaskets, sealing compound, or tape.

Be careful to avoid damaging the nozzle sealing seat.

The nozzles must be screwed into place tightly but not to the maximum torque value provided by the wrench.

The nozzle for the 1st stage of operation is the one lying beneath the firing electrodes (Fig. 11)

Make sure that the electrodes are positioned as shown in (Fig. 11)

Finally refit the burner 3)(Fig. 12) to the slide bars 2) and slide it up to the flange 5), keeping it slightly raised to prevent the flame stability disk from pressing against the blast tube.

Tighten the screws 1) on the slide bars 2) and screws 4) fixing the burner to the flange.

If it proves necessary to change a nozzle with the burner already fitted to the boiler, proceed as outlined below:

- retract the burner on its slide bars as shown in (Fig. 9 at page 14);
- remove the nuts 1)(Fig. 13) and the disk 2);
- use spanner 3) to change the nozzles.

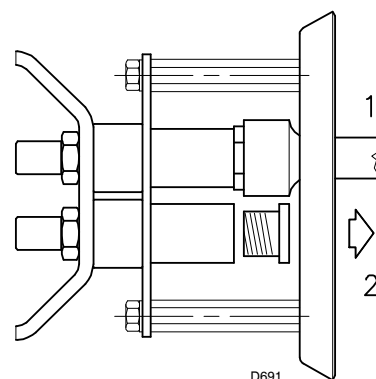

Fig. 10

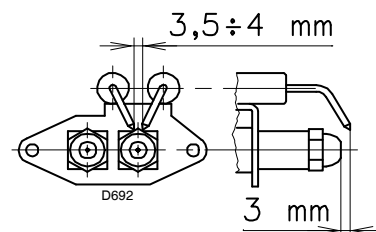

Fig. 11

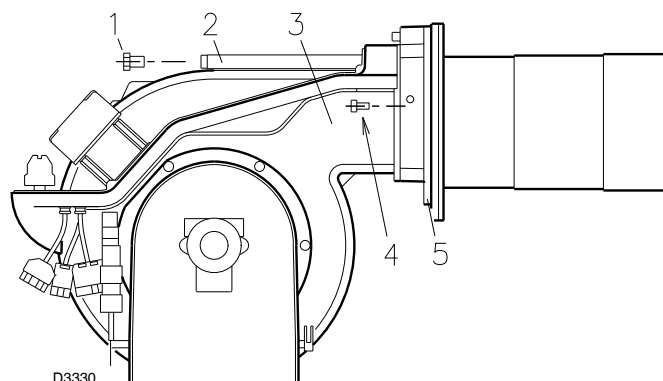

Fig. 12

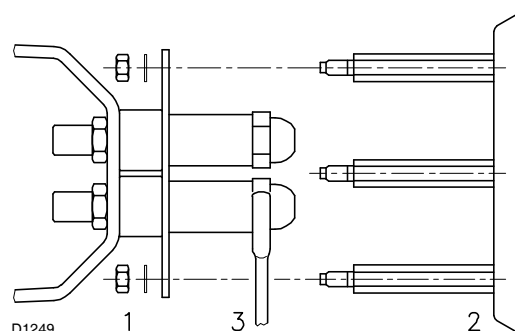

Fig. 13

5.10 Gas oil supply



Where gas oil containing bio diesel is in use, it is recommended to avoid over oxygenation of the blended fuels.

Where at all possible avoid the use of two pipe systems where the circulated fuel is returned to the tank.

If this cannot be avoided make sure that the return pipe is normally below the surface of the fuel level within the storage tank.



In case of use with gas oil containing up to 10% Bio blend, it will be essential to use flexible oil lines suitable for bio fuel use.

Please contact Riello for further information.



It is strongly recommended a periodic check of the pump pressure operation (annually or better every six months, if the burner operation is continuous).



You are advised to use additional filters on the fuel supply line.

Riello recommends a good quality fuel filter at the tank (Fig. 14 - Fig. 15) and a secondary filter (100 µ for gas oil and 15 µ for kerosene) are used to protect the burner pump and nozzle from contamination.

In case of Biodiesel use, pay attention to install Biocompatible filters.

5.10.1 Double-pipe circuit

The burner is equipped with a self-priming pump which is capable of feeding itself within the limits listed in the Tab. F.

The tank higher than the burner A (Fig. 14)

The distance "P" must not exceed 10 meters in order to avoid subjecting the pump's seal to excessive strain; the distance "V" must not exceed 4 meters in order to permit pump self-priming even when the tank is almost completely empty.

The tank lower than the burner B (Fig. 14)

Pump depression values higher than 0.45 bar (35 cm Hg) must not be exceeded because at higher levels gas is released from the fuel, the pump starts making noise and its working life-span decreases.

It is good practice to ensure that the return and suction lines enter the burner from the same height; in this way it will be more improbable that the suction line fails to prime or stops priming.

5.10.2 The loop circuit

A loop circuit consists of a loop of piping departing from and returning to the tank with an auxiliary pump that circulates the fuel under pressure.

A branch connection from the loop goes to feed the burner.

This circuit is extremely useful whenever the burner pump does not succeed in self-priming because the tank distance and/or height difference are higher than the values listed in the Tab. F.

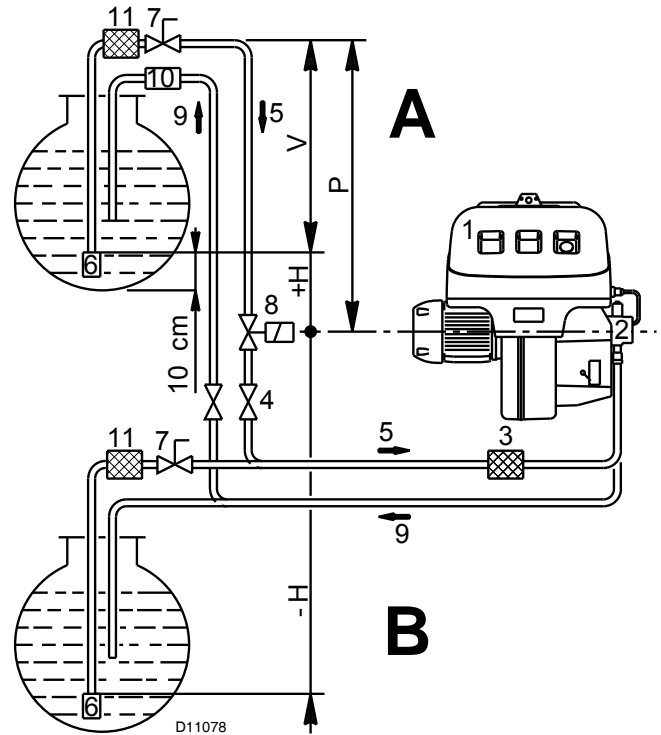

Fig. 14

Key (Fig. 14)

- H Pump/Foot valve height difference
- L Piping length
- ∅ Inside pipe diameter
- 1 Burner
- 2 Pump
- 3 Filter
- 4 Manual on/off valve
- 5 Suction line
- 6 Foot valve
- 7 Rapid closing manual valve remote controlled (only Italy)
- 8 On/off solenoid valve (only Italy)
- 9 Return line
- 10 Check valve (only Italy)
- 11 Tank filter

+/- H (meters)	L (meters)		
	∅ 12 (mm)	∅ 14 (mm)	∅ 16 (mm)
+ 4.0	71	138	150
+ 3.0	62	122	150
+ 2.0	53	106	150
+ 1.0	44	90	150
+ 0.5	40	82	150
0	36	74	137
- 0.5	32	66	123
- 1.0	28	58	109
- 2.0	19	42	81
- 3.0	10	26	53
- 4.0	-	10	25

Tab. F

5.10.3 Single-pipe circuit

In order to obtain single-pipe working it is necessary to unscrew the return hose, remove the by-pass screw 6)(Fig. 25) and then screw the plug 7)(Fig. 25).

The distance "P" must not exceed 10 meters in order to avoid subjecting the pump's seal to excessive strain; the distance "V" must not exceed 4 meters.

For the priming pump loosen the screw 3)(Fig. 17) in order to bleed off the air contained in the suction line and wait until the fuel flows out.

Key (Fig. 15)

- H Pump/Foot valve height difference
- L Piping length
- ∅ Inside pipe diameter
- 1 Burner
- 2 Pump
- 3 Filter
- 4 Manual on/off valve
- 5 Suction line
- 6 Foot valve
- 7 Rapid closing manual valve remote controlled (only Italy)
- 8 On/off solenoid valve (only Italy)
- 11 Tank filter

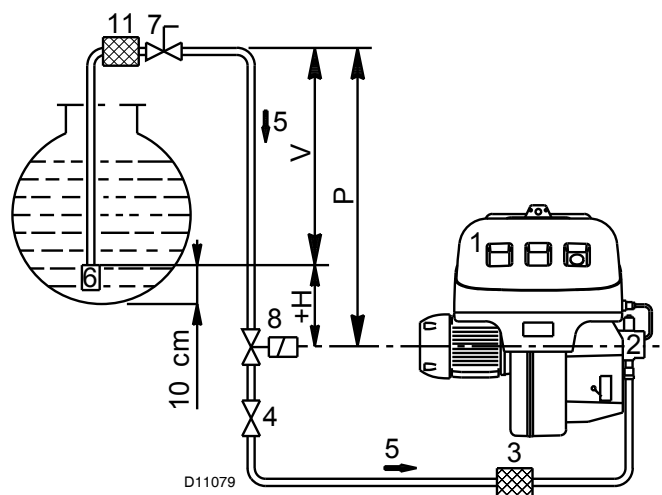

Fig. 15

+/- H (meters)	L (meters)		
	∅ 12 (mm)	∅ 14 (mm)	∅ 16 (mm)
+ 4.0	71	138	150
+ 3.0	62	122	150
+ 2.0	53	106	150
+ 1.0	44	90	150
+ 0.5	40	82	150

Tab. G

5.11 Hydraulic connections

The pumps are equipped with a by-pass that connects return line with suction line. The pumps are installed on the burner with the by-pass closed by screw 6)(Fig. 17).

It is therefore necessary to connect both hoses to the pump.

The pump will break down immediately if it is run with the return line closed and the by-pass screw inserted.

Remove the plugs from the suction and return connections of the pump.

Insert the hose connections with the supplied seals into the connections and screw them down.

Take care that the hoses are not stretched or twisted during installation.

Install the hoses where they cannot be stepped on or come into contact with hot surfaces of the boiler.

Now connect the other end of the hoses to the suction and return lines by using the supplied nipples.

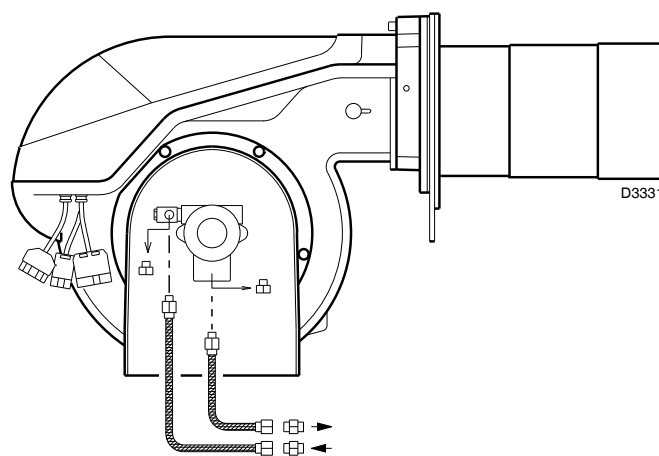

Fig. 16

5.12 Pump



In case of use with gas oil containing up to 10% Bio blend, it will be essential to use flexible oil lines suitable for bio fuel use. Please contact Riello for further information.

5.12.2 Pump priming



Before starting the burner, make sure that the tank return line is not clogged.

Obstructions in the line could cause the sealing organ located on the pump shaft to break. (The pump leaves the factory with the by-pass closed).

- Also check to make sure that the valves located on the suction line are open and that there is sufficient fuel in the tank.
- For self-priming to take place, one of the screws 3)(Fig. 17) of the pump, must be loosened in order to bleed off the air contained in the suction line.
- Start the burner by closing the control devices, with switch 1)(Fig. 18) in the "ON" position. The pump must rotate in the direction of the arrow marked on the cover.
- The pump can be considered to be primed when the gas oil starts coming out of the screw 3)(Fig. 17). Stop the burner: switch 1)(Fig. 18) set to "OFF" and tighten the screw 3).

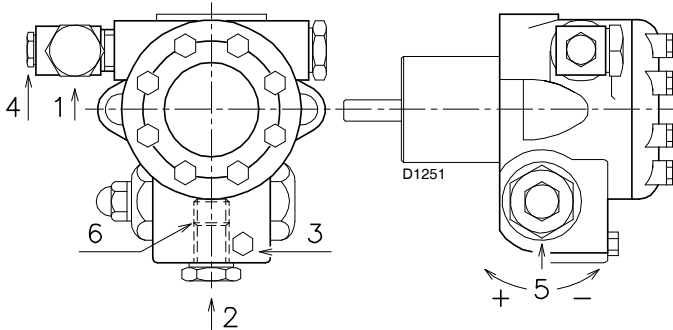

Fig. 17

- | | | |
|---|---------------------------|--------|
| 1 | Suction | G 1/2" |
| 2 | Return | G 1/2" |
| 3 | Pressure gauge connection | G 1/8" |
| 4 | Vacuum meter connection | G 1/8" |
| 5 | Pressure adjustment screw | |
| 6 | Screw for by-pass | |

5.12.1 Technical data

Suntec E7

Min. delivery rate at 12 bar pressure	kg/h	230
Delivery pressure range	bar	10 - 21
Max. suction depression	bar	0.45
Viscosity range	mm ² /s (cSt)	2.8 - 200
Max. gas oil temperature	°C	90
Max. suction and return pressure	bar	1.5
Pressure calibration in the factory	bar	12
Filter mesh width	mm	0.17

Tab. H

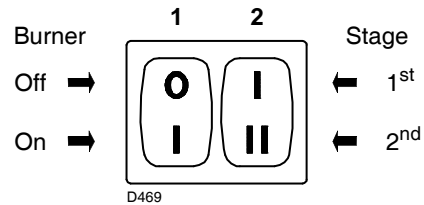

Fig. 18

The time required for this operation depends upon the diameter and length of the suction tubing. If the pump fails to prime at the first starting of the burner and the burner locks out, wait approx. 15 seconds, reset the burner, and then repeat the starting operation as often as required. After 5 or 6 starting operations allow 2 or 3 minutes for the transformer to cool.

Do not illuminate the photocell or the burner will lock out; the burner should lock out anyway about 10 seconds after it starts.



The a.m. operation is possible because the pump is already full of fuel when it leaves the factory.

If the pump has been drained, fill it with fuel through the opening on the vacuum meter prior to starting; otherwise, the pump will seize.

Whenever the length of the suction piping exceeds 20-30 meters, the supply line must be filled using a separate pump.

6 Electrical system

6.1 Notes on safety for the electrical wiring



DANGER

- The electrical wiring must be carried out with the electrical supply disconnected.
- Electrical wiring must be carried out by qualified personnel and in compliance with the regulations currently in force in the country of destination. Refer to the wiring diagrams.
- The manufacturer declines all responsibility for modifications or connections different from those shown in the wiring diagrams.
- Do not invert the neutral with the phase in the electrical supply line. Any inversion would cause a lockout due to firing failure.
- Check that the electrical supply of the burner corresponds to that shown on the identification label and in this manual.
- The burners have been set for intermittent operation. This means they should compulsorily be stopped at least once every 24 hours to enable the control box to perform checks of its own start-up efficiency. Normally the boiler's thermostat/pressure switch ensures the stopping of the burner.
If this is not the case, it is necessary to apply in series with IN a timer switch that turns off the burner at least once every twenty-four hours. Refer to the wiring diagrams.
- The electrical safety of the device is obtained only when it is correctly connected to an efficient earthing system, made according to current standards. It is necessary to check this fundamental safety requirement. In the event of doubt, have the electrical system checked by qualified personnel.
- The electrical system must be suitable for the maximum input power of the device, as indicated on the label and in the manual, checking in particular that the section of the cables is suitable for the input power of the device.
- For the main power supply of the device from the electricity mains:
 - do not use adapters, multiple sockets or extensions;
 - use an omnipolar switch, as indicated by the current safety standards.
- Do not touch the device with wet or damp body parts and/or in bare feet.
- Do not pull the electric cables.

Before carrying out any maintenance, cleaning or checking operations:



DANGER

disconnect the electrical supply from the burner by means of the main system switch;



DANGER

isolate the fuel supply.

If the cover is still present, remove it and proceed with the electrical wiring according to the wiring diagrams.

6.2 Electrical connections



WARNING

Electrical wiring must be made in accordance with the regulations currently in force in the country of destination and by qualified personnel.
 Riello S.p.A. declines all liability for modifications or connections other than those shown on these diagrams.

Use flexible cables according to regulations EN 60 335-1:

- if in PVC boot, use at least H05 VV-F
- if in rubber boot, use at least H05 RR-F

All the cables to be connected to the burner terminal strip 8)(Fig. 19) must be routed through the fairleads.

The fairleads can be used in various ways. One example is given below:

- | | | |
|---|---------|--------------------------|
| 1 | Pg 13.5 | Three-phase power supply |
| 2 | Pg 9 | Set up for fair lead |
| 3 | Pg 11 | Set up for fair lead |
| 4 | Pg 13,5 | Set up for fair lead |

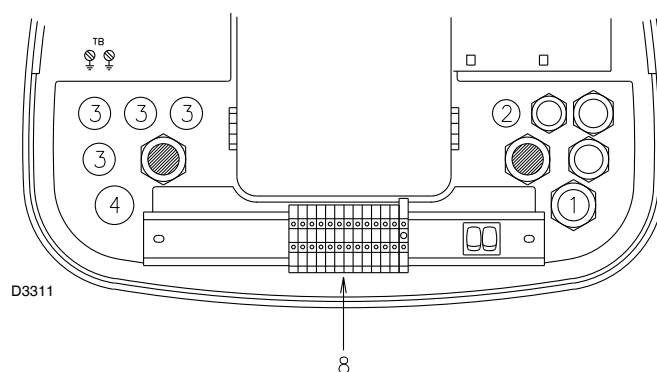

Fig. 19

6.3 Calibration of thermal relay

This is required to avoid motor burn-out in the event of a significant increase in power absorption caused by a missing phase.

- If the motor is star-powered, **400V**, the cursor should be positioned on "MIN".
- If the motor is delta-powered, **230V**, the cursor should be positioned on "MAX".

Even if the scale of the thermal cut-out does not include rated motor absorption at **400V**, protection is still ensured in any case.

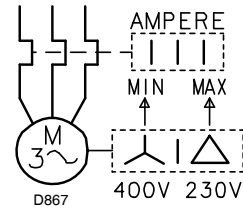

Fig. 20



- Do not invert the neutral with the phase wire in the electricity supply line. Any inversion would cause a lockout due to firing failure.
- Only use original spare parts to replace the components.

7 Start-up, calibration and operation of the burner

7.1 Notes on safety for the first start-up



The first start-up of the burner must be carried out by qualified personnel, as indicated in this manual and in compliance with the standards and regulations of the laws in force.



Check the correct working of the adjustment, command and safety devices.

7.2 Burner firing

Set switch 1)(Fig. 21) to "ON".

During the first firing, during the passage from the 1st to the 2nd stage, there is a momentary lowering of the fuel pressure caused by the filling of the 2nd stage nozzle tubing.

This lowering of the fuel pressure can cause the burner to lock-out and can sometimes give rise to pulsations.

Once the following adjustments have been made, the firing of the burner must generate a noise similar to the noise generated during operation.

If one or more pulsations or a delay in firing in respect to the opening of the light oil solenoid valve occur, see the suggestions provided on page 28.

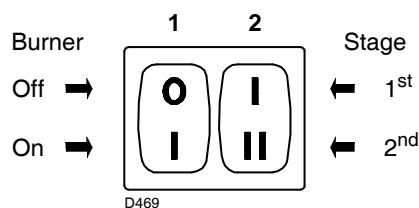

Fig. 21

7.3 Burner calibration

The optimum calibration of the burner requires an analysis of the flue gases at the boiler outlet.

Adjust successively:

- Combustion head
- 1st and 2nd stage nozzles
- Pump pressure
- 1st stage fan air gate valve
- 2nd stage fan air gate valve

7.3.1 Combustion head setting

The setting of the combustion head depends exclusively on the burner delivery in the 2nd stage - in other words, the combined delivery of the two nozzles selected in Tab. E at page 14.

Turn screw 4)(Fig. 22) until the notch shown in diagram (Fig. 23) is level with the front surface of flange 5)(Fig. 22).

Example:

The burner with two 18 GPH nozzles and 12 bar pump pressure. Find the delivery of the two 18 GPH nozzles in (Tab. E at page 14): $76.4 + 76.4 = 152.8$ kg/h.

Diagram (Fig. 23) indicates that for a delivery of 152.8 kg/h the burner requires the combustion head to be set to approx. three notches, as shown in Fig. 22.

7.3.2 1st and 2nd stage nozzles

See the information listed at page 14.

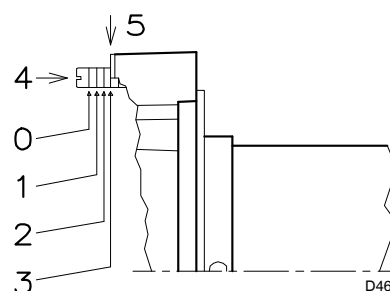

Fig. 22



Fig. 23

7.3.3 Pump pressure

12 bar: this is the pressure calibrated in the factory which is usually sufficient for most purposes. Sometimes, this pressure must be adjusted to:

10 bar: in order to reduce fuel delivery. This adjustment is possible only if the surrounding temperature remains above 0°C. Never calibrate to pressures below 10 bar, at which pressures the cylinders may have difficulty in opening;

14 bar: order to increase fuel delivery or to ensure firings even at temperatures of less than 0°C. In order to adjust pump pressure, use the relevant screw 5)(Fig. 17 at page 18).

7.3.4 1st stage fan air gate valve

Keep the burner operating at 1st stage by setting the switch 2) (Fig. 21) to the 1st stage position.

Opening of the air gate valves 6)(Fig. 24) must be adjusted in proportion to the selected nozzle: the index 8) must be aligned with the notch indicated on the graduated sector 7).

This adjustment is achieved by turning the hex element 2):

- towards the right direction (- sign) the opening is reduced;
- towards the left direction (+ sign) the opening increases.

7.3.5 2st stage fan air gate valve

Set switch 2)(Fig. 21) to the 2nd stage position and adjust the air gate valve 6)(Fig. 24) by turning the hex element 4), after having loosened the ring nut 3).



In order to facilitate adjustment of hex elements 2) and 4)(Fig. 24), use a 3 mm Allen key 5).

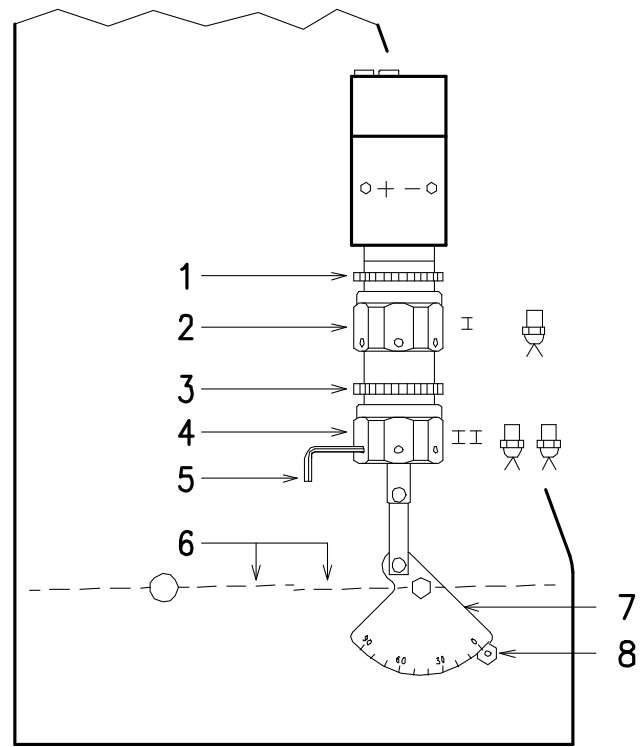

D1252

Fig. 24

7.4 Burner operation

7.4.1 Burner starting

Starting phases with progressive time intervals shown in seconds:

control device TL closes.

After about 3s:

- 0 s:** The control box starting cycle begins.
- 2 s:** The fan motor starts.
- 3 s:** The ignition transformer is connected.
The pump 3)(Fig. 25) sucks the fuel from the tank through the piping 1) and the filter 2) and pumps it under pressure to delivery.
The piston 4) rises and the fuel returns to the tank through the piping 5) - 7).
- 22 s:** Solenoid valves 8) and 16) open and the fuel passes through the piping 9) and filter 10) and is then sprayed out through the nozzle, igniting when it comes into contact with the spark. This is the 1st stage flame.
- 29 s:** The ignition transformer switches off.
- 36 s:** If the control device TR is closed or has been replaced by a jumper wire, the 2nd stage solenoid valve 11), energized, opens two passages: one to piping 12), filter 13), and the 2nd stage nozzle, and the other to the cylinder 15), piston B, that opens the fan air gate valve in the 2nd stage. The starting cycle comes to an end.

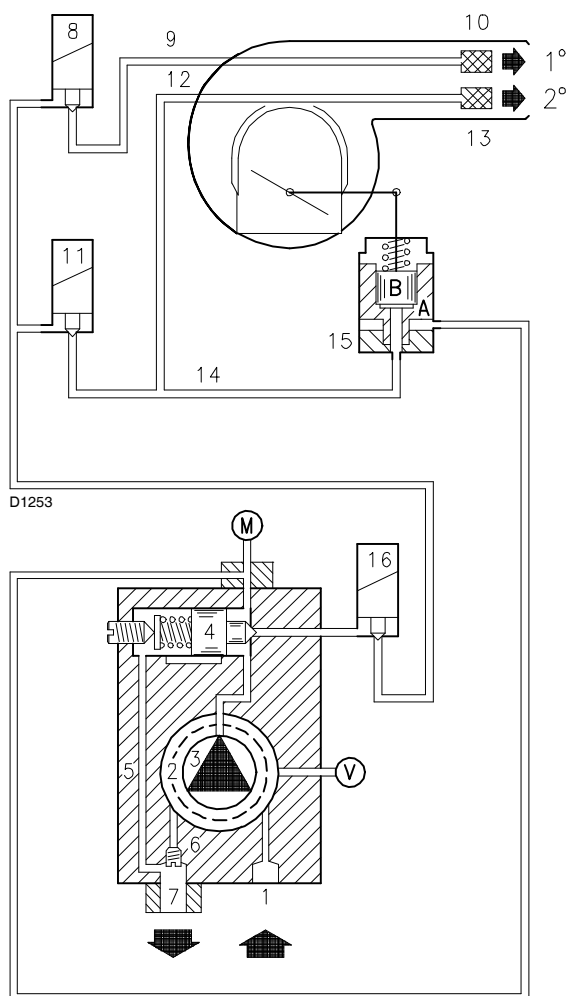

Fig. 25

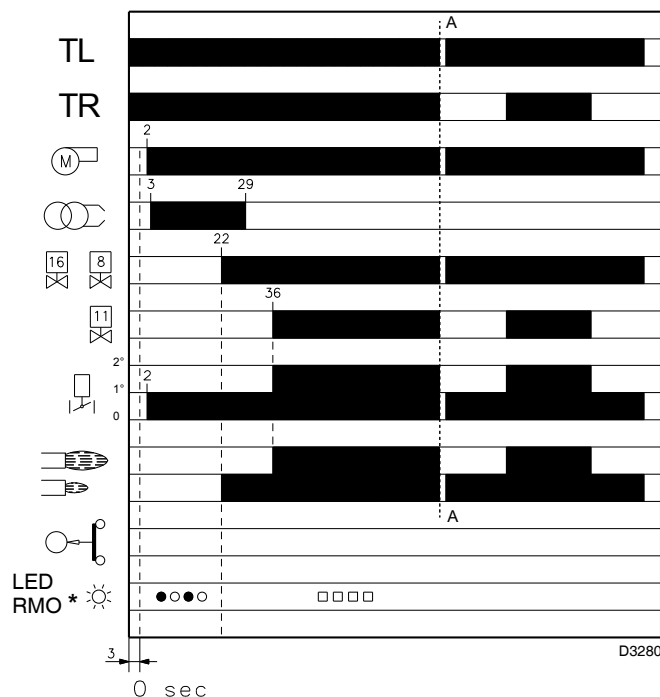

Fig. 26

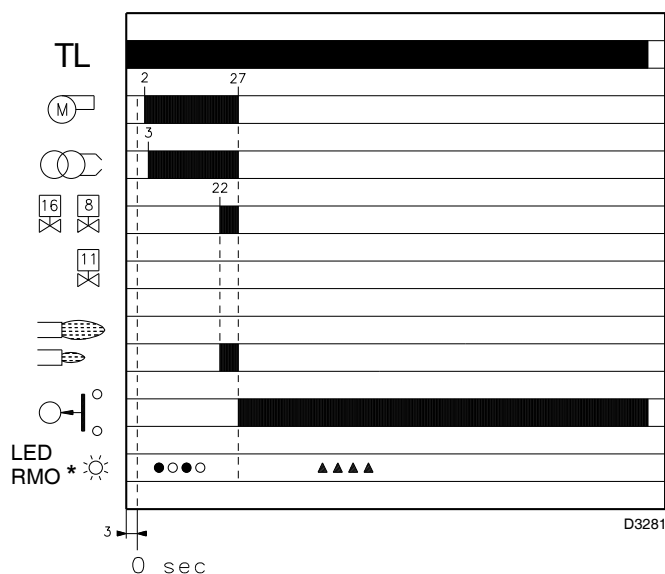

Fig. 27

* ○ Off ● Yellow □ Green ▲ Red
For further details see page 27.

7.4.2 Steady state operation

System equipped with one control device TR

Once the starting cycle has come to an end, the command of the 2nd stage solenoid valve passes on to the control device TR that controls boiler temperature or pressure.

- When the temperature or the pressure increases until the control device TR opens, solenoid valve 11)(Fig. 25) closes, and the burner passes from the 2nd to the 1st stage of operation.
- When the temperature or pressure decreases until the control device TR closes, solenoid valve 11) opens, and the burner passes from the 1st to the 2nd stage of operation. And so on.
- The burner stops when the demand for heat is less than the amount of heat delivered by the burner in the 1st stage. In this case, the control device TL opens, and solenoid valves 8)-16) close, the flame immediately goes out. The fan's air gate valve closes completely.

Systems not equipped with control device TR (jumper wire installed)

The burner is fired as described in the case above. If the temperature or pressure increase until control device TL opens, the burner shuts down (Section A-A in the diagram Fig. 26).

When the solenoid valve 11) de-energizes, the fuel contained in the cylinder 15), piston B, is discharged through the nozzle.

7.4.3 Firing failure

If the burner does not fire, it goes into lock-out within 5 s of the opening of the 1st stage valve and 30 s after the closing of control device TL.

The control box red pilot light will light up.

7.4.4 Undesired shutdown during operation

If the flame goes out during operation, the burner shuts down automatically within 1 second and automatically attempts to start again by repeating the starting cycle.

7.5 Final checks

- Darken the photoresistor and switch on the control devices: the burner should start and then lock-out about 5 s after opening of the 1st stage operation valve.
- Illuminate the photoresistor and switch on the control devices: the burner should start and then go into lock-out after about 10 s.
- Obscure the photocell while the burner is in 2nd stage operation, the following must occur in sequence: flame extinguished within 1 s, pre-purging for about 20-28 s, sparking for about 5 s, burner goes into lock-out.
- Switch off control device TL followed by control device TS while the burner is operating: the burner should stop.

8 Maintenance

8.1 Notes on safety for the maintenance

The periodic maintenance is essential for the good operation, safety, yield and duration of the burner.

It allows you to reduce consumption and polluting emissions and to keep the product in a reliable state over time.



The maintenance interventions and the calibration of the burner must only be carried out by qualified, authorised personnel, in accordance with the contents of this manual and in compliance with the standards and regulations of current laws.

Before carrying out any maintenance, cleaning or checking operations:



Disconnect the electrical supply from the burner by means of the main system switch.



Close the fuel interception tap.

8.2 Maintenance programme

8.2.1 Maintenance frequency

The combustion system should be checked at least once a year by a representative of the manufacturer or another specialised technician.

8.2.2 Checking and cleaning

Combustion

The optimum calibration of the burner requires an analysis of the flue gases.

Significant differences with respect to the previous measurements indicate the points where more care should be exercised during maintenance.

Combustion head

Check to make sure that all the parts of the combustion head are in good condition, positioned correctly, free of all impurities, and that no deformation has been caused by operation at high temperatures.

Fan

Check to make sure that no dust has accumulated inside the fan or on its blades, as this condition will cause a reduction in the air flow rate and provoke polluting combustion.

Boiler

Clean the boiler as indicated in its accompanying instructions in order to maintain all the original combustion characteristics intact, especially the flue gas temperature and combustion chamber pressure.

Burner

Check for excess wear or loose screws. Also make sure that the screws securing the electrical leads in the burner connections are fully tightened.

Clean the outside of the burner.

Photocell

Clean the glass cover from any dust that may have accumulated. Photocell 1)(Fig. 28) can be removed by pulling it outward forcefully.

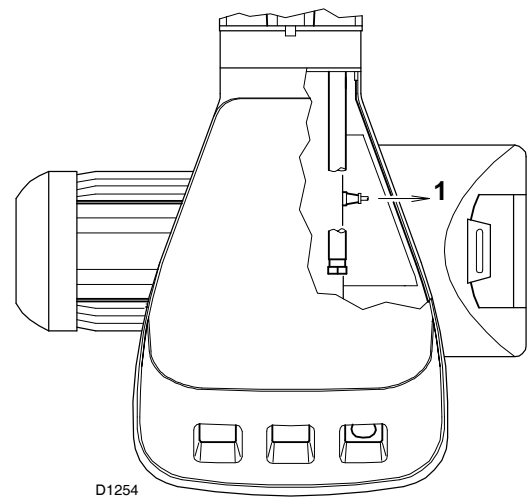

Fig. 28

Flame inspection window

Clean the glass (Fig. 29).

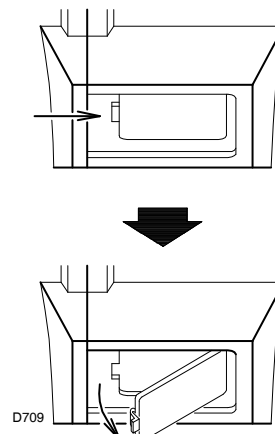

Fig. 29

Filters

Check the filtering baskets on line and at nozzle present in the system. Clean or replace if necessary.

If rust or other impurities are observed inside the pump, use a separate pump to lift any water and other impurities that may have deposited on the bottom of the tank.

Pump

The delivery pressure must be stable. The depression must be less than 0.4 bar. Unusual noise must not be evident during pump operation.

If the pressure is found to be unstable or if the pump runs noisily, the flexible hose must be detached from the line filter and the fuel must be sucked from a tank located near the burner. This measure permits the cause of the anomaly to be traced to either the suction piping or the pump.

If the pump is found to be responsible, check to make sure that the filter is not dirty. The vacuumeter is installed upstream from the filter and consequently will not indicate whether the filter is clogged or not. Contrarily, if the problem lies in the suction line, check to make sure that the filter is clean and that air is not entering the piping.

Please check that the supply line and filters are clear. The use of a pump vacuum gauge will assist in this. This measure permits the cause of the anomaly to be traced to either the suction line or the pump.

If the problem lies in the suction line, check to make sure that the filter is clean and that air is not entering the piping.

Hoses

- Check periodically the flexible pipes conditions. They have to be replaced at least **every 2 years**.
- In case of use of gas oil and bio fuel blends, it is strongly recommended to inspect **even more frequently** the hoses and replace them where contamination has occurred.
- Check to make sure that the hoses are still in good condition.

Nozzles

Do not clean the nozzle openings; do not even open them. The nozzle filters however may be cleaned or replaced as required. It is advisable to replace nozzles every year during regular maintenance operations. Combustion must be checked after the nozzles have been changed.

Fuel tank

If water or contamination is present within the fuel tank, it is essential that this is removed before the equipment is to be used. This is extremely important when gas oil containing Bio diesel is in use. If in doubt about how to achieve this then please contact the fuel or oil tank supplier.

Combustion

In case the combustion values found at the beginning of the intervention do not respect the standards in force or, in any case, do not correspond to a proper combustion, contact the Technical Assistant and have him carry out the necessary adjustments.

EN 267	Excess air		
	Max output $\lambda \leq 1.2$		Min output $\lambda \leq 1.3$
Theoretical max. CO ₂ 0 % O ₂	Calibration CO ₂ %		CO mg/kWh
	$\lambda = 1,2$	$\lambda = 1,3$	
15.2	12.6	11.5	≤ 100

8.3 Opening the burner



Disconnect the electrical supply from the burner.

- Loosen screws 1)(Fig. 30) and withdraw the cover 2).
- Unscrew screws 3).
- Fit the two extensions 4) supplied with the burner onto the slide bars 5).
- Pull part A backward keeping it slightly raised to avoid damaging the disk 6) on blast tube 7).

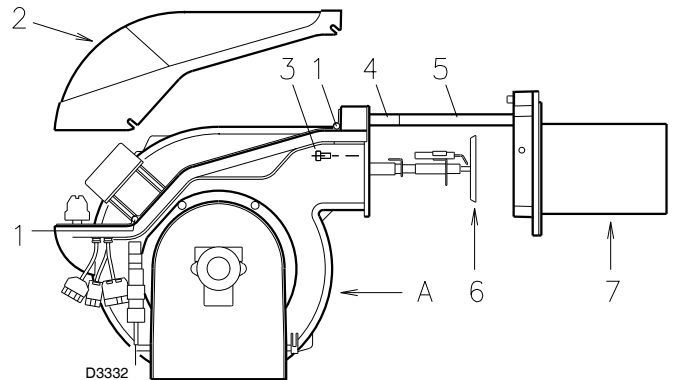

Fig. 30

8.4 Closing the burner

Refit following the steps described but in reverse order; refit all burner components as they were originally assembled.

8.5 Burner start-up cycle diagnostics

During start-up, indication is according to the Tab. I:

Sequences	Colour code
Pre-purging	● ○ ● ○ ● ○ ● ○ ●
Ignition phase	● ○ ● ○ ● ○ ● ○ ●
Operation, flame ok	□ □ □ □ □ □ □ □ □
Operating with weak flame signal	□ ○ □ ○ □ ○ □ ○ □
Electrical supply lower than ~ 170V	● ▲ ● ▲ ● ▲ ● ▲ ●
Lock-out	▲ ▲ ▲ ▲ ▲ ▲ ▲ ▲ ▲
Extraneous light	▲ □ ▲ □ ▲ □ ▲ □ ▲

Key: ○ Off ● Yellow □ Green ▲ Red

Tab. I

8.6 Resetting the control box and using diagnostics

The control box features a diagnostics function through which any causes of malfunctioning are easily identified (indicator: **RED LED**).

To use this function, you must wait at least 10 seconds once it has entered the safety condition (lockout), and then press the reset button.

The control box generates a sequence of pulses (1 second apart), which is repeated at constant 3-second intervals.

Once you have seen how many times the light pulses and identified the possible cause, the system must be reset by holding the button down for between 1 and 3 seconds.



The methods that can be used to reset the control box and use diagnostics are given below.

8.6.1 Resetting the control box

- To reset the control box, proceed as follows:
- Hold the button down for between 1 and 3 seconds. The burner restarts after a 2-second pause once the button is released. If the burner does not restart, you must make sure the limit thermostat is closed.

8.6.2 Visual diagnostics

- Indicates the type of burner malfunction causing lockout.
- To view diagnostics, proceed as follows:
- Hold the button down for more than 3 seconds once the red LED (burner lockout) remains steadily lit. A yellow light pulses to tell you the operation is done. Release the button once the light pulses. The number of times it pulses tells you the cause of the malfunction, according to the coding system indicated in the table on page 28.

8.6.3 Software diagnostics

Reports burner life by means of an optical link with the PC, indicating hours of operation, number and type of lock-outs, serial number of control box etc ...

- To view diagnostics, proceed as follows:
- Hold the button down for more than 3 seconds once the red LED (burner lockout) remains steadily lit. A yellow light pulses to tell you the operation is done. Release the button for 1 second and then press again for over 3 seconds until the yellow light pulses again. Once the button is released, the red LED will flash intermittently with a higher frequency: only now can the optical link be activated.

Once the operations are done, the control box's initial state must be restored using the resetting procedure described above.

BUTTON PRESSED FOR	CONTROL BOX STATUS
Between 1 and 3 seconds	Control box reset without viewing visual diagnostics.
More than 3 seconds	Visual diagnostics of lockout condition: (Led pulses at 1-second intervals).
More than 3 seconds starting from the visual diagnostics condition	Software diagnostics by means of optical interface and PC (hours of operation, malfunctions etc. can be viewed)

The sequence of pulses issued by the control box identifies the possible types of malfunction, which are listed in the table on page 28.

9 Faults - Possible causes - Solutions

Find a list of faults, causes and possible solutions for a set of failures that may occur and result in irregular burner operation or no functioning at all.

If a burner malfunction is detected, first of all:

- check that the electrical wiring is adequately connected;
- check whether fuel is delivered;
- check that every adjustment parameter is adequately set.

SIGNAL	FAULT	POSSIBLE CAUSE	SOLUTION
No blink	The burner does not start	No electrical power supply	Close all switches - Check fuses
		A limit or safety control device is open	Adjust or replace
		Control box lock-out	Reset control box (no sooner than 10 s after the lockout)
		Pump is jammed	Replace
		Erroneous electrical connections	Check connections
		Defective control box	Replace
		Defective electrical motor	Replace
2 pulses ●●	After pre-purge and the safety time, the burner goes to lockout at the end of the safety time	No fuel in tank; water on tank bottom	Top up fuel level or suck up water
		Inappropriate head and air damper adjustments	Adjust
		Fuel solenoid valves fail to open (1st stage or safety)	Check connections; replace coil
		1st nozzle clogged, dirty, or deformed	Replace
		Dirty or poorly adjusted firing electrodes	Adjust or clean
		Grounded electrode due to broken insulation	Replace
		High voltage cable defective or grounded	Replace
		High voltage cable deformed by high temperature	Replace and protect
		Ignition transformer defective	Replace
		Erroneous valves or transformer electrical connections	Check
		Defective control box	Replace
		Pump unprimed	Prime pump
		Pump/motor coupling broken	Replace
		Pump suction line connected to return line	Correct connection
		Valves up-line from pump closed	Open
		Filters dirty: line - pump - nozzle	Clean
		Defective photocell or control box	Replace photocell or control box
		Photocell dirty	Clean
		1st stage operation of cylinder is faulty	Change the cylinder
		Motor lockout	Reset thermal relay
Defective motor command remote control device	Substitute it		
2-phase power supply thermal relay trips	Reset thermal relay		
Incorrect motor rotation direction	Change motor electrical connections		
4 pulses ●●●●	The burner starts and then goes into lockout	Photocell short-circuit	Replace photocell
		Light is entering or flame is simulated	Eliminate light or replace control box
7 pulses ●●●●●●●	Flame detachment	Poorly adjusted head	Adjust
		Poorly adjusted or dirty firing electrodes	Adjust
		Poorly adjusted fan air gate: too much air	Adjust
		1st nozzle is too big (pulsation)	Reduce 1st nozzle delivery
		1st nozzle is too small (flame detachment)	Increase 1st nozzle delivery
		1st nozzle dirty, or deformed	Replace
		Pump pressure not suitable	Adjust it: between 10 - 14 bar
		1st stage nozzle unsuited to burner or boiler	See Nozzle Table; reduce 1st stage nozzle
		Defective 1st stage nozzle	Replace

SIGNAL	FAULT	POSSIBLE CAUSE	SOLUTION
	The burner does not pass to 2nd stage	Control device TR does not close	Adjust or replace
		Defective control box	Replace
		2nd stage solenoid valve coil defective	Replace
		Piston jammed in valve unit	Replace entire unit
	Fuel passes to 2nd stage but air remains in 1st	Low pump pressure	Increase
		2nd stage operation of cylinder is faulty	Change cylinder
	Burner stops at transition between 1st and 2nd stage. Burner repeats starting cycle.	Nozzle dirty	Renew nozzle
		Photocell dirty	Clean
		Excess air	Reduce
	Uneven fuel supply	Check if cause is in pump from tank or fuel supply system	Feed burner located near burner
	Internally rusted pump	Water in tank	Suck water from tank bottom with separate pump
	Noisy pump, unstable pressure	Air has entered the suction line	Tighten connectors
		- Depression value too high (higher than 35 cm Hg):	
		Tank/burner height difference too great	Feed burner with loop circuit
		Piping diameter too small	Increase
		Suction filters clogged	Clean
		Suction valves closed	Open
		Paraffin solidified due to low temperature	Add additive to fuel
	Pump unprimes after prolonged pause	Return pipe not immersed in fuel	Bring to same height as suction pipe
		Air enters suction piping	Tighten connectors
	Pump leaks fuel	Leakage from sealing organ	Replace pump
	Smoke in flame - dark Bacharach	Not enough air	Adjust head and fan air damper
		Nozzle worn or dirty	Replace
		Nozzle filter clogged	Clean or replace
		Erroneous pump pressure	Adjust to between 10 - 14 bar
		Flame stability disc dirty, loose, or deformed	Clean, tighten in place, or replace
		Boiler room air vents insufficient	Increase
	- yellow Bacharach	Too much air	Adjust head and fan air damper
	Dirty combustion head	Nozzle or filter dirty	Replace
		Unsuitable nozzle delivery or angle	See recommended nozzles
		Loose nozzle	Tighten
		Impurities on flame stability spiral	Clean
		Erroneous head adjustment or not enough air	Adjust; open gate valve
		Blast tube length unsuited to boiler	Contact boiler manufacturer
10 pulses 		Connection or internal fault	
		Presence of electromagnetic disturbance	Use the radio disturbance protection kit

A Appendix - Accessories (optional)

EXTENDED HEAD KIT

“Standard head” burners can be transformed into “extended head” versions, by using the special kit. The kits available for the various burners, giving the original and the extended lengths, are listed below.

Burner	Code
RL 190	3010444

SOUND PROOFING BOX

If noise emission needs reducing even further, sound-proofing boxes is available.

Burner	Box type	Average noise reduction [dB(A)]	Code
RL 190	C4/5	10	3010404

DEGASSING UNIT

It may occur that a certain amount of air is contained in the fuel sucked up by the pump.

This air may originate from the fuel itself as a consequence of de-pressurisation or air leaking past imperfect seals.

In double-pipe systems, the air returns to the tank from the return pipe; in single-pipe systems, the air remains in circulation causing pressure variations in the pump and burner malfunctions.

For this reason, we advise installing a degassing unit near the burner in single-pipe installations.

Degassing units are provided in two versions:

Burner	Code
RL 190 (without filter)	20034277
RL 190 (with filter)	20034281

Degassing unit characteristics

Burner output	80 kg/h max
Fuel pressure	0.7 bar max
Ambient temperature	40 °C max
Fuel temperature	40 °C max
Attachment connectors (without filter)	FF G 1/4 tank side FM G 3/8 conic burner side
Attachment connectors (with filter)	FF G 3/8 tank side FM G3/8 conic burner side

PROTECTION KIT (ELECTROMAGNETIC INTERFERENCES)

When the burner is installed in a room particularly subject to electromagnetic interference (signals emitted over 10 V/m) due for example to INVERTER presence or in systems where the lengths of the thermostat connections is over 20 meters, this specific protection kit is available as an interface between the thermostatic controls and the burner..

Burner	Code
RL 190	3010386

PC INTERFACE KIT

To connect the control box to a personal computer for the transmission of operation, fault signals and detailed service information, an interface adapter with PC software are available.

Burner	Code
RL 190	3002719

SPACER KIT

If burner head penetration into the combustion chamber needs reducing, varying thickness spacers are available, as given in the following table.

Burner	Code
RL 190	3000722

STATUS PANEL KIT

The electronic device “Status Panel” continuously monitors and displays all the burner operational modes and picks up any anomalies during the operational cycle.

Burner	Code
RL 190	3010322

Status assembly

The burners are preset to accept the Status. To assemble, proceed as follows:

- connect Status 1)(Fig. 1) using connector 2) fitted on the bracket 3);
- fasten Status to the bracket using the screws 4) supplied with the kit.

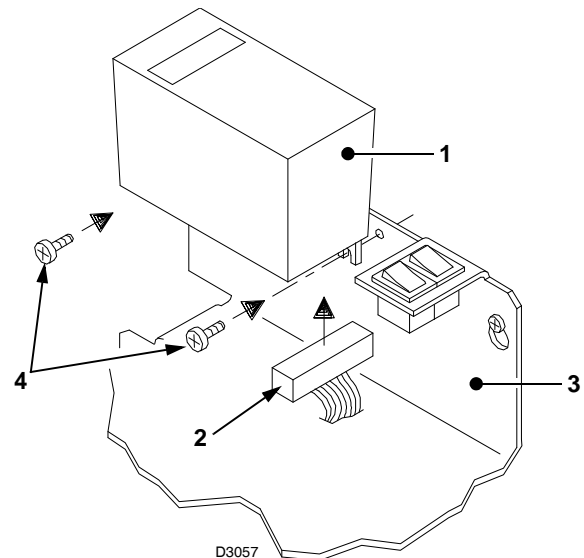

Fig. 1

The STATUS unit has three functions:

1 BURNER OPERATING HOURS AND THE NUMBER OF FIRINGS ARE SHOWN ON DISPLAY V

Total operating hours

Press button "h1".

2nd stage operating hours

Press button "h2".

1st stage operating hours

Total hours - 2nd stage operating hours

Number of firings

Press button "count".

Resetting operating hours and number of firings

Press the three "reset" buttons simultaneously.

Non-volatile memory

The operating hours and the number of firings will remain in the memory even in the case of electrical power failures.

2 INDICATES THE TIMES RELATIVE TO THE FIRING STAGE

The leds illuminate in the following sequence, see A)(Fig. 2):

WITH CONTROL DEVICE TR CLOSED

- 1 Burner off, TL open
- 2 Control device TL closed
- 3 Motor start: seconds count starts on read-out V
- 4 1st stage valve energized
- 5 2nd stage valve energized: seconds count stops on read-out V
- 6 10 seconds after stage 5 the code I I I I will appear on the read-out: this indicates that the starting phase is terminated.

WITH CONTROL DEVICE TR OPEN

- 1 Burner off, TL open
- 2 Control device TL closed
- 3 Motor start: seconds count starts on read-out V
- 4 1st stage valve energized
- 7 30 seconds after stage 4: seconds count stops on read-out V
- 8 10 seconds after stage 7 the code I I I I will appear on the read-out: this indicates that the starting phase is terminated.

The times, in seconds, shown on read-out V, indicate the succession of the various starting stages.

3 IN THE CASE OF BURNER MALFUNCTIONS, THE STATUS PANEL INDICATES THE EXACT TIME AT WHICH THE FAULT OCCURRED

There are 3 possible combinations of illuminated leds, see B)(Fig. 2).

For the causes of the malfunction refer to the instruction manual.

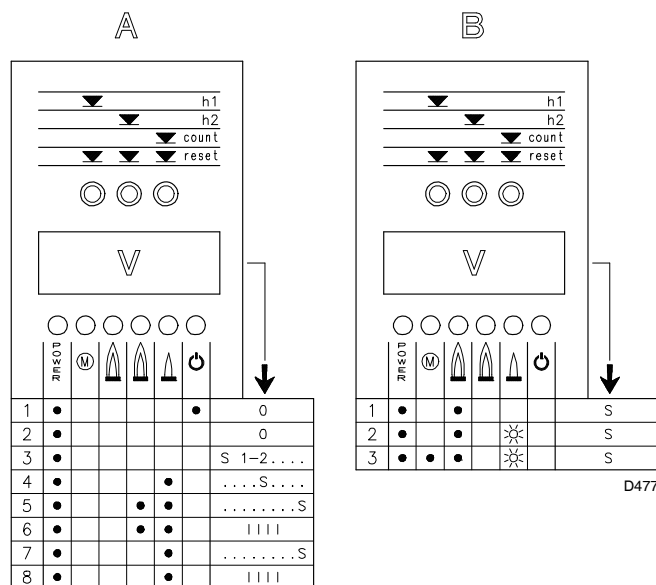

- ☼ = Led flashing
- = Led illuminated
- S = Time in seconds
- IIII = Burner start cycle terminated

Key to symbols:

- POWER Power on
- (M) Fan motor blocked (red color)
- (flame) Burner lock-out (red color)
- (flame) 2nd stage operation
- (flame) 1st stage operation
- (power) Load level reached (Stand-by), led on

Fig. 2

B Appendix - Electrical panel layout

ELECTRICAL EQUIPMENT FACTORY-SET

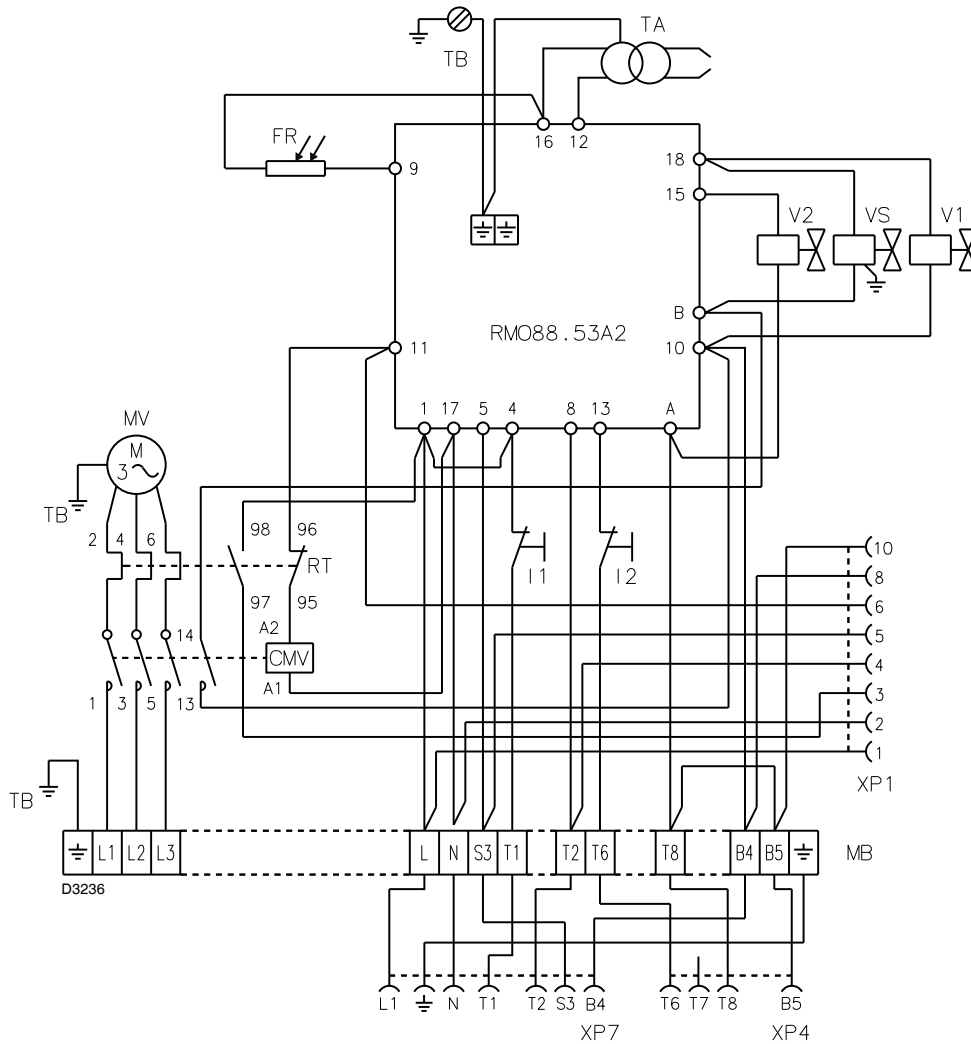

Fig. 3



WARNING

The burner leave the factory preset for **400V** power supply.

If **230V** power supply is used, change the motor connection from star to delta and change the setting of the thermal cut-out as well.

For remote-reset, connect a push-button switch (NO) between terminal 3 and neutral of the control box (terminals 15, 16, 17 and 18).

TO BE COMPLETED BY THE INSTALLER

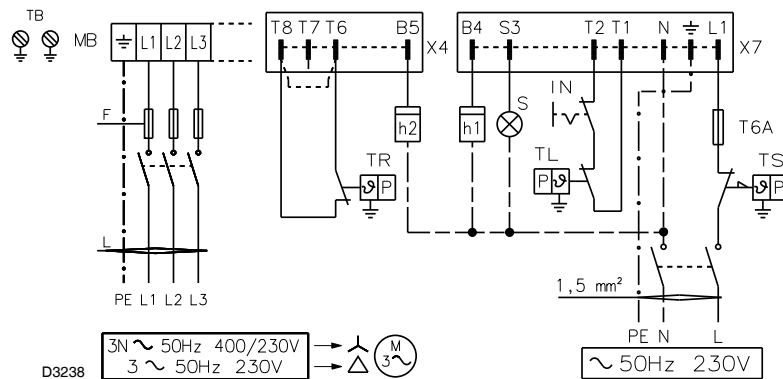

Fig. 4



WARNING

The burner is factory set for two-stage operation and it must therefore be connected to the TR remove control device to command light oil valve V2. Alternatively, if single stage operation is required, instead of control device TR install a jumper lead between terminal 11 and 12 of the terminal strip.

Key to layout

CMV	Motor contactor
FR	Photoresistor
I1	Switch: burner off - on
I2	Switch: 1 st - 2 nd stage operation
MB	Terminal strip
MV	Fan motor
RMO...	Control box
RT	Thermal cut-out
TA	Ignition transformer
TB	Burner ground (earth) connection
V1	1st stage solenoid valve
V2	2 nd stage solenoid valve
VS	Safety solenoid valve
XP1	Connector for STATUS
XP4	4 pole socket
XP7	7 pole socket
H1	1 st stage hourcounter
H2	2 nd stage hourcounter
IN	Manual burner stop switch
MB	Terminal strip
S	Remote lock-out signal
TB	Burner ground (earth) connection
TL	Limit control device system: this shuts down the burner when the boiler temperature or pressure exceeds the setpoint value.
TR	High-low mode control device system: this controls operating stages 1 and 2 and is necessary only for two-stage operation.
TS	Safety control device system: this operates when TL is faulty.
X4	4 pole plug
X7	7 pole plug



RIELLO S.p.A.
I-37045 Legnago (VR)
Tel.: +39.0442.630111
[http:// www.rielloburners.com](http://www.rielloburners.com)