

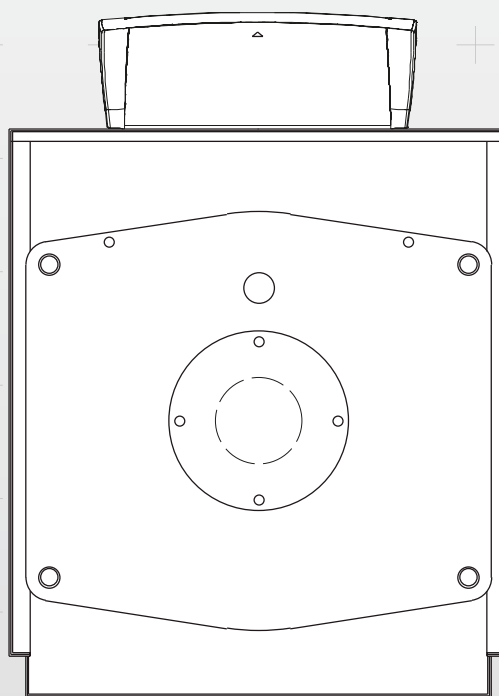

EN

PRESSURISED STEEL BOILERS

REX 7 ÷ 130



INSTALLATION, USE AND MAINTENANCE MANUAL



INDEX

General information

- 3 Introduction
- 3 Range
- 3 Compliance
- 3 Warranty
- 4 Warnings
- 4 Prohibitions
- 5 Hazards
- 5 Identification
- 6 Appliance description
- 6 Structure
- 7 Optional control panel
- 8 Dimensions and connections
- 9 Technical data
- 10 Technical data
- 11 Control panel
- 11 Burners

Boiler welding

- 12 Product receipt
- 13 Handling
- 13 Installation room
- 14 System cleaning
- 14 Hydraulic connections
- 14 Starting hydraulic circuit
- 15 Flue gas discharge and combustion air suction
- 16 Front door opening
- 17 Front door adjustment
- 17 Turbulator assembly
- 18 Insulating casing assembly
- 19 Bulb fastening
- 20 Burner assembly
- 20 Electrical connections
- 21 Water treatment
- 22 System filling and emptying

Use

- 23 Preliminary checks
- 23 Commissioning
- 23 Checks after commissioning
- 25 Stop periods
- 25 Decommissioning of old appliances

Maintenance

- 26 Boiler
- 27 Burner
- 28 Any anomalies and remedies
- 28 Environmental protection and disposal
- 29 Exploded views of drawings

Useful information and declarations

- 30 QR code
- 31 Declaration of Conformity

Notes

SYMBOLS USED IN THE MANUAL



DANGER

To indicate actions that, if not performed correctly, can result in injury of generic origin or may generate malfunction or damage to the appliance; therefore require particular caution and adequate preparation.



IT IS FORBIDDEN

To indicate operations that SHOULD NOT be performed.



IMPORTANT

To indicate particularly useful information and important.

The illustrations and data presented are not binding. The company reserves the right to make without prior notice any changes it deems appropriate for continuous improvement and constant updating.

1 General information

INTRODUCTION

Dear Customer,

Thank you for having chosen an appliance of the series **REX**, a high quality and efficiency product, reliable and safe.

We recommend entrusting its maintenance to **Professionally Qualified Personnel** who, when necessary, uses original spare parts.

This manual contains important information and suggestions that must be observed for easier installation and best possible use of the appliance.



IMPORTANT

Failure to observe the instructions in this manual will void the warranty conditions.

RANGE

MODEL	CODE
REX 7*	83801010
REX 8*	83801020
REX 9*	83802010
REX 10*	83802020
REX 12*	83802030
REX 15*	83803010
REX 20*	83803020
REX 25*	83804010
REX 30*	83805010
REX 35*	83806010
REX 40	83807010
REX 50	83808010
REX 62	83809010
REX 75	83810010
REX 85	83810020
REX 95	83811010
REX 100	83812010
REX 120	83812020
REX 130	83812030

* Product not compliant with the requirements set out in the European regulations No. 811-813/2013 and therefore not suitable for the installation on the EU territory for plant rooms or produce domestic hot water.

The product can only be supplied for installations in non-EU countries for any application

COMPLIANCE

REX boilers comply with the following European Directives:

- European Regulation on Gas Equipment GAR 2016/426/EU
- Low Voltage Directive 2014/35/EU
- Electromagnetic Compatibility Directive 2014/30/EU
- Efficiency Directive 92/42/EEC
- Energy efficiency ★★



NOTE

The serial number is indicated on the boiler technical nameplate.

WARRANTY

The warranty conditions for boilers series **REX** are included in the CONSTRUCTION - WARRANTY CERTIFICATE supplied with the product.

WARNINGS



IMPORTANT

- The appliance must be used for the purposes for which it has been expressly designed and any manufacturer's liability shall be excluded in case of damage to persons, animals or property due to insufficient maintenance or improper use.
- This manual is an integral part of the boiler and must be carefully read before installation and commissioning of the appliance. Moreover, it must be carefully stored for subsequent consultations and must ALWAYS accompany the boiler during its entire life-cycle (from installation to disposal). In case of damage or loss, request a copy from **ICI CALDAIE S.p.A.** Technical Assistance Service.
- The appliance is delivered in several separated packages. Upon receipt, check that the supply is intact and undamaged and promptly contact the **ICI CALDAIE S.p.A.** if it does not correspond to the order.
- The installation of **REX** boilers must be performed by a Certified Body which, at the end of the operation, must provide the owner with the declaration of conformity certifying that the installation has been correctly carried out, namely in compliance with the Standards and the national and local Laws in force, and with the indications included in the instruction manuals supplied by **ICI CALDAIE S.p.A.**
- The maintenance of the appliance is a legislative obligation. The User must have it carried out by an Authorised Company or by qualified personnel (maintenance technician) in compliance with the requirements of the local Standards in force.
- Ordinary and extraordinary maintenance must be carried out by qualified personnel in order to promptly detect any damage to the boiler body under pressure and to the safety and control accessories.
- The boiler is used to heat water at a temperature lower than the boiling temperature at atmospheric pressure and must be connected to a heating and/or domestic hot water production system, within the limits of its performance and power.

PROHIBITIONS



IT IS FORBIDDEN

- Operate electrical devices or appliances such as switches, household appliances, etc. if you smell fuel or unburnt materials.
In this case:
 - ventilate the room by opening doors and windows
 - close the fuel shut-off device
 - ask the Technical Assistance Service or qualified personnel to intervene as soon as possible.
- Any technical or cleaning operation carried out before disconnecting the appliance from the power supply mains, by positioning the system main switch and the control panel main switch to "OFF".
- Modifying safety or adjustment devices without the boiler manufacturer's authorisation and indications.
- Plug or dimensionally reduce the ventilation openings of the installation room. The ventilation openings are essential for proper combustion.
- Exposing the boiler to atmospheric agents. It is not designed to operate outdoor and it does not feature automatic anti-freeze systems.
- Leave flammable substances and containers in the room where the appliance is installed.
- Disperse the packaging material in the environment and leave it within the reach of children as it may be a potential source of danger. It must be disposed of in accordance with the legislation in force.

HAZARDS



DANGER

- In case of water leakages, disconnect the boiler from the power supply mains, close the water supply and contact, as soon as possible, the Technical Assistance Service Authorised by **ICI CALDAIE S.p.A.** or qualified personnel.
- Sensing the presence of fuel in the thermal power plant, it is appropriate to follow the precautions below to avoid the risk of explosions and fires:
 - *do not smoke or cause sparks*
 - *do not turn on lights or electrical devices in general (mobile phones)*
 - *open doors and windows*
 - *close the fuel shut-off valve normally placed outside the thermal power plant*
 - *disconnect the power supply by means of the switch which is usually located outside of the plant room.*
- During the normal operation, the appliance has hot parts, such as the channel and the flue gas box, which in case of accidental contact without appropriate personal protection can cause severe burns.
- An incorrect adjustment of the closing door or an insufficient chimney draught can cause the presence of smoke inside the heating plant room, leading to fatal intoxications due to carbon monoxide, which is by nature colourless and odourless. Therefore, make sure that the boiler is correctly adjusted and installed and that the heating plant room features vents compliant with the standards in force.

IDENTIFICATION

Each **REX** boiler can be identified through the construction plate (1) inside the envelope of the documents supplied with the boiler, which includes technical/efficiency information such as:

- serial number or identification marking
- heat input in kW
- nominal thermal flow in kW
- types of fuels which can be used
- maximum operating pressure.
- CE marking



IMPORTANT

The boiler installer **MUST** apply the construction plate, at the end of installation, in the front upper side of one of the side panels of the cover, so that it can be easily identified and read. In case of loss, request a copy to the Technical Assistance Service of **ICI CALDAIE S.p.A.** providing the serial number indicated in the CONSTRUCTION CERTIFICATE - WARRANTY or the sale delivery note.

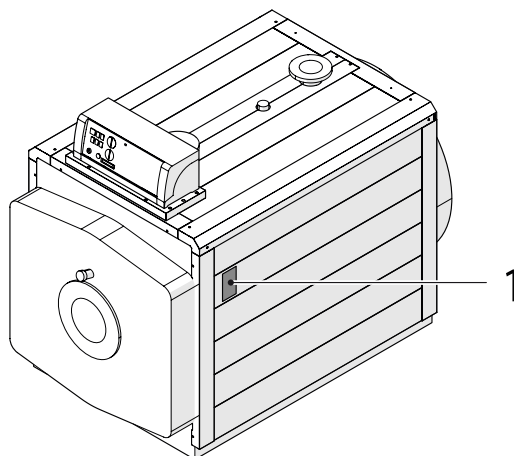

The appliance is also accompanied by **construction certificate** attesting the successful result of the hydraulic test.



IMPORTANT

The installation must be performed in compliance with the local standards by **qualified personnel**, namely by personnel with specific technical skills in the field of the heating system components. An incorrect installation may cause damage to persons or property for which the manufacturer will not be liable.

During **commissioning** check the effectiveness of all adjustment and control devices in the control panel.

The **warranty** validity is subject to compliance with the instructions in this manual.

APPLIANCE DESCRIPTION

High-efficiency **ICI CALDAIE S.p.A. REX** steel boilers must be used for heating systems with water temperature within 60° and 100°C and/or in a system for domestic hot water production, within the limits of their performance and power.

The chosen control panel should be equipped with a safety thermostat with manual reset from 110°C.

They have been provided with cylindrical furnace with reverse flame closed at the back by a fully wet convex bottom, supported by a stub and that can be coupled with forced draft burners.

Some of the main characteristics of the equipment are listed below:

- boiler body made in quality steel, made up by the front tube plate flanged towards the furnace with RSB process and by the convex, instead of flat, rear plate, for better resistance to the internal pressure, with laser-cut holes
- cylindrical combustion chamber, with reverse flame, closed at the back with fully wet convex bottom, supported by a stub. The flame runs through the central part, while the hot gases return peripherally to the front, partially wet, part to be conveyed to the tube bundle
- EN10217-2 P235GH fire tubes, welded to the front and rear tube plates, equipped with helical turbulators
- rear smokebox made in steel metal sheet, consisting of a single piece that can be easily opened to inspect the fire tubes, fastened by means of bolts, complete with chimney fitting and cleaning door
- containment tube bundle equipped with connections necessary for the system and the operating equipment, all welded with approved processes carried out by qualified welders
- casing made with easily removable painted steel panels, that protect the insulation made with high-density fibreglass wool mats
- front door made in steel metal sheet thermally insulated with ceramic fibre, fitted on hinges, that can be easily opened by means of drilled ring nuts and with supplied lever.

STRUCTURE

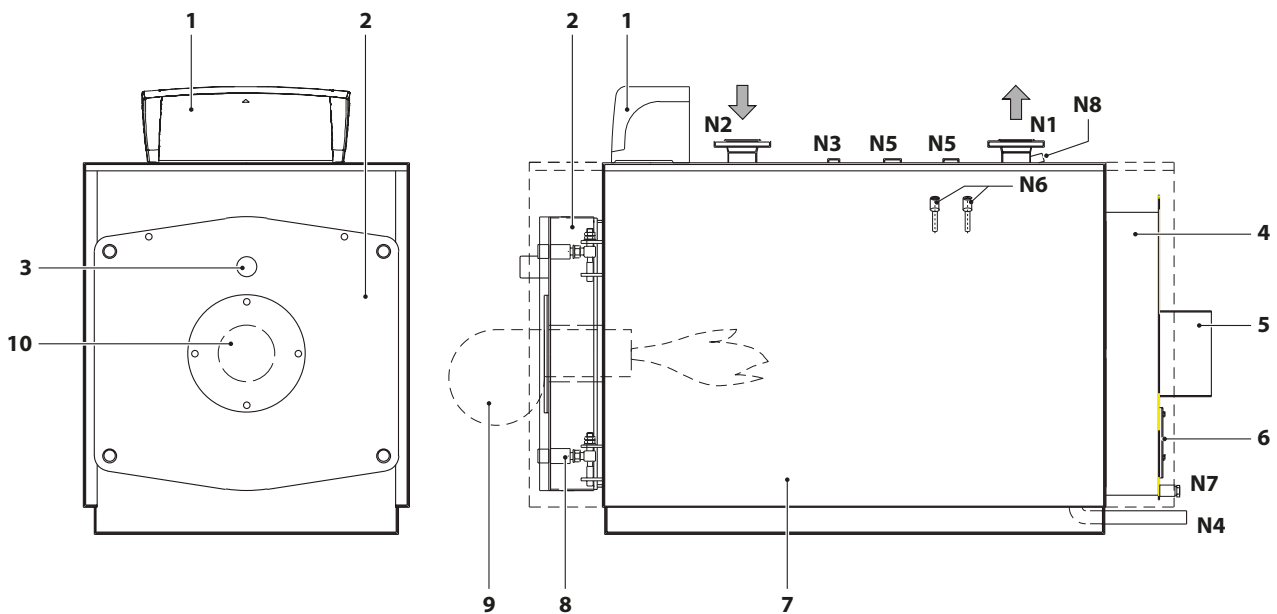

- 1 Control panel (accessory)
- 2 Front door
- 3 Flame inspection window
- 4 Rear smokebox
- 5 Flue gas drain fitting
- 6 Inspection door
- 7 Insulating casing
- 8 Door hinges
- 9 Burner (accessory)
- 10 Burner support flange

- N1 Boiler flow fitting
- N2 Boiler return fitting
- N3 Instruments fitting
- N4 System intake/drain fitting
- N5 Safety valve(s) fitting
- N6 Bulb-holder pockets
- N7 Condensate drain fitting
- N8 Control pocket

OPTIONAL CONTROL PANEL

The (optional) control panel, made of plastic with protection grade IP40, contains the regulation and safety instruments:

The upper casing of the control panel can rotate to access the terminal board and unwind the capillary tubes of thermostats and thermometers.

The regulation thermostats have an operating range from 60°C to 100°C and can be calibrated by the user by means of the front knob.

The safety thermostat has a fixed calibration of 110°C and a manual reset as required by the regulations.

The circulation pump enabling thermostat located inside the panel can be adjusted from 0°C to 90°C with a tool and is factory-set to 50°C, its activation differential is 6°C. Thanks to this thermostat, the circulation pump remains stopped when the temperature is lower than 50°C to avoid the hazardous flue gas condensation.

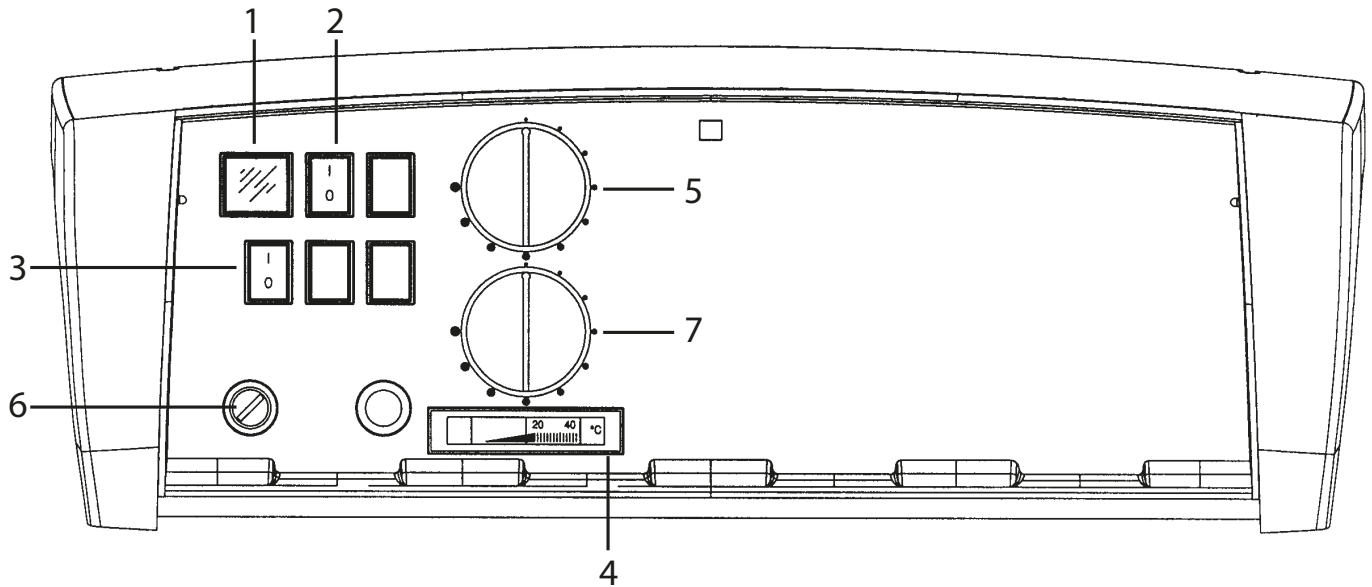

KEY

- 1 NETWORK LIGHT
- 2 BURNER SWITCH NO. 1
- 3 SYSTEM CIRCULATION PUMP SWITCH
- 4 BOILER THERMOMETER
- 5 LIMIT REGULATION THERMOSTAT
- 6 SAFETY THERMOSTAT
- 7 HIGH/LOW FLAME THERMOSTAT

WIRING DIAGRAM

See the diagram inside the electric panel.

DIMENSIONS AND CONNECTIONS

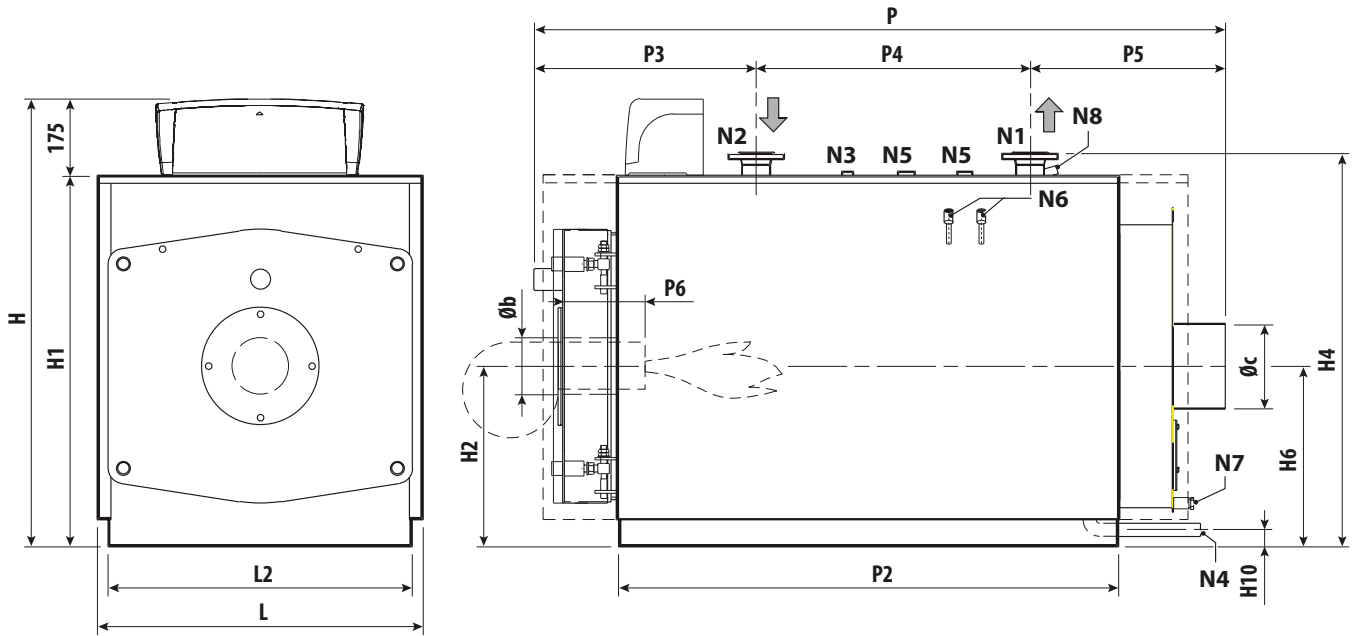

Dimensions

Description	u.m.	REX																		
		7*	8*	9*	10*	12*	15*	20*	25*	30*	35*	40	50	62	75	85	95	100	120	130
H	mm	1063	1063	1030	1030	1030	1080	1080	1080	1180	1180	1190	1380	1380	1510	1510	1510	1660	1660	1660
H1	mm	853	853	855	855	855	905	905	905	1005	1005	1015	1205	1205	1335	1335	1335	1485	1485	1485
H2	mm	415	415	415	415	415	440	440	440	490	490	500	610	610	675	675	675	750	750	750
H4	mm	912	912	912	912	912	962	962	962	1061	1061	1095	1285	1285	1417	1417	1417	1568	1568	1568
H6	mm	415	415	415	415	415	440	440	440	490	490	500	610	610	675	675	675	750	750	750
H10	mm	54,5	54,5	54,5	54,5	54,5	54,5	54,5	54,5	54,5	54,5	50	60	60	60	60	60	60	60	60
L	mm	756	756	756	756	756	806	806	806	906	906	946	1166	1166	1296	1296	1296	1446	1446	1446
L2	mm	700	700	700	700	700	750	750	750	850	850	890	1110	1110	1240	1240	1240	1390	1390	1390
P	mm	994	994	1119	1119	1119	1364	1364	1614	1614	1864	1872	1946	2235	2247	2247	2497	2477	2477	2477
P2	mm	630	630	755	755	755	1000	1000	1250	1250	1500	1502	1502	1792	1753	1753	2003	2003	2003	2003
P3	mm	413	413	513	513	513	513	513	523	523	600	663	663	704	704	704	703	703	703	703
P4	mm	240	240	265	265	265	475	475	725	700	980	850	850	1150	1100	1100	1200	1200	1200	1200
P5	mm	341	341	341	341	341	376	376	376	391	361	422	433	422	443	443	593	574	574	574
P6	mm	200-250	200-250	200-250	200-250	200-250	200-250	200-250	200-250	200-250	200-250	230-280	270-320	270-320	270-320	270-320	270-320	270-320	270-320	270-320
Øb	mm	130	130	130	130	130	160	160	160	180	180	225	225	225	280	280	280	280	280	280
Øc	mm	200	200	200	200	200	250	250	250	250	250	250	300	300	350	350	350	400	400	400

For BIOGAS generators, add 40 mm to measurement P6

Attachments

Description	u.m.	REX																		
		7*	8*	9*	10*	12*	15*	20*	25*	30*	35*	40	50	62	75	85	95	100	120	130
N1	DN/in	50	50	50	50	50	50	50	50	65	65	80	80	80	100	100	100	125	125	125
N2	DN/in	50	50	50	50	50	50	50	50	65	65	80	80	80	100	100	100	125	125	125
N1/N2	PN	6	6	6	6	6	6	6	6	6	6	6	6	6	6	6	6	6	6	6
N3	DN/in	1"	1"	1"	1"	1"	1"	1"	1"	1"	1"	1"	1"	1"	1"	1"	1"	1"	1"	1"
N4	DN/in	1"	1"	1"	1"	1"	1"	1"	1"	1"	1"	1 1/4"	1 1/4"	1 1/4"	1 1/4"	1 1/4"	1 1/4"	1 1/4"	1 1/4"	1 1/4"
N5	DN/in	-	-	-	-	-	-	-	-	-	1 1/4" (1)	1 1/4"	1 1/4"	1 1/4"	1 1/4"	1 1/4"	1 1/4"	1 1/4"	1 1/4"	
N6	DN/in	1/2"	1/2"	1/2"	1/2"	1/2"	1/2"	1/2"	1/2"	1/2"	1/2"	1/2"	1/2"	1/2"	1/2"	1/2"	1/2"	1/2"	1/2"	1/2"
N7	DN/in	1/2"	1/2"	1/2"	1/2"	1/2"	1/2"	1/2"	1/2"	1/2"	1/2"	1/2"	1/2"	1/2"	1/2"	1/2"	1/2"	1/2"	1/2"	1/2"
N8	DN/in	1/2"	1/2"	1/2"	1/2"	1/2"	1/2"	1/2"	1/2"	1/2"	1/2"	1/2"	1/2"	1/2"	1/2"	1/2"	1/2"	1/2"	1/2"	1/2"

(1) One single connection

TECHNICAL DATA

DESCRIPTION	u.m.	REX									
		7*	8*	9*	10*	12*	15*	20*	25*	30*	35*
Effective rated ^[1]	kW	70	80	90	100	120	150	200	250	300	350
Thermal capacity	kW	76	87	98	109	130	163	216	271	325	379
Efficiency at 100% (ref. P.C.I.) ^[1]	%	92,11	91,95	91,84	91,74	92,31	92,02	92,59	92,25	92,31	92,35
Efficiency of 100% (stars) ^[2]	%	**	**	**	**	**	**	**	**	**	**
Max gas flow rate - G20	Stm ³ /h	8,04	9,21	10,37	11,53	13,76	17,25	22,86	28,68	34,39	40,11
Max gas flow rate - G30	kg/h	5,97	6,83	7,7	8,56	10,21	12,8	16,96	21,28	25,53	29,77
Max gas flow rate - G31	kg/h	5,9	6,76	7,61	8,47	10,1	12,66	16,78	21,05	25,25	29,44
Max flue gas flow rate	kg/h	119,8	137,23	154,51	171,8	205,02	257,03	340,61	427,33	512,41	597,64
Efficiency at 30% (ref. N.C.V.) ^[1]	%	91,4	91,5	91,55	91,66	91,45	91,3	91,36	91,7	91,9	91,9
Pressure drops on exhaust side	mbar	0,8	1	0,8	1	1,1	1,2	1,9	2	2	2,9
Heat losses through the chimney	%	7,09	7,25	7,36	7,46	6,89	7,18	6,61	6,95	6,89	6,85
Heat losses through the casing	%	0,8	0,8	0,8	0,8	0,8	0,8	0,8	0,8	0,8	0,8
Heat losses with burner off	%	0,1	0,1	0,1	0,1	0,1	0,1	0,1	0,1	0,1	0,1
Flue gas temperature (Nom. output, air = 20°C) - GAS	°C	188	192	194	197	184	190	177	185	184	183
Flue gas temperature (Nom. output, air = 20°C) - OIL	°C	191	195	197	199	186	193	180	188	186	186
Flue gas temperature (Nom. output, air = 20°C) - FUEL OIL	°C	191	194	197	199	186	193	180	187	186	185
CO ₂ - GAS	%	10,5	10,5	10,5	10,5	10,5	10,5	10,5	10,5	10,5	10,5
CO ₂ - OIL	%	13,5	13,5	13,5	13,5	13,5	13,5	13,5	13,5	13,5	13,5
CO ₂ - FUEL OIL	%	14	14	14	14	14	14	14	14	14	14
Fluid pressure drop (ΔT=12K)	mbar	8	10	13	16	23	35	63	98	50	67
Rated pressure	bar	5	5	5	5	5	5	5	5	5	5
Total weight	Kg	216	216	258	258	258	346	346	431	475	542
Total capacity	l	105	105	123	123	123	172	172	220	300	356
Rated frequency ~ voltage	Volt ~ Hz	230 ~ 50	230 ~ 50	230 ~ 50	230 ~ 50	230 ~ 50	230 ~ 50	230 ~ 50	230 ~ 50	230 ~ 50	230 ~ 50
Electric protection rating	IP	40	40	40	40	40	40	40	40	40	40
Absorbed power ^[3]	W	20	20	20	20	20	20	20	20	20	20
Allowed fuels		Methane - LPG - Diesel - Naphtha									

^[1] Average temperature 70°C.

^[2] Efficiency Directive 92/42/EEC.

^[3] With electronic control unit (circulator and burner excluded).

* Product not compliant with the requirements set out in the European regulations No. 811-813/2013 and therefore not suitable for the installation on the EU territory for plant rooms or produce domestic hot water.

The product can only be supplied for installations in non-EU countries for any application

TECHNICAL DATA

DESCRIPTION	u.m.	REX								
		40	50	62	75	85	95	100	120	130
Effective rated ^[1]	kW	420	500	620	750	850	950	1020	1200	1300
Thermal capacity	kW	455	542	672	813	921	1030	1106	1301	1409
Efficiency at 100% (ref. P.C.I.) ^[1]	%	92,38	92,25	92,26	92,25	92,29	92,23	92,22	92,24	92,26
Efficiency of 100% (stars) ^[2]	%	**	-	-	-	-	-	-	-	-
Max gas flow rate - G20	Stm ³ /h	48,11	57,35	71,11	86,03	97,46	108,99	117,04	137,67	149,1
Max gas flow rate - G30	kg/h	35,71	42,57	52,78	63,85	72,33	80,89	86,86	102,18	110,66
Max gas flow rate - G31	kg/h	35,32	42,11	52,21	63,16	71,55	80,02	85,92	101,07	109,46
Max flue gas flow rate	kg/h	716,84	854,52	1059,54	1281,85	1452,15	1623,95	1743,9	2051,28	2221,59
Efficiency at 30% (ref. N.C.V.) ^[1]	%	91,8	91,9	91,8	91,8	91,8	91,7	91,9	91,8	91,7
Pressure drops on exhaust side	mbar	4,5	4,2	6,4	5,2	7,2	5,2	4	5,5	6,5
Heat losses through the chimney	%	6,82	6,95	6,94	6,95	6,91	6,97	6,98	6,96	6,94
Heat losses through the casing	%	0,8	0,8	0,8	0,8	0,8	0,8	0,8	0,8	0,8
Heat losses with burner off	%	0,1	0,1	0,1	0,1	0,1	0,1	0,1	0,1	0,1
Flue gas temperature (Nom. output, air = 20°C) - GAS	°C	182	185	185	185	184	185	186	185	185
Flue gas temperature (Nom. output, air = 20°C) - OIL	°C	185	188	188	188	187	188	189	188	188
Flue gas temperature (Nom. output, air = 20°C) - FUEL OIL	°C	184	187	187	187	187	188	188	188	187
CO ₂ - GAS	%	10,5	10,5	10,5	10,5	10,5	10,5	10,5	10,5	10,5
CO ₂ - OIL	%	13,5	13,5	13,5	13,5	13,5	13,5	13,5	13,5	13,5
CO ₂ - FUEL OIL	%	14	14	14	14	14	14	14	14	14
Fluid pressure drop (ΔT=12K)	mbar	42	60	92	55	71	89	42	58	68
Rated pressure	bar	5	5	5	5	5	5	5	5	5
Total weight	Kg	584	853	963	1205	1205	1417	1843	1843	1843
Total capacity	l	360	540	645	855	855	950	1200	1200	1200
Rated frequency ~ voltage	Volt ~ Hz	230 ~ 50	230 ~ 50	230 ~ 50	230 ~ 50	230 ~ 50	230 ~ 50	230 ~ 50	230 ~ 50	230 ~ 50
Electric protection rating	IP	40	40	40	40	40	40	40	40	40
Absorbed power ^[3]	W	20	20	20	20	20	20	20	20	20
Allowed fuels		Methane - LPG - Diesel - Naphtha								

^[1] Average temperature 70°C.

^[2] Efficiency Directive 92/42/EEC.

^[3] With electronic control unit (circulator and burner excluded).

CONTROL PANEL

The control panels which can be installed on **REX** boilers are mentioned in the table.

They must be ordered separately from the boiler and for to their technical and installation characteristics refer to the manual provided with the panel.

To choose the most appropriate control panel for the system refer also to the **CATALOGUE**, and to use it refer to the manual supplied with the control panel.

Description	Code
Thermostatic control panel	QACC10ELMCE
eterm boiler control panel	QETERM01CE
eterm system control board	QETERM02

BURNERS

The burners that can be installed on the **REX** boilers must be CE marked according to European Directives:

- European Regulation on Gas Equipment GAR 2016/426/EU
- Electromagnetic Compatibility Directive 2014/30/EU
- Low Voltage Directive 2014/35/EU
- Machinery Directive 2006/42/EC (for liquid fuel burners)

They must also be able to operate on boilers with flame inversion combustion chamber.

Since the optimal operation of the boiler depends on the correct selection of the burner and its adjustment, find below some points to take into account:

- The firing range of the burner must include the boiler operating point (flow-back pressure in combustion chamber considering the pressure at the base of the chimney as ZERO)
- the length of the combustion head must be adequate to the penetration into the combustion chamber provided by ICI and shown in the table
- the length and shape of the flame must be suitable to the flame inversion combustion chambers. The burner manufacturers have this information as they are required by certification.

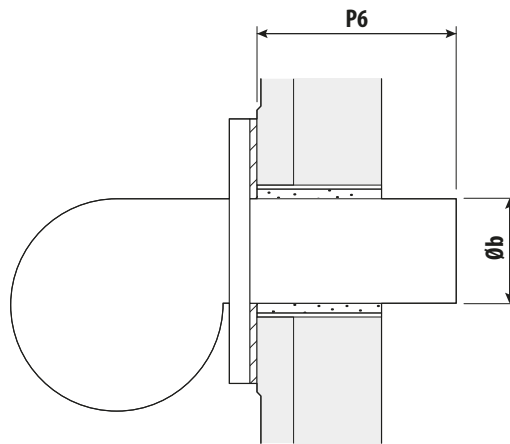

Description	U/M	REX																			
		7*	8*	9*	10*	12*	15*	20*	25*	30*	35*	40	50	62	75	85	95	100	120	130	
Øb	mm	130	130	130	130	130	160	160	160	180	180	225	225	225	280	280	280	280	280	280	280
P6	mm	200-250	200-250	200-250	200-250	200-250	200-250	200-250	200-250	200-250	200-250	230-280	270-320	270-320	270-320	270-320	270-320	270-320	270-320	270-320	270-320

2 Boiler welding

PRODUCT RECEIPT

The boilers are provided already covered with embossed aluminium with protective heat-shrink film.

- The document envelope (1) contains:
 - adhesive nameplate
 - instruction manual
 - construction certificate and warranty

Inside the combustion chamber there is the turbulator unit to be inserted in the fire tubes during boiler installation.

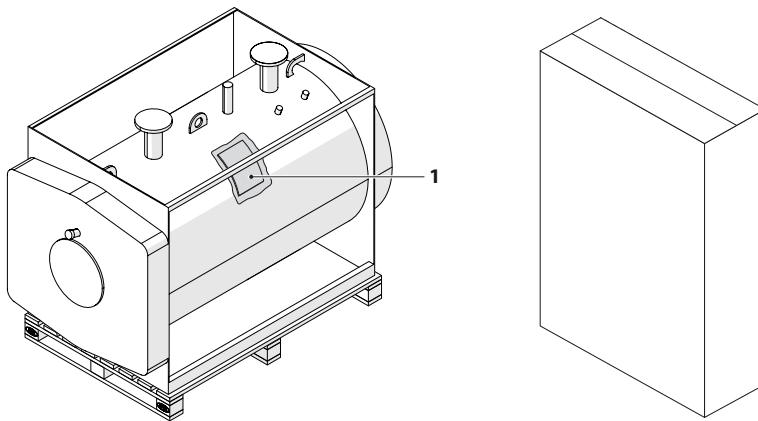

IMPORTANT

The instruction manual is an integral part of the appliance and it **MUST** be carefully read before installing and commissioning the boiler, carefully stored for further consultations and it **MUST** always accompany the boiler.



IMPORTANT

The control panel must be ordered separately from the boiler and is supplied in a separate package.



IMPORTANT

The mat of boilers from 7* to 40 is positioned outside the appliance: for all other models, it is inserted inside the combustion chamber.



IMPORTANT

PACKAGING: as for the package, **ICI CALDAIE S.p.A.** complies with the specific recycling systems of each country, ensuring an optimal reuse of them. All the materials used for the packaging respect the environment and can be recycled, such as wood, plastic, cardboard.

HANDLING

REX boilers are equipped with fittings for lifting operations and, in any case, they must be carefully moved with equipment suitable for their dimensions and weights.

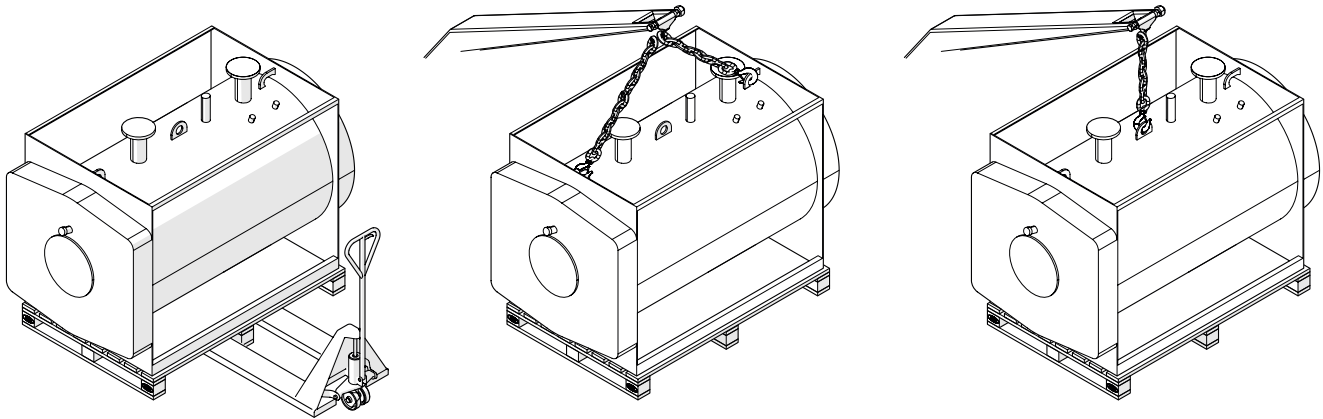

ATTENTION

The Personal Protective Equipment required by current legislation must be used.

INSTALLATION ROOM

The **REX** boiler installation room must be for exclusive use, meet the Technical Standards and Legislation in force and equipped with adequately sized ventilation openings.

The spaces around the boiler and towards the ceiling must be suitable for:

- installing the appliance
- reaching the safety devices
- maintenance
- repairing any breakage
- opening the door of the installed burner, considering its opening direction (towards the right or the left)

It is recommended to position the boiler, if possible, lifted from the floor to minimise dust extraction by the burner fan.

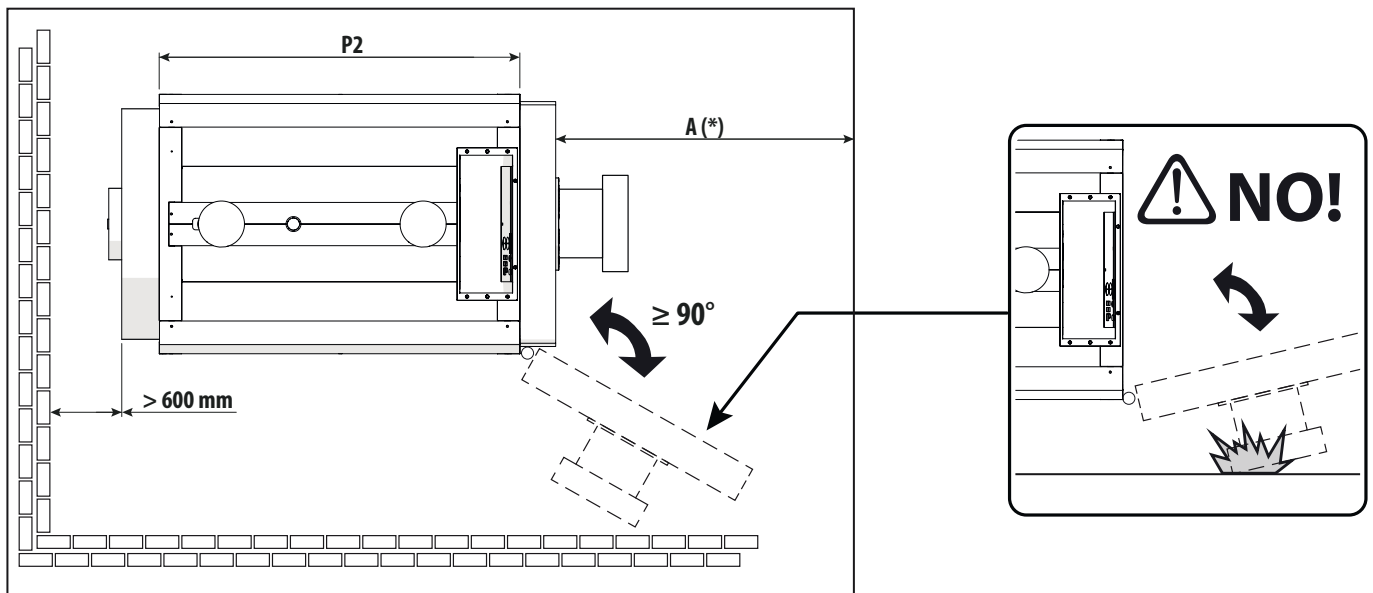

IMPORTANT

- The front space (A) must be greater than the boiler length to be able to extract the turbulators or replace a fire tube in case of breakage.
- In the case of several boilers installed in the same room, check the accessibility to the most remote boiler to be able to perform ordinary and extraordinary maintenance.



ATTENTION

- Consider the spaces necessary to access the adjustment and safety devices and to perform maintenance.
- If the burner is fed with gas of specific weight greater than that of the air, the electrical parts must be positioned at least 500 mm from the ground.

SYSTEM CLEANING

Before connecting the boiler to the system, it is RECOMMENDED to wash the pipes thoroughly in order to remove any residues which may compromise the correct operation of the boiler.

HYDRAULIC CONNECTIONS

STARTING HYDRAULIC CIRCUIT

The hydraulic circuit must be built by an authorised company or by qualified personnel, in compliance with the Technical Standards and the Law in force.

The components shall be charged to the installer that, at the end of the works, must issue a declaration of conformity.



IMPORTANT

ICI CALDAIE S.p.A. is not liable for any harm to people, animals or property damage caused by errors in the choice of components or in the construction of the plant.



IMPORTANT

- Make sure that the hydraulic pressure measured downstream of the pressure regulator on the supply line does not exceed the operating pressure indicated on the boiler nameplate.
- Make sure that the drains of the safety valves of the boiler and the heater, if any, are connected to a drain funnel, so that the valves do not flood the room in case of intervention.
- Make sure that the water and heating system pipes are not used as earthing point of the electrical system.
- Once the heating system has been filled, it is recommended to close the supply tap and keep it closed so that any system losses can be signalled by an hydraulic pressure drop detected on the system manometer.
- For reasons of technical expertise, the system components must be chosen and installed by the installer, that must operate in accordance with good practice regulations and Laws in force.

WATER CIRCULATION

The temperature difference between flow and return must not exceed 30°C in order to avoid thermal shocks to the boiler. The return temperature from the system must be higher than 50°C (with exclusive methane gas or LPG operation) in order to protect the boiler from corrosion due to acid flue gas condensate.

The warranty does not cover any damage caused by the condensate.

It is useful to mitigate the return temperature by installing a mixing valve and/or a recirculation pump.

FLUE GAS DISCHARGE AND COMBUSTION AIR SUCTION

The smoke duct and the connection to the chimney must be built in compliance with the Standards and the Laws in force, with rigid pipes, resistant to the temperature, condensate, mechanical stresses and sealed.



IMPORTANT

The smoke duct must have a diameter equal to or larger than the boiler fitting.

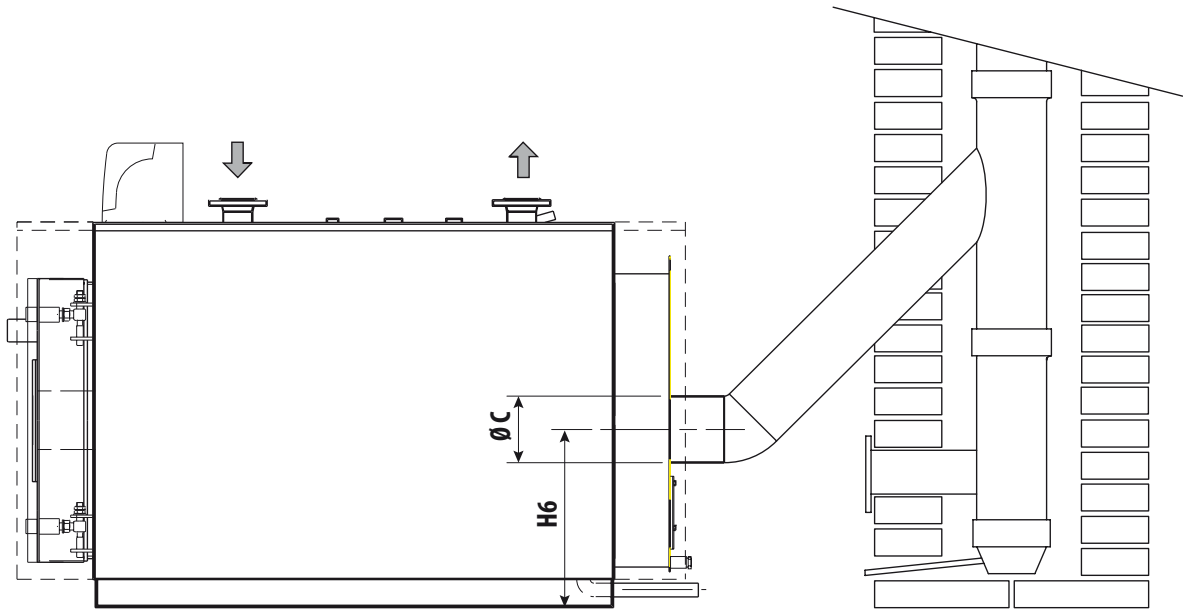

Description	u.m.	REX																		
		7*	8*	9*	10*	12*	15*	20*	25*	30*	35*	40	50	62	75	85	95	100	120	130
H6	mm	415	415	415	415	415	440	440	440	490	490	500	610	610	675	675	675	750	750	750
Ø C	mm	200	200	200	200	200	250	250	250	250	250	250	300	300	350	350	350	400	400	400



DANGER

- the chimney must ensure the draught necessary for the boiler operation and provided for by the Technical Standards in force, considering a "zero" pressure at the connection with the smoke duct
- unsuitable or badly dimensioned chimneys and smoke ducts can cause condensation problems and adversely affect the combustion parameters
- non-insulated drain pipes can lead to a potential risk and the tightness of the joints must be ensured with materials resistant to the temperatures of the drain flue gases (we recommend at least 250°C)
- check that the chimney has a suitable draught, does not feature chokes and is clear from debris; check that no drains of other equipment are connected to the chimney (unless this has been made to serve several utilities).

FRONT DOOR OPENING

The door is adjusted in the factory with standard opening to the left (Sx) and hinges on the right (Dx).



DANGER

It is DANGEROUS TO UNSCREW the ferrules (8) on the side of the hinges. This may cause the door to detach, with possible serious harm to people and property damage.

DOOR OPENING REVERSAL (TO THE RIGHT)

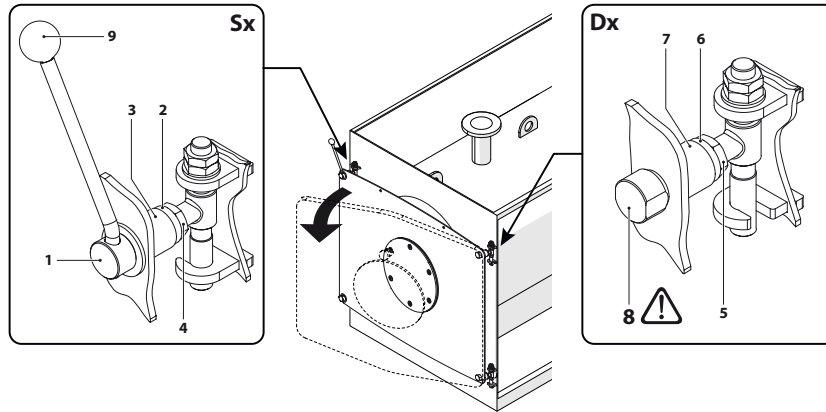

NOTE

The ferrules (8) can be "adjusted with wrench" or "perforated for lever adjustment".

DOOR WITH FERRULES PERFORATED ON BOTH SIDES

Proceed as follows to reverse the opening direction of the door:

- screw the left perforated ferrules (1) so that the door seal gasket is pressed in the same way as the right part. Bring the conical washers (2) of the left tie-rods close to the mechanical tubes (3) of the door and tighten the nuts (4) using a suitable wrench
- on the right opening side, loosen the nuts (5) and free the conical washers (6) from the mechanical tubes (7) of the door.

DOOR WITH WRENCH FERRULES, HINGE SIDE



DANGER

In models equipped with wrench-adjustable ferrules (8), these must always be mounted on the hinges to prevent the door from being accidentally opened through the lever (9).

Proceed as follows to reverse the opening direction of the door:

- screw the left perforated ferrules (1) so that the door seal gasket is pressed in the same way as the right part. Bring the conical washers (2) of the left tie-rods close to the mechanical tubes (3) of the door and tighten the nuts (4) using a suitable wrench
- cross-change the wrench ferrule of a hinge (8) with the opposite perforated ferrule (1), after loosening the locking nuts on the tie rods and freeing the conical washers
- on the left hinge side, fasten the conical washer (2) onto the door using the nut (4s)
- repeat the last two steps for the other two ferrules also.



DANGER

When cross-changing ferrules, always make sure that the other two ferrules are fastened, so that they hold the door.

Check the correct adjustment of the tie-rods and hinges ensuring that, during closure, the seal gasket is evenly pressed in the centre on the whole circumference. If necessary, adjust the door as described in the following paragraph.

FRONT DOOR ADJUSTMENT



DANGER

Incorrect door adjustment with consequent damage to people and property voids the warranty conditions.

DOOR ADJUSTMENT (OPENING ON THE RIGHT)

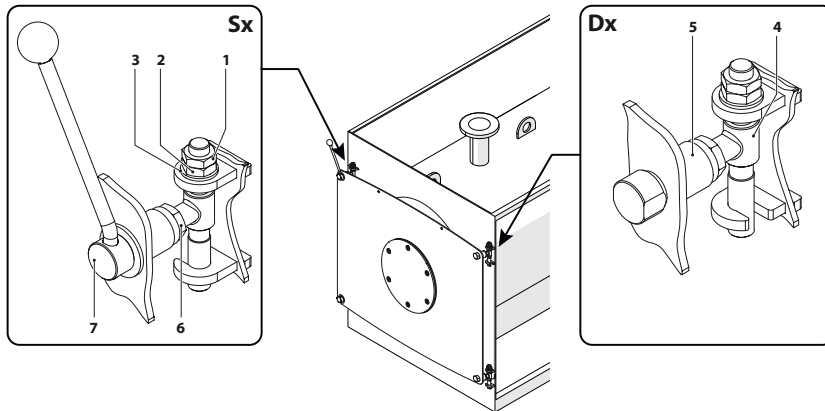

VERTICAL ADJUSTMENT

To make the adjustment:

- with the door ajar, loosen the counter-nuts (1) of the hinge units
- act on the adjustment nuts (2) to lift or lower the door by centring the gasket on the stop plate, then block the counter-nuts (1)
- close the door and centre the tie-rod (4) on the mechanical tube (5), proceeding as in the previous point.

HORIZONTAL ADJUSTMENT

Close the door using the lever and check that there is equal distance on both sides, between the stop plate and the band. If this is not the case:

- with the door ajar, loosen the locking nuts (6) of the hinge units
- act on the ferrule (7) to adjust the distance depth-wise
- screw the nuts (6) and block the conical washers on the mechanical tubes.



DANGER

When cross-changing ferrules, always make sure that the other two ferrules are fastened, so that they hold the door.

Check the proper adjustment in depth ensuring that the door, manually pushed up to the stop plate, naturally returns remaining ajar. This is to ensure the hinge side fume seal.

TURBULATOR ASSEMBLY

To assemble the turbulators supplied with the boiler, open the door and insert the turbulators completely into the smoke pipes, until they penetrate by at least 100 m.

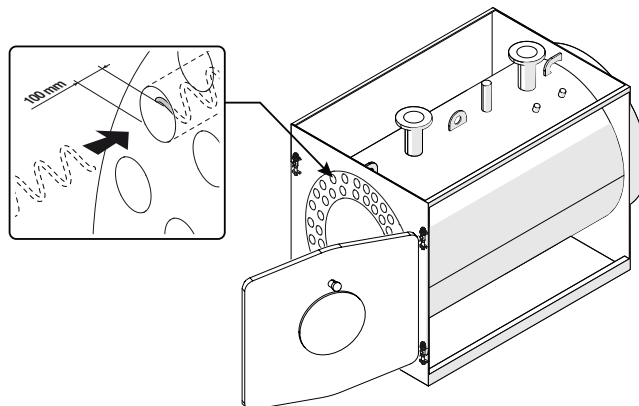

DANGER

The turbulators have very pointed and sharp ends. Therefore, wear suitable protective gloves during insertion (equipment according to current regulation).

INSULATING CASING ASSEMBLY

To fit the insulating casing proceed as follows:

- wrap the heat insulating mat around the boiler body and fasten it with the supplied strap (1)
- prepare the slats (2) inserting the locking plugs (3) in the corners of each one of them, as shown in the figure below

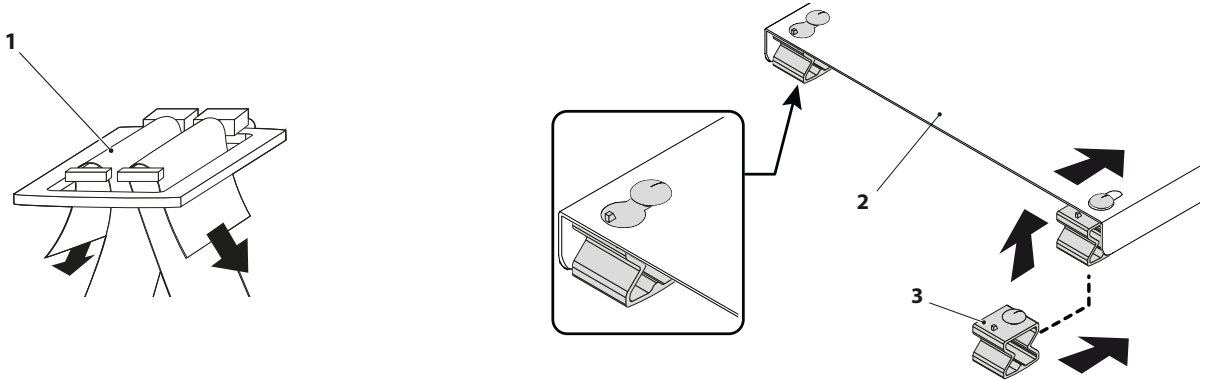

- fasten the uprights and the crosspieces (4) to the plates (5) with the screws and nuts supplied as standard



IMPORTANT

the crosspiece (6), if included in the package, must be positioned between the two square pipes to support the slats.

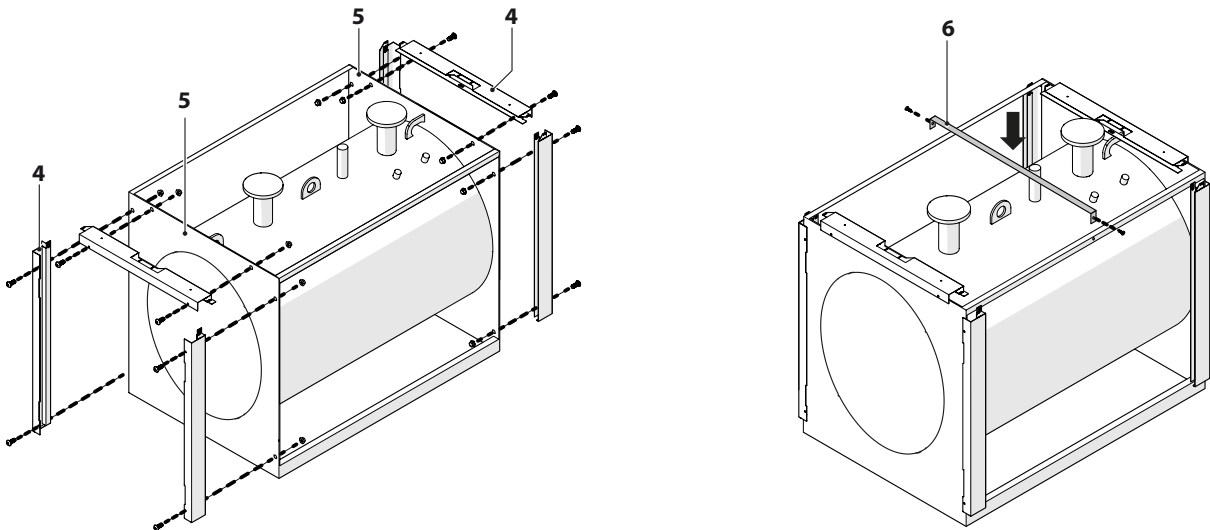

- insert the slats (2), previously prepared with locking plugs, between the uprights and the crosspieces, as in the figure. Leave the upper corner uncovered on the pockets side for the following installation of the control panel with the relevant bulbs
- after completing the installation of the slats and the fastening of the central templates (7), fasten the closing profile (8) with the self-tapping screws supplied as standard

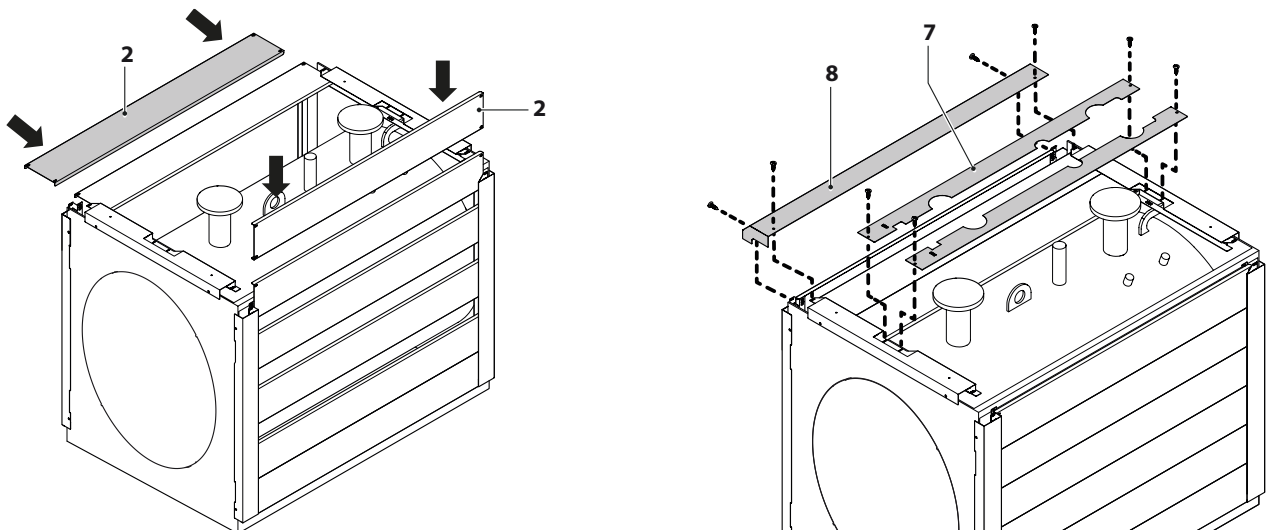

POSITIONING THE CONTROL PANEL

NOTE

The image of the control panel is only indicative as it may vary depending on the chosen model.

Proceed as follows to position the control panel:

- Fit the relevant support (9) of the control panel present in the kit on the front crosspiece of the boiler
- Position the control panel (10) on the support (9) and route the boiler regulation thermostat, safety, pump enabling and boiler thermometer wires through the opening provided until reaching the bulb holder pockets (11) on the tube bundle.
- Fasten the control panel to the support with the supplied screws
- Complete the installation of the slats and closing profile (8) with the self-tapping screws supplied as standard.

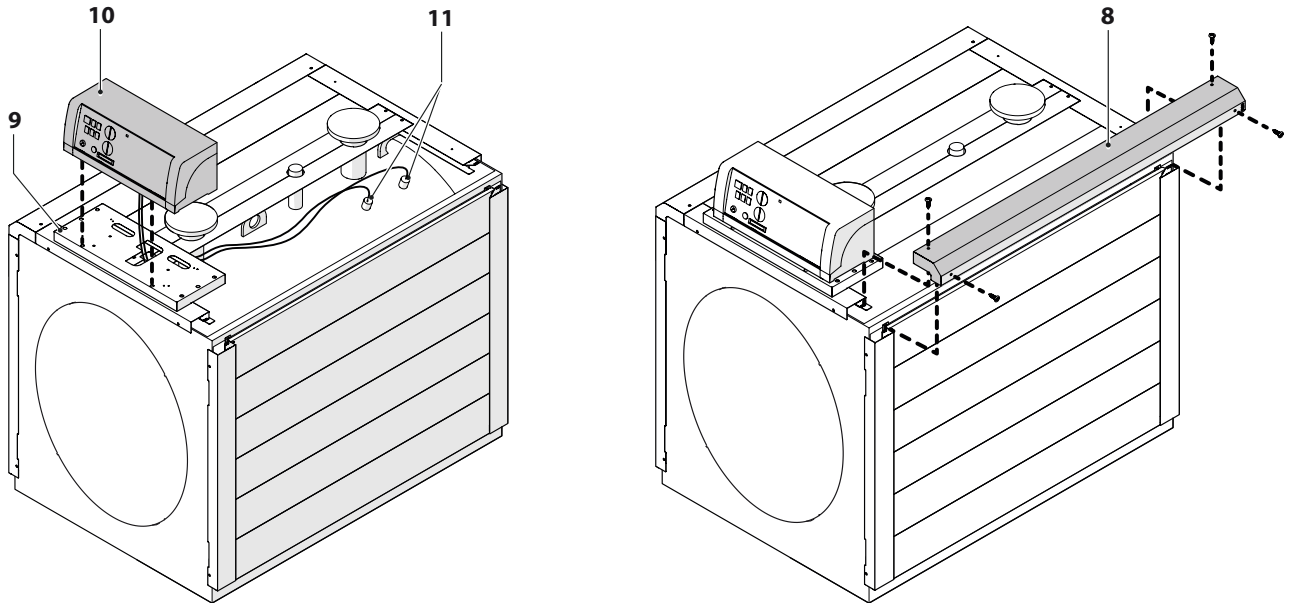

BULB FASTENING

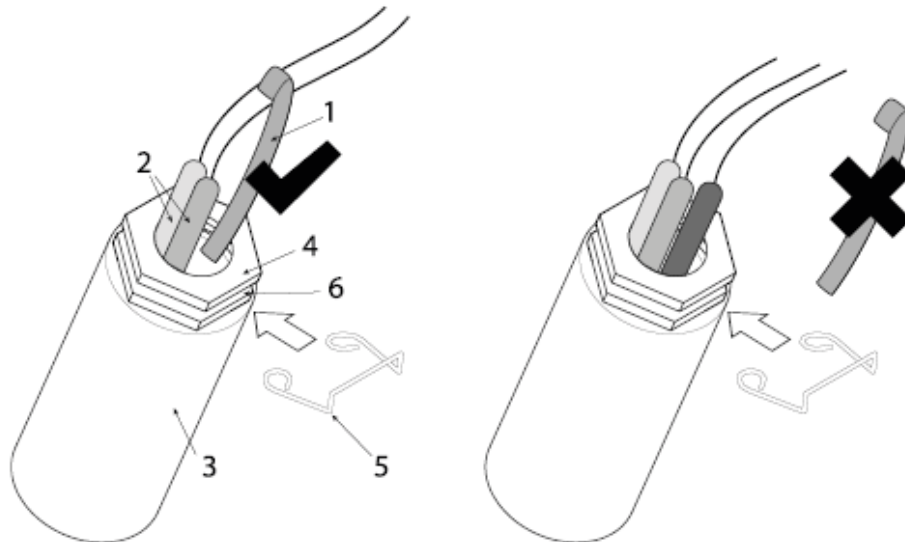

To achieve good thermal contact, it is necessary to use the retainer (1) to push the copper bulb (2) inside the pocket (3) screwed in the sleeve (4).

Insert the clip (5) into the groove of sleeve (6) to avoid that the bulb slips out.

Each boiler is equipped with 2 retainers and 2 clips.

If a sleeve features 3 bulbs, the retainer is not required.

BURNER ASSEMBLY

Having chosen the burner to be used, refer to the Manual supplied with it for information about:

- the installation and fastening to the boiler
- the connection to the fuel supply
- the electrical connections
- the adjustments to be made
- maintenance
- the necessary checks.



IMPORTANT

The strip of ceramic insulation supplied with the generator must be wrapped all around the mouthpiece at least once to protect the burner flange from the irradiation of the flame. It is not necessary for the ceramic insulation to fill the gap up to the internal surface of the door insulation. If the supplied material is not suitable for the used burner, use other material having characteristics suitable to withstand 1000°C and dimensions suitable to completely close the gap.

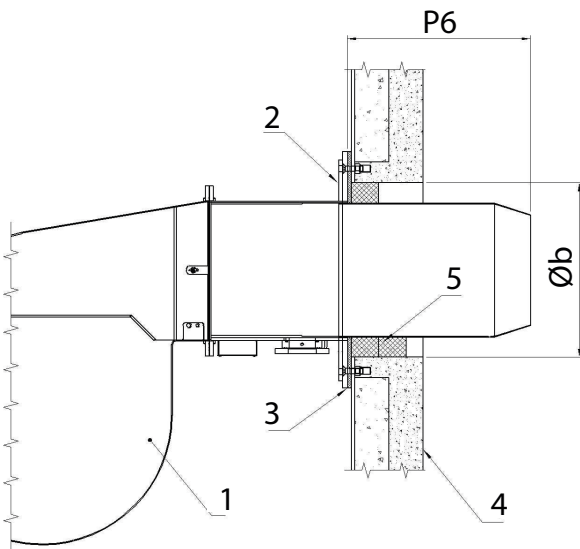

- 1 Burner
- 2 Flange
- 3 Gasket
- 4 Door
- 5 Thermoceramic material



IMPORTANT

For fuel oil/biogas operation, the door should have concrete insulation and be equipped with suitable tie-rods. Any changes and/or failure to disclose information during sales will void the warranty conditions.

ELECTRICAL CONNECTIONS

The electric system of a heating plant room used only to heat the buildings must be made by an authorised company that must comply with regulations, some of which are general while others are specific for the single types of use or combustion.



IMPORTANT

Connect the earth cable to an effective earthing system. **ICI CALDAIE S.p.A.** is not liable for any damage caused by the lack of the earthing system and the failure to comply with the instructions of the wiring diagrams.



PROHIBITION

Do not use the water and heating system pipes for the **earthing connections**.

WATER TREATMENT

The thermal system water must comply with the Laws in force, therefore it is good practise to use treatment units when the line water is particularly rich in calcium carbonate, which causes scale build-ups and corrosion. The table includes some indicative values:

Characteristics	Scale	Filling water	Circuit water
pH*		-	7-8
Hardness (CaCo ₂)	°Fr	< 15	-
Iron (Fe)**	mg/kg	-	< 0.5
Copper (Cu)**	mg/kg	-	< 0.1
Oxygen (O ₂)	mg/l	< 0.05***	-
Appearance		Clear	Possibly clear

* 8 is the maximum acceptable pH value in case of radiators in aluminium or light alloys.

** Higher values indicate on-going corrosion phenomena.

*** In case of agents which form oxygen film and/or surplus, do not observe this value with intermittent operation or operation without deaerator, but use the additive.

LIMESTONE BUILD-UPS

Limestone build-ups reduce the heat exchange between the combustion gases and water, leading to an abnormal increase of temperature of the parts exposed to the flame and thus to a significant reduction of the service life of the boiler.

Limestone gathers in the points where the wall temperature is higher and the best defence against it, at the construction level, is to eliminate the superheating areas.

Scale build-ups form an insulating layer which decreases the heat exchange of the boiler, penalising its efficiency. This means that a significant part of the heat obtained from the combustion is not fully transferred to the system water, but is lost through the chimney.

LIMESTONE DIAGRAM

Lost heat

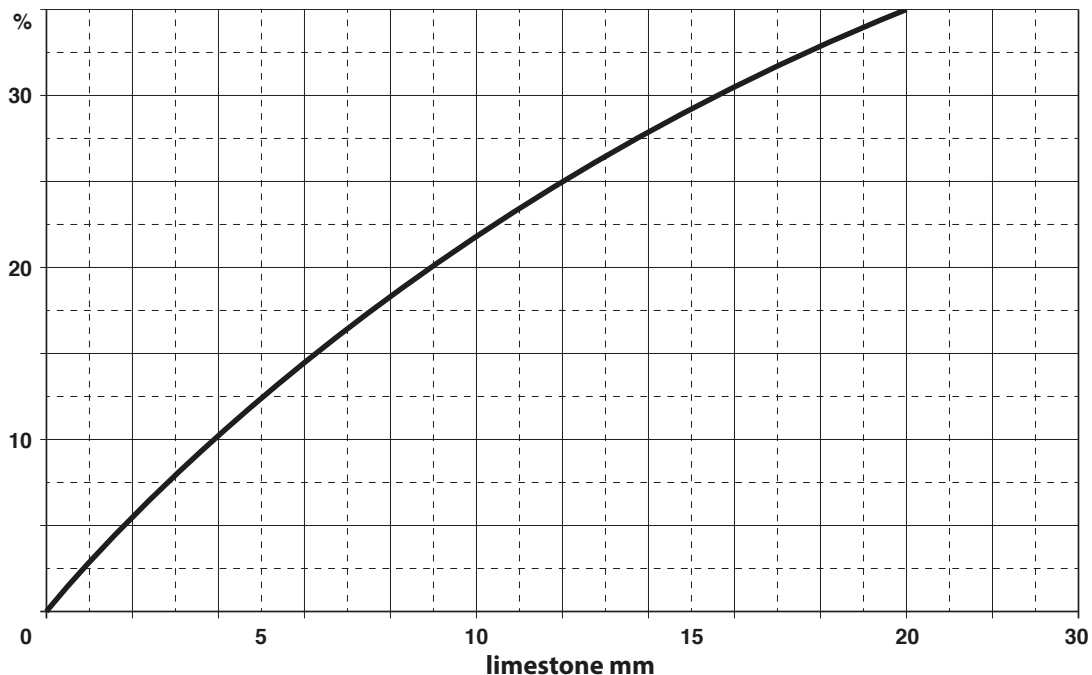

CORROSION ON WATER SIDE

The corrosion of the metal surfaces of the boiler on the water side is due to the iron transit into the solution through its ions (Fe⁺). In this process, the presence of dissolved gases, in particular oxygen and carbon dioxide, is very important. Corrosion phenomena often occur with softened and/or demineralised water, which by nature is more aggressive against iron (acid water with Ph < 7); in these cases, even when scale build-ups are prevented, corrossions can occur and it is necessary to treat the water with corrosive process inhibitors.

SYSTEM FILLING AND EMPTYING

FILLING

- Before filling the system, disconnect the power supply by positioning the system main switch to “**OFF**” and check that the drain valve of the boiler is closed
- open the filling valve of the boiler and the shut-off valve of the water system and allow the water to enter slowly, in quantities proportional to the venting capacity of the automatic or manual air separators, and until the expansion vessel pre-filling static pressure value can be read on the manometer
- close the previously opened boiler filling valve and the water system filling valve
- heat the water for the first time until reaching the system maximum permitted temperature. During this operation, the air contained in the water is vented through the system’s automatic or manual air separators
- once the air has been expelled, bring the pressure back to the preset value and close the manual and/or automatic supply tap.
- After the initial filling, it is necessary to prevent oxygen and untreated water from entering the system.
- The entry of oxygen causes corrosion, while untreated water causes the formation of limestone.
- Both conditions must be avoided.

NOTE

The system venting will be completed, if necessary, upon the first commissioning of the boiler.

EMPTYING

- Before starting to empty the system, disconnect the power supply by positioning the system main switch to “**OFF**”
- check that the hydraulic system shut-off valve is closed
- connect a rubber hose to the drain valve of the boiler and convey it towards a drain pocket
- close the shut-off devices of the thermal system parts which must not be emptied
- slowly open the boiler drain valve. To facilitate the draining, open the air separators on the system
- once the operation is complete, close the previously opened air separators and the drain valve.

3 Use

PRELIMINARY CHECKS

Before commissioning the boiler and carrying out the functional tests, check that:

- the turbulators are installed
- the system has been filled and the hydraulic circuit pressure, in a cold state, is correct
- the flue gases are correctly discharged and there are correctly dimensioned vents
- electrical connections and earth connection are correctly carried out
- the rotors of the circulation pumps are not blocked
- the fuel supply line has been correctly built and that the fuel is available
- hydraulic and fuel circuit taps are open.

COMMISSIONING

To start the boiler after performing the preliminary checks it is necessary to:

- set the regulation thermostat on the control panel to the desired temperature
- check that the release button of the safety thermostat inside the control panel is reset
- correctly adjust the control panel devices according to the installed model
- set the main switch of the control panel to "**ON**"
- the rotors of the circulation pumps are not blocked
- the fuel supply line has been correctly built and that the fuel is available
- hydraulic and fuel circuit taps are open
- check for voltage presence at the control panel and burner.

The boiler will perform the ignition phase and will operate until the set temperatures will be reached.



IMPORTANT

In case of **LOCK-OUT STOP** of the burner, refer to its technical manual.

CHECKS AFTER COMMISSIONING

Once the start-up has been performed, check that the appliance stops and then restarts:

- by modifying the boiler thermostat calibration
- by operating on the control panel main switch
- by operating on the ambient thermostat or chronothermostat
- check the tightness of the door gasket and repeat the adjustment in case of leakages
- check the correct operation of pumps
- check the boiler stop by positioning the system main switch to "**OFF**"
- check the safety thermostat triggering.

If all the conditions are met, start the boiler, bring it to its full operation and collect the combustion data.

NOTE

The flame inspection window is equipped with a hose connector which can be used both as a pressure test connection and for cooling the flame inspection window.

Combustion guide values:

FUEL	%CO ₂	Flue gas temperature	% CO
Gas	10	190°C	0 – 20 ppm
Diesel fuel	13	195°C	10 – 80 ppm
Nafta	13,5	200°C	50 – 150 ppm

A diagram determines the boiler efficiency according to the flue gas and air temperature and the carbon dioxide percentage (%CO₂), but without considering the losses through the boiler casing.

Efficiency diagram (significant losses only) (%)

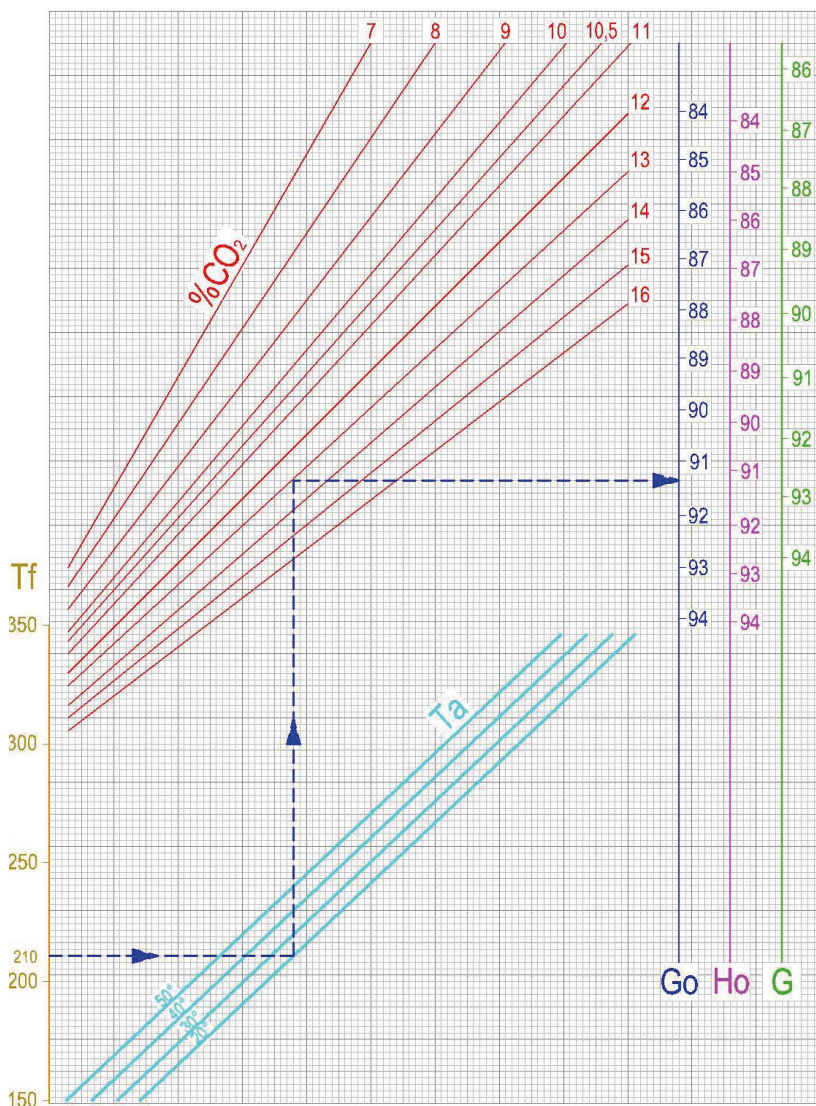

Tf Flue gas temperature in chimney °C
Ta Ambient temperature in °C
G Gas
Go Diesel fuel
Ho Nafta

Example

Flue gas temperature: 210 °C
 Ambient temperature: 20 °C
 %CO₂ 13%
 Fuel: Diesel fuel
Efficiency: 91.4%

The pressurisation must fall within the values indicated in the table of the technical data.

STOP PERIODS

SHORT PERIODS OF TIME

In case of system switch-off for a short period of time:

- position the central panel switches and the control panel switch to “**OFF**”



IMPORTANT

If the external temperature is below ZERO:

- the boiler must be electrically powered
- the fuel supply must be opened
- the boiler thermostat must be adjusted to the minimum value
- the ambient thermostat or chronothermostat must be activated and adjusted to about 10°C or switched to the **anti-freeze** mode.

LONG PERIODS OF TIME

If the boiler is not used for a long time, it is recommended to:

- position the central panel switches and the control panel switch to “**OFF**”
- close the fuel and water interception valves of the hydraulic system.



IMPORTANT

If the external temperature is below ZERO:

- empty the heating system if there is the risk of frost
- use anti-freeze liquid (propylene glycol) until a maximum percentage of 3%.

DECOMMISSIONING OF OLD APPLIANCES

Decommissioned appliances contain materials which can be recycled and their constructive elements can be easily separated. In this way, the different components can be sorted out for recycling or disposal.

It is required to carefully dispose of dangerous waste in compliance with the laws in force in the country of destination of the appliance.

4 Maintenance

Periodic maintenance is prescribed by Law and must be performed only by qualified personnel, at least once a year or more frequently, depending on the boiler output and on the fuel used.

The boiler maintenance and cleaning operations are essential for its safety and to keep its efficiency high, extending its service life.



IMPORTANT

Before performing any maintenance or cleaning:

- disconnect the power supply by positioning the system main switch and that of the burner, if any, to “OFF”
- close the fuel supply
- use all Personal Protective Equipment required by current Standards and Legislation
- wait for the boiler and the system to cool down.

BOILER

External cleaning

To perform the external cleaning of the boiler (cover) use cloths moistened with water mixed with denatured alcohol or specific non-abrasive detergents. Dry the surfaces thoroughly after cleaning.

Internal cleaning

To perform the internal cleaning:

- disconnect from the burner anything which may hinder the door opening
- loosen the ring nuts with handle (1), open the door (2) and extract the turbulators (3)

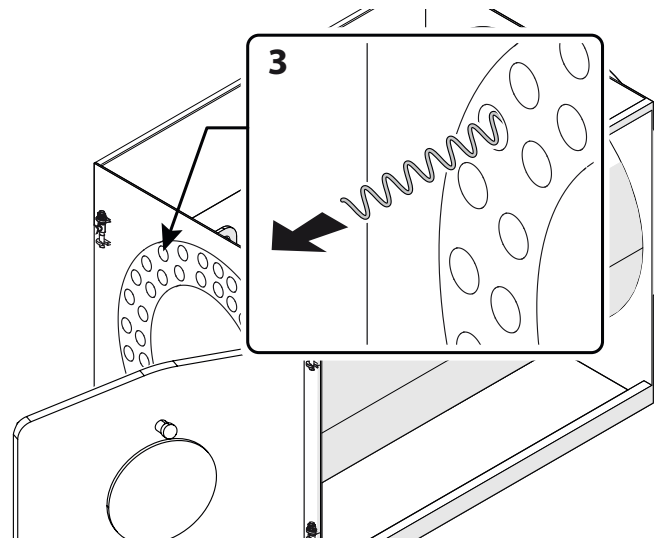
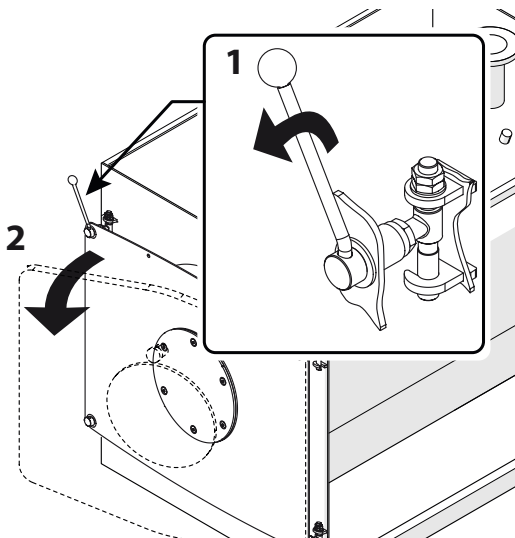

- remove the inspection door of the smokebox
- clean the surfaces of tube bundle and combustion chamber with a brush (4) and/or other suitable tools
- suck, through the smokebox cleaning door, any deposit build-up.

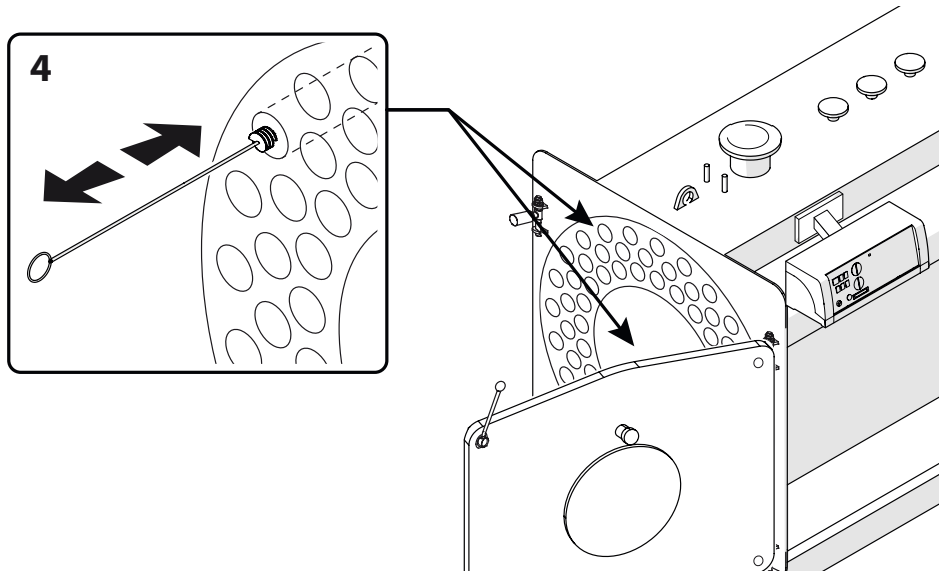

If necessary, remove the smokebox and replace the gasket before refitting it.

Once the cleaning operation is completed, reassemble all the components, replacing those worn out and operating by following the previous procedure in the reverse order.

BURNER

For burner maintenance and cleaning follow the instructions on the burner manual or any other indication provided by the burner manufacturer.

ANY ANOMALIES AND REMEDIES

ANOMALY	CAUSE	REMEDY
The boiler gets dirty easily	Badly adjusted burner	Check the burner adjustment (flue gas analysis)
	Clogged chimney	Clean the flue gas path and the chimney
	Dirt burner air path	Clean burner air coil
The boiler does not reach the correct temperature	Dirt boiler body	Clean the flue gas path
	Wrong boiler/burner match	Compare burner data with tabulated matches
	Insufficient power to the burner	Check the burner adjustment
	Wrong adjustment	Check the correct operation
The boiler switches to thermal safety lock-out	Wrong adjustment	Check the set temperature
		Check the correct operation
		Check the electrical wiring
		Check the probe bulbs
	Lack of water	Check the circuit pressure
	Air presence	Check the vent valve
The boiler is at the correct temperature but the heating system is cold	Presence of air in the system	Vent the system
	Faulty circulation pump	Unlock the circulation pump
	Minimum Thermostat wrong adjustment (if any)	Check the set temperature
	Faulty minimum Thermostat (if any)	Check the efficiency
Unburned material odour	Flue gases dispersion into the environment	Check the boiler body cleanliness
		Check the flue gas pipe cleanliness
		Check the tightness of boiler, flue gas pipe and chimney
		Check the door tightness
Gas smell	Gas supply circuit	Check sealing, possible obstructions, combustion quality
Frequent safety valve triggering	Excessive pressure in the system circuit	Check load pressure
		Check pressure regulator
	Malfunction of the system expansion vessel	Check calibration
		Check the efficiency

ENVIRONMENTAL PROTECTION AND DISPOSAL

Protection and respect for the environment is a fundamental principle for **ICI CALDAIE S.p.A.**

The quality of products, lower costs and protection of the environment are of equal importance for the company. **ICI CALDAIE S.p.A.**, also through ISO 14001 certification, strictly adheres to European laws and standards for the protection and preservation of the environment.

In order to reduce its impact on the environment, the company uses the best technology and materials in its production processes and always considers their economic impact.

Thermal insulators are special waste and must therefore be disposed of in compliance with the applicable legislation.

EXPLODED VIEWS OF DRAWINGS

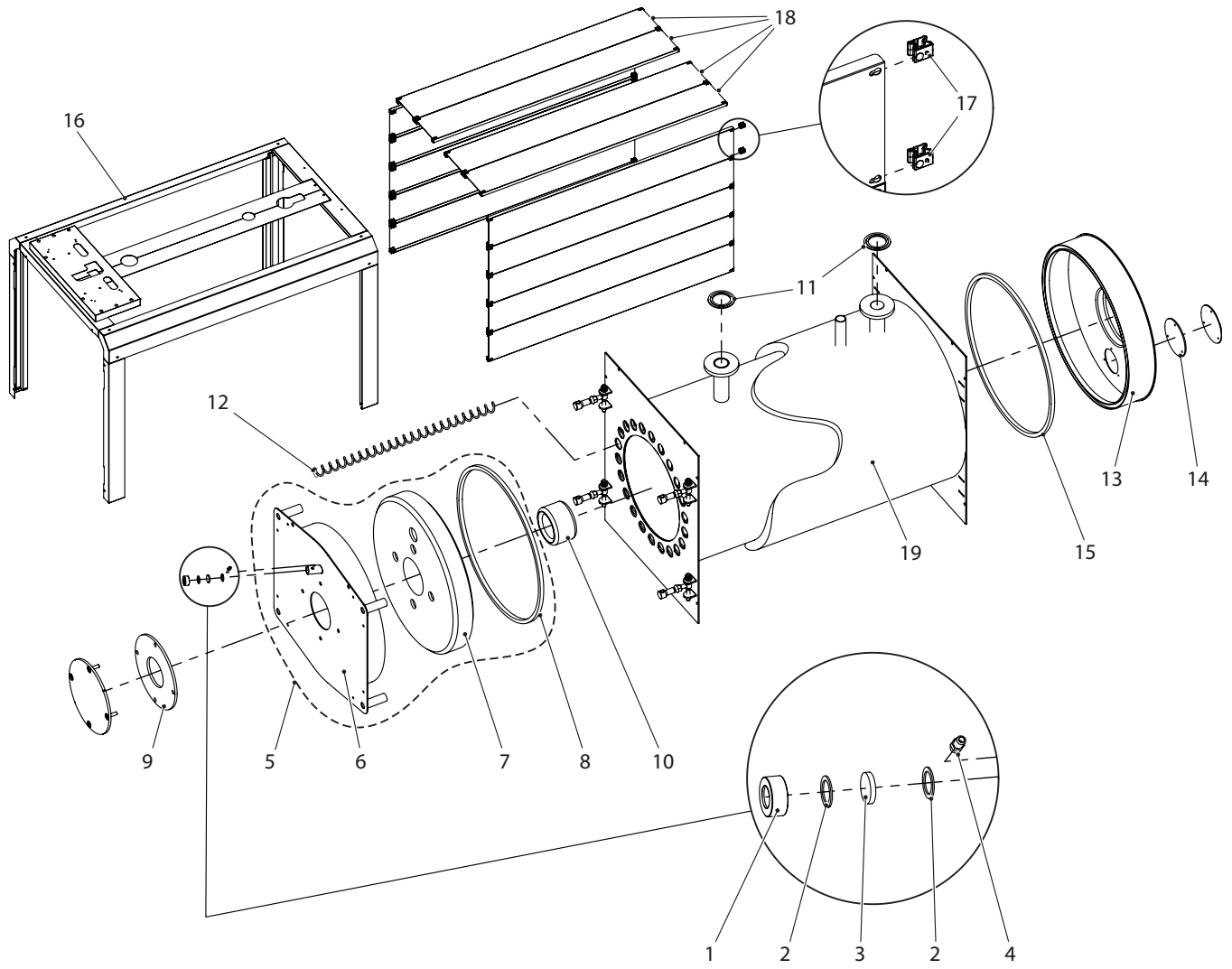

- | | |
|--|---|
| <ul style="list-style-type: none"> 1 Ring nut for flame inspection window 2 Flame inspection window gasket 3 Flame inspection window glass 4 Pressure test point on flame inspection window 5 Complete door 6 Door 7 Door internal insulation 8 Door fibreglass braid 9 Isolcart insulating panels between burner and door 10 Burner nosepiece mat kit | <ul style="list-style-type: none"> 11 Flow and return gaskets 12 Turbulators 13 Smokebox 14 Isolcart insulating panels for smokebox cleaning door 15 Smokebox fibreglass braid 16 Slat covering frame kit 17 Slat locking plugs 18 Slats 19 Tube bundle insulation (fibreglass wool) |
|--|---|

5 Useful information and declarations

QR CODE

How to register your appliance



The appliance must be registered once the product has been installed, either before or after start-up.

Follow these steps:

- Obtain a smartphone (iPhone, Samsung Galaxy, Htc, Blackberry etc.) or a tablet
- after downloading and installing a "QR Reader" application (any free application is usually more than enough), open it and point the camera on the QR code located on the plate of your appliance (circled in the image)
- you will be sent back to a web page on which to register the data of your appliance and system by completing the indicated spaces.

R107			
ICI CALDAIE S.p.A. Via G.Pascoli, 38 - 37059 ZEVIÒ (VR) - ITALIA -			
<i>Tipo - Type - Typ - Modelos</i>		<i>Matricola - S/N - Matricule - Matricula</i>	
<i>Codice - Code - Code - Codice</i>			
CALDAIA PER RISCALDAMENTO - HEATING BOILER CHAUDIERE CHAUFFAGE - CALDERAPOR RISCALDAMIENTO			
PORTATA TERMICA - HEAT INPUT DEBIT THERM. - POTENC. TERM.		POTENZA UTILE - HEAT OUTPUT DEBIT THERM. UTILE - POTENCIA UTIL	
Q		P	
MAX	4333 kW 3.726.380 Kcal/h	MAX	4000 kW 3.440.000 Kcal/h
RISCALD. - HEATING - CHAUFFAGE - CALEFAC.		SANIT. - SAN.WATER - EAU SAN. - AGUA SAN.	
TEMP. T	110 °C	TEMP.	°C
PRES. PMS	6 BAR	PRES. PROD.	BAR
		dT	°C
COMBUST. LIQUIDO - LIQUID FUEL		GAS CATEG. V. CATEG. BRUC.	
GASOLIO - LIGHT OIL METANO - METHANE		TIPO - TYPE - TYP B23 GAS G20 (METANO-METHANE) 20 MBAR GAS G30-G31 (GPL-LPG) 28-30-37MBAR	
BRUCIAT. - BURNER - BRULEUR - QUEMADOR		V. 1/N- 230 ~	
ALIM.ELETT.-VOLTAGE-ALIM.ELECT.-TENSION D'ALIMENT.		Hz. 50	
		W. 20	
CLASSE PROT.-PROTECT.CLAS- CLASE DE PROC.-PROTEC.		IP40	
CLASSE NOx - NOx CLASS -			

Once registered, authenticate your e-mail address by clicking on the link that will be sent by e-mail to the provided inbox. An additional e-mail will then be received with the credentials to access all services specifically developed by **ICI CALDAIE S.p.A.** for those who will register their boiler through the QR Code. Registration entitles you, even in future months and years, to take advantage of promotions and specific services for registered appliances (e.g.: discounts on spare parts, spare parts kits on sale, free routine maintenance for certain types of products, etc.).

For information, contact the ICI headquarter or the local representative offices.
www.icaldaie.com - info@icaldaie.com

DECLARATION OF CONFORMITY



ICI CALDAIE S.p.A.

Via G. Pascoli, 38 – Frazione Campagnola
37059 Zevio (VR)

Telephone +39 045 8738511-Fax +39 045 8731148

info@icaldaie.com – VAT number IT 00227490232

Company subject to management and coordination by FINLUC s.r.l.

(R.I. n. 02245640236)

Company certified according to ISO 9001, OHSAS 18001 & ISO 14001

icaldaie.com

DECLARATION OF CONFORMITY WITH EUROPEAN COMMUNITY STANDARDS

The undersigned Emanuela Lucchini, CEO of ICI CALDAIE S.p.A., with registered office in Via G. Pascoli, 38 - 37059 Campagnola di Zevio (VR), Italy.

Declares that the boilers:

REX/REX F
REX K/REX K F
REX DUAL/REX DUAL F

conform to the type described in the EC certification and comply with the following Council Directives:

- European Regulation on Gas Equipment GAR 2016/426/EU
- Electromagnetic Compatibility Directive 2014/30/EU
- Low Voltage Directive 2014/35/EU
- Efficiency Directive 92/42/EEC

Zevio, 07/05/2018

ICI CALDAIE S.p.A.
Direttore Generale
Emanuela Lucchini

A handwritten signature in black ink, appearing to be 'Emanuela Lucchini', written over the printed name.

6 Notes



ICI CALDAIE SpA

37059 Fraz. Campagnola di Zevio (Verona) Italy

Via G. Pascoli 38 Phone: +39 0458738511 Fax:+39 0458731148

info@icicaldaie.com www.icicaldaie.com