



GREENOx.e



DESCRIPTION







Three pass, wet back, low thermal load boiler, with single pass flame furnace, connected to forced draft burners with operation on liquid or gaseous fuels. The boiler is designed to be used in systems with water temperature between 60 and 100°C (safety thermostat set at 110°C).

FEATURES

-  **Design pressure: 5 bar**
-  **Heat output: 420 ÷ 3000 kW**
-  **Efficiency: > 95,0 %**

For higher or lower pressures see our commercial department

ADVANTAGES

-  **High efficiency and large exchange surfaces**
Extremely high energy efficiency thanks to the large exchange surfaces allowing top efficiency values under all operating conditions.
-  **Low thermal load**
NOx emissions in compliance with the most stringent standards thanks to the extremely low volumetric thermal load designed to obtain the best coupling with low emission burners.
-  **Easy, fast and safe installation**
The installation is very easy: you just need to connect the system to the electric, hydraulic, steam and discharge lines.
-  **Maximum security**
The generator has been designed in accordance with the strictest international safety regulations in force.
-  **High reliability in continuous operation**
The construction features are such to make it particularly suitable to high working loads and long working periods.
-  **Maximum operating flexibility**
Thanks to the very high water content and the very high thermal inertia, the boiler is suitable for any system solution, even in the most difficult operating conditions.

Three pass, low NOx emission boiler

MODELS



GREENOx.e (420 ÷ 700 kW)



GREENOx.e (800 ÷ 3000 kW)

AVAILABLE CERTIFICATIONS



RECOMMENDED TECHNOLOGIES



MAIN APPLICATIONS

- + Commercial facilities
- + Hospitals
- + District heating
- + Heavy industry
- + Residential buildings
- + Industrial heating systems
- + Sports centers
- + Swimming pools and water parks

DIMENSIONS

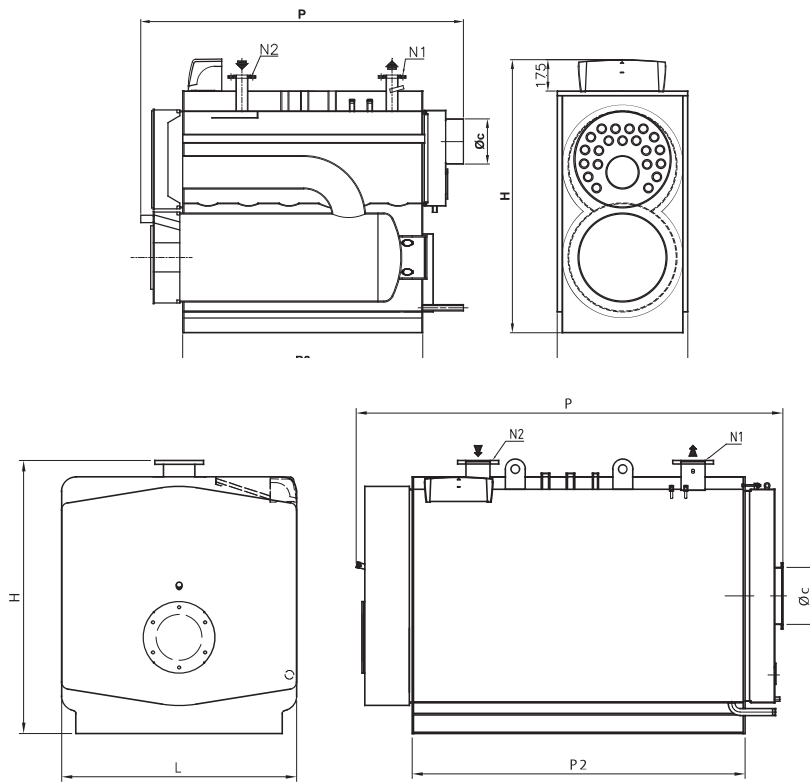

Model	H	L	P	P2	Øc	N1	N2
GREENOX	mm	mm	mm	mm	mm	DN/in	DN/in
40	1675	800	1948	1462	250	80	80
47	1805	875	2227	1744	250	80	80
60	1925	945	2228	1746	250	100	100
70	1925	945	2228	1746	250	100	100
80	1775	1380	2535	1970	350	100	100
90	1775	1380	2535	1970	350	100	100
100	1825	1490	2589	1972	400	125	125
120	1825	1490	2589	1972	400	125	125
140	1825	1490	2899	2282	400	150	150
170	2125	1800	2966	2324	400	150	150
200	2125	1800	3466	2824	400	150	150
230	2125	1800	3466	2824	400	150	150
260	2125	1800	3935	3324	500	200	200
300	2125	1800	3935	3324	500	200	200

TECHNICAL DATA

Model	Heat Output - temp. 70°C	Flow thermal	Flue gas pressure drop	Hydraulic pressure drop	Total volume H2O	Empty weight
GREENOx	kW	kW	mbar	mbar	l	Kg
40	420	441	5,2	42	505	850
47	470	493	4,6	53	738	1110
60	600	630	4,9	35	863	1390
70	700	734	5,6	48	863	1390
80	800	839	2,8	63	1200	1970
90	900	944	3,5	80	1200	1970
100	1000	1050	2,6	40	1365	2760
120	1200	1259	4,0	58	1365	2760
140	1400	1469	5,5	38	1570	2995
170	1700	1784	5,0	56	2300	4300
200	2000	2099	7,0	78	2800	4850
230	2300	2415	9,0	103	2800	4850
260	2600	2731	9,0	42	3300	5950
300	3000	3150	12,0	55	3300	5950

STANDARD EQUIPMENT

- Complete insulation casing
- Turbulators
- Cleaning brush

PRODUCT CODES

Model	Code
GREENOx.e 40	83090350
GREENOx.e 47	83090400
GREENOx.e 60	83090500
GREENOx.e 70	83090600
GREENOx.e 80	83090804
GREENOx.e 90	83090900
GREENOx.e 100	83091004
GREENOx.e 120	83091204
GREENOx.e 140	83091400
GREENOx.e 170	83071700
GREENOx.e 200	83072000
GREENOx.e 230	83072300
GREENOx.e 260	83072600
GREENOx.e 300	83073000

AVAILABLE ACCESSORIES

Code	Description	Model	
		GREENOx.e 40 - 70	GREENOx.e 800 - 3000
QACC10ELMCE	Thermostatic control panel	■	■
QETERM01CE	Eterm boiler management control panel	■	■
QETERM01RU2	Eterm boiler management control panel - only for Russia and the former Soviet Union	■	■
QETERM02	Eterm system control panel	■	■
QCTETERM	Eterm easy manager panel	■	■